

LineMaster™ is for all continuous extrusion processes including film, sheet, pipe, coating and lamination, wire and cable and compounding.

The LineMaster flexible design provides several measurements and control options, and includes an integrated system for combining gain-in-weight dosing control with loss-in-weight extrusion control. The system is an easy to use, low cost alternative to competitive loss-in-weight systems and does not compromise performance and control.

- **Improved Product Quality**
Through permanent and consistent control
- **Reduced Material Costs**
Typical process variations are reduced with LineMaster gravimetric control to within $\pm 0.5\%$, significantly reducing resin consumption
- **Automatic Regulation of Extruder Output**
Control is maintained by monitoring the throughput of the process and regulating the extruder speed
- **Increased Line Productivity**
With fast start-up and reduced production scrap
- **Quick Product Changeover**
With easy-to-clean hoppers and quick response software
- **Alarms and User Security**
Ensures that only authorized personnel can change parameters
- **G2 Software and Ethernet Communications**
Multiple LIW units can be linked via Ethernet communications to the LineMaster Extrusion Control Software for multi-layer applications



Weight Measurement Options



Enhanced Extrusion Control with Loss-in-Weight Hopper

The LineMaster product range monitors material consumption by means of a loss-in-weight hopper mounted on the process throat. The weight consumption data is reported to the LineMaster Control Operator Interface (XCC) which utilizes the information to control either throughput or yield with the feedback from a digital encoder measuring line speed. Multiple LIW units can be linked via Ethernet communications to the LineMaster Extrusion Control Software for multi-layer applications.

XC Control Options

LineMaster is a comprehensive range of products that is designed to serve the vast majority of extrusion operations that require solutions based at every level of the cost / performance spectrum. The available control options provide throughput control for pounds or kilograms per hour, weight per length control for lb/ft or gm/M and gauge control in microns.

XC-1 Throughput Control

Control is maintained by monitoring the throughput of the process and regulating the extruder speed. The XCC controller utilizes the consumption data from the LIW hopper and communicates with the XCD-X Extruder Drive Speed Control to adjust the extruder speed via a 0-10 volt signal to maintain the throughput target.

XC-2 Yield Control

XC-2 offers the ability to maintain a product's weight per length (lb/ft or gm/M) by monitoring the process throughput against the line speed. An XCE Digital Encoder mounted on a take-off device monitors the line speed. Control is accomplished by adjusting either the extruder speed with a XCD-X Drive Speed Control Module by referencing the manually controlled line speed or controlling the take-off speed with a XCD-T Line Speed Control Module from a manually controlled extruder.

XC-3 Multi-Layer Yield Control via Computer

XC-3 provides complete weight per length control (lb/ft or gm/M), via simultaneous control of the extruder and take-off. Controllers are connected via a high speed serial or Ethernet network using the XC Software. Gauge or thickness control can be initiated in set-up utilizing data of the materials or blend specific gravity.

Advanced Weight Control Benefits:

- Lines requiring constant feedback
- Frequent job / material / production changes
- Co-extrusion lines
- Lines requiring frequent ramp up/ramp down control
- Lines using only one material

Loss-In-Weight Hoppers

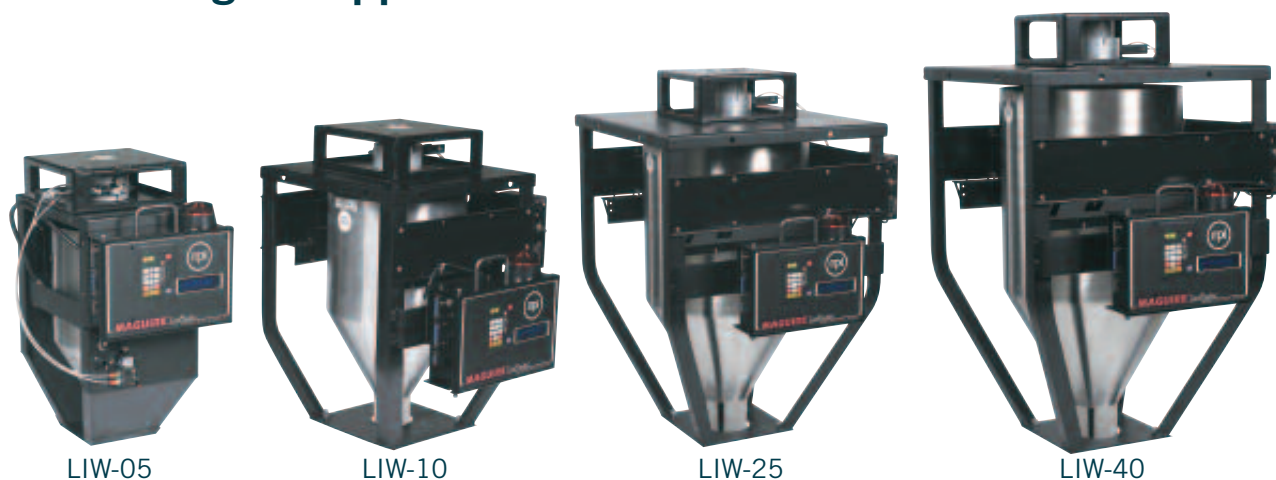

LIW-05

LIW-10

LIW-25

LIW-40

Computer Control and Data Options

With the LineMaster™ the Gravimetric Gateway™ (G2) software program is available for centralized control and data reporting. The software program is an integral part of the XC-3 Extrusion Multi-layer Control and is an option for mono-layer applications of throughput or yield control.

A brief overview of G2

A Gravimetric Gateway™ Server (G2 Server) provides communication with all NOVATEC blender controllers for data collection and control. The G2 software enables communication directly from the server with one or more blenders or loss-in-weight controllers to connect remotely from anywhere over a TCP/IP network using the Gravimetric Gateway™ Client software. The server provides two-way communication with the network of blenders and loss-in-weight controllers for constant retrieval of information such as:

- Precise weight of all materials
- Settings (sending and retrieval)
- Recipe numbers
- Work order numbers
- Operators information

The G2 server organizes and tracks material usage and allows the user to gather accurate information according to a number of factors including: time period (day, shift, etc.), process machine, work order, operator, recipe, blender and line recipe.

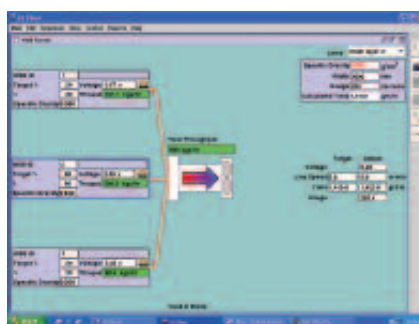

3-Layer Co-Extrusion Overview Screen



Line / Blender Overview Screen

Throughput and Yield Control

LineMaster can monitor and control up to 7 layers; each layer is graphically depicted (see above screen shot). All lines visually merge where the Total Throughput is displayed. take-off and downstream controls are displayed at the right showing line speed, weight per length and/or gauge. A more detailed examination of each blender's settings and output can be accessed through the Line Blender Screen by clicking on the individual extruder.

Throughput Reporting

The software also allows reporting on average throughput, total throughput, and the percentage of total uptime of an individual blender or all blenders in the line. Reports are based on start/stop date and time, weight units and percentage of run time.

Event Monitoring

The computer software also incorporates an event monitoring service allowing users to access a history of alarms, actions and changes.

Materials and Blend Management

The software can also store a complete dataset of materials and recipes used in production. This data is easy to edit and maintain, and allows for full tracking of material consumption and inventory management – a valuable tool for data regarding quality, certification, costs and productivity.

Reduce Resin Consumption With LineMaster™ Gravimetric Extrusion Yield Control

The diagram to the right illustrates a 3-layer film line utilizing LineMaster™ Extrusion Control. Loss-in-weight hoppers are mounted on 3 extruders that are feeding the die producing the film bubble. The loss-in-weight hoppers provide precise throughput data and an encoder (mounted on nip rolls or any rotating shaft) provides line speed data. Adjustments are made for any change in throughput

due to screen pack, back pressure, melt temperature or other variables detected. Typical process variations are reduced with LineMaster gravimetric control to within $\pm 0.5\%$, significantly reducing resin consumption. Typically, 3 to 4% resin savings is realized resulting in payback in as little as 6 months. LineMaster simplifies line start-up, enables rapid job changes and reduces scrap during string-up.

Applications

Film and Sheet

(see illustration to the right)



Wood Composite



Corrugated



Pipe & Tubing



Wire & Cable



Extruder Drive
Speed Control
Model XCD-X

take-off / Line
Speed Control
Model XCD-T

LineMaster™ Speed Control modules communicate directly with the XCC controllers. The controller receives process throughput updates from the loss-in-weight hopper and commands the speed control modules to increase or decrease screw rpm. The speed control modules provide either a 0 – 10 Vdc analog or digital signal to the extruder or take-off drive being controlled. The XCD Speed Control Modules include a digital potentiometer which replaces the existing manual pot or can communicate with an existing digital speed control. A toggle switch is included to provide selection of either Manual or Automatic control.



Optional Surge Hopper

Infeed Butterfly Valve

LineMaster™ Encoder



XCC controller

BLEND

Specifications

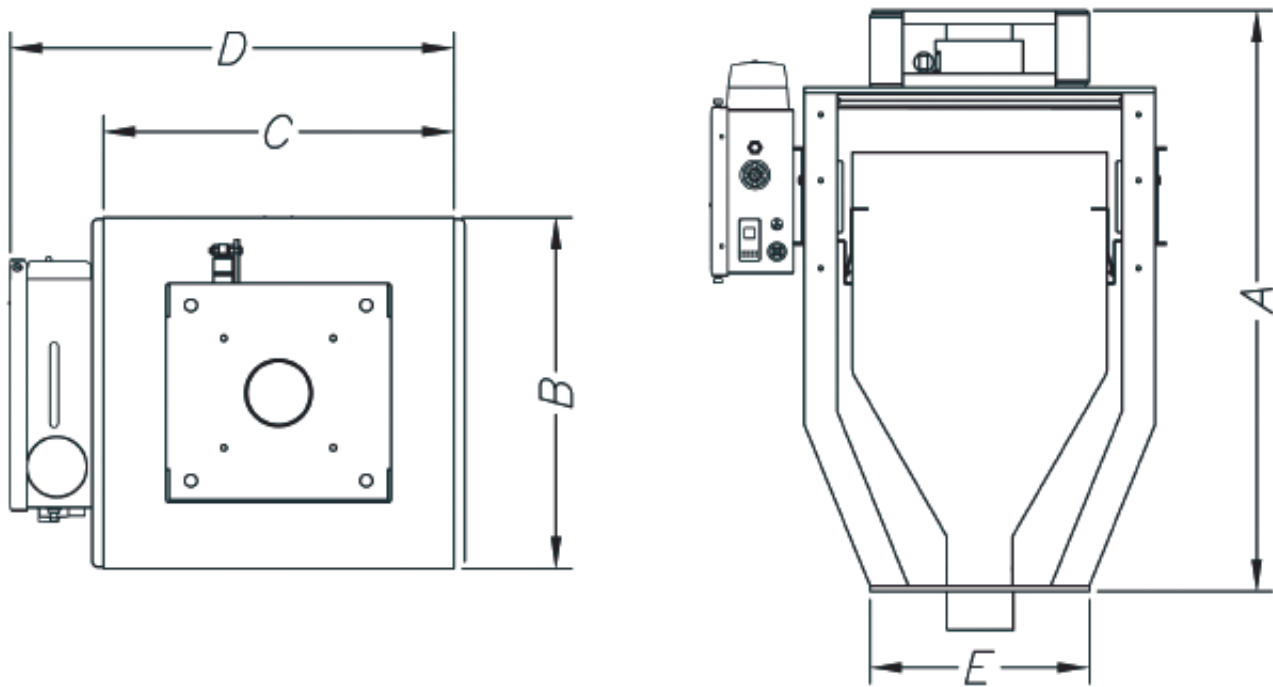

Model	Capacity cu.ft. (liters)	Throughput Range lb/hr (kg/hr)	Dimensions - inches (mm)					Weight lb. (kg)
			A	B	C	D	E	
LIW-05	0.3 (8.5)	5 - 300 (2.2 - 136)	23.5 (596.9)	12.0 (304.8)	14.2 (360.7)	18.2 (462.3)	6.0 x 6.0 (152.4)	56 (25.5)
LIW-10	0.6 (17.0)	100 - 600 (45 - 272)	26.5 (673.1)	16.0 (406.4)	17.7 (449.1)	20.0 (508.0)	10.0 x 10.0 (254.0)	74 (33.6)
LIW-25	1.6 (45.3)	500 - 1,500 (228 - 682)	35.5 (901.7)	17.7 (449.1)	22.0 (558.8)	26.0 (660.4)	10.0 x 10.0 (254.0)	120 (54.6)
LIW-40	2.5 (70.8)	1,000 - 3,000 (454 - 1,364)	42.5 (1,079.5)	23.7 (602.0)	22.0 (558.8)	26.0 (660.4)	10.0 x 10.0 (254.0)	140 (63.6)