

Designed for a wide range of throughput rates to meet the needs of injection molding and extrusion processes.

Choose from a range of auger sizes and variable speed motors, coupled with automatic speed control, to meet your feed rate requirements. The MRF can be mounted directly to the feed throat or below the natural material hopper and above the color concentrate feeder.



MRF-16-50

- **Reduce Color Concentrate Costs**

Use previously colored regrind to minimize use of color concentrate

- **Easy Selection of % Color Regrind**

A “% regrind” rotary switch is provided on the feeder controller for selecting the exact percentage of regrind to be added

- **Automatic Compensation for the % Color Regrind**

Signal output from the regrind feeder is accepted by NOVATEC feeder series MCF & MLG which automatically compensate for the percent of regrind set for the mix so when regrind runs low, the regrind feeder will automatically shut off and full 100% coloring will be resumed

- **Clean Out Chute**

Hopper is emptied rapidly and completely by way of a hinged cleanout chute located directly under the feed screw and hopper

- **Practical Hopper Design**

Removable hopper includes sight glasses for viewing color level – an automatic loader can be easily mounted on the lid

- **Stainless Steel Contact Surfaces**

For all color contact surfaces including the hopper and flow chamber baffles

Plus:

- Baffles assure even distribution of regrind
- Automatic auger rotation control
- Remote control
- 115/1/60Hz operation
- 5 -Year warranty

Specifications

Model	Hopper Size	Auger Size	Motor RPM	Continuous Output Lb.hr. (kg/hr.)	
	Ft. ³ (Liters)		Maximum	Minimum	Maximum
MRF-8-34	0.5 (14)	1" (25mm)	55	.05 (0.02)	58 (26)
MRF-8-50	0.5 (14)	1" (25mm)	100	.1 (0.05)	105 (48)
MRF-16-50	2 (57)	2" (50mm)	100	.7 (0.32)	533 (242)
MRF-16-94	2 (57)	2" (50mm)	188	1.6 (0.73)	1000 (453.5)
MRF-16-160	2 (57)	2" (50mm)	320	8.0 (3.6)	1700 (773)

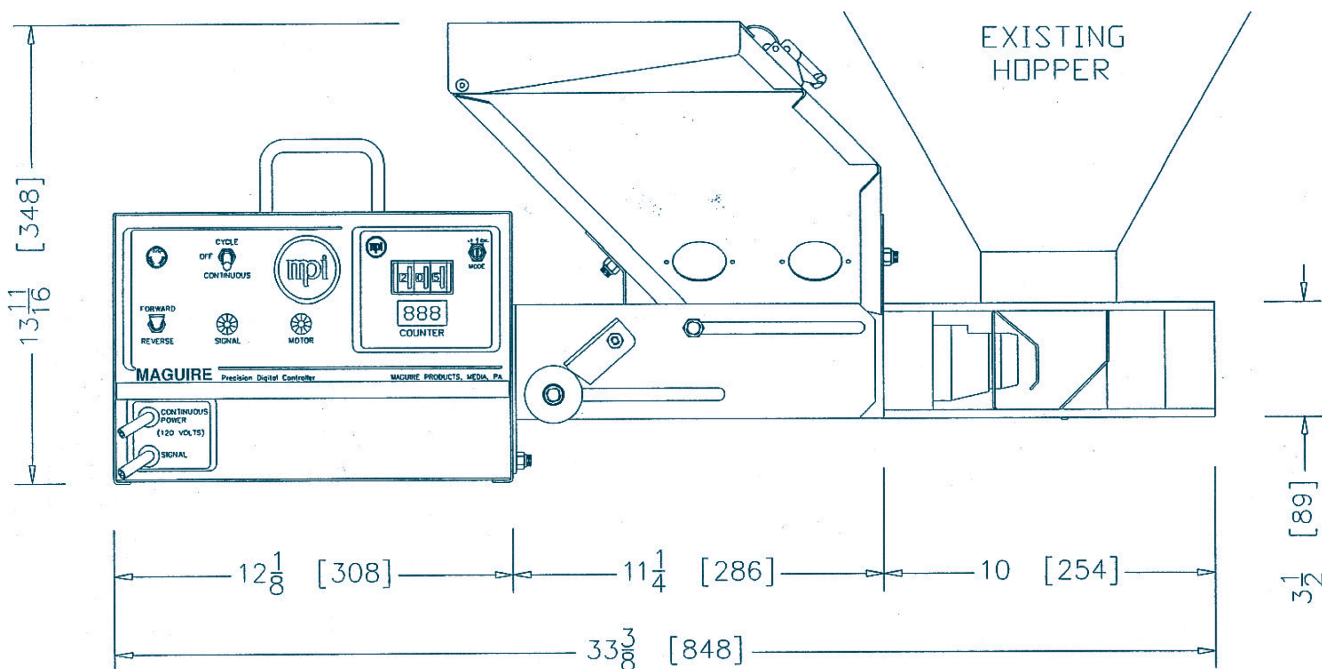

Accessories:

(Show as separate line item on order – shipped separately) See Price List # 229

Hopper Extension:

For MRF-8: 0.5 Ft.3 (14 liters) Part # aseh

For MRF-16: 1.8 Ft.3 (51 liters) Part# as804-E