

Protects the vacuum pump and reduces filter maintenance by collecting up to 99% of dust and fines before they reach the pump.

CDC series, cyclone-style, dust collectors provide highly efficient separation of carry over dust and fines from conveying air. The cyclonic action removes up to 99% of carry over fines that are drawn towards, and can damage, the central pump in a vacuum conveying system. The CDC is free standing and may be located anywhere between the pump filter and the conveying system.

These fines can be easily emptied from a sealed dust collection pan under the CDC.

- **Rugged Construction**

Heavy gauge steel construction, robust angle frame with floor mounting tabs and welded tube stubs.

- **Two Configurations Available**

Standard air-tight collection pan with sight glass or a drum dump model on an elevated frame with a dump valve and discharge sock is available for collecting large quantities of dust and fines in a drum.

- **NEW – Extra Easy Access**

Simple clamp-on collection pan with cradle support allows easy removal and re-assembly when emptying fines.

Gasketed collection pan can be easily slid into groove and clamped in place.

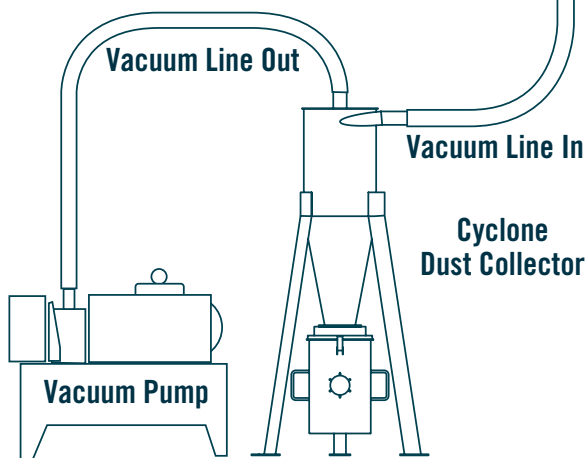

Plus:

- No moving parts and nothing to clean or service
- Optional CF series Cartridge Filter Kit
- 2 Year Warranty

Specifications

(Collection pan on discharge)

Part Number	CDC-15		CDC-20		CDC-25		CDC-30		CDC-40	
Characteristics	U.S.	Metric	U.S.	Metric	U.S.	Metric	U.S.	Metric	U.S.	Metric
Pump power	3hp	2.25kw	5hp	3.7kw	6.2hp	4.6kw	15hp	11.2kw	25hp	18.6kw
Inlet O.D.	1.5"	3.8 cm	2"	5.1 cm	2.5"	6.35 cm	3"	7.6 cm	4"	10.2 cm
Air Volume	55 cfm	93 m ³ /hr	100 cfm	170 m ³ /hr	160 cfm	272 m ³ /hr	240 cfm	408 m ³ /hr	440 cfm	740 m ³ /hr
Height	58"	147cm	58"	147cm	62"	158cm	62"	158cm	79"	201cm
Base diameter	27"	69 cm	27"	69 cm	32"	81 cm	32"	81 cm	41"	104 cm
Shipping Wgt.	165 lb.	75kg	170 lb.	77kg	190 lb.	86kg	210 lb.	95kg	240 lb.	109kg

Dimensions – Drum Dump Package

(Elevated frame, dump valve and discharge sock that will fit the top of a 30 gallon customer supplied drum or for use with 55 gal. drum CCD-55 below. Other specifications same as above.)

Part Number	CDC-15D		CDC-20D		CDC-25D		CDC-30D		CDC-40D	
Height	92"	234cm	92"	234cm	95"	241cm	95"	241cm	109"	277cm
Base L x W	36"	92cm	36"	92cm	36"	92cm	36"	92cm	36"	92cm
Shipping Wgt.	300 lb.	136kg	305 lb.	137kg	440 lb.	200kg	450 lb.	205kg	550 lb.	250kg

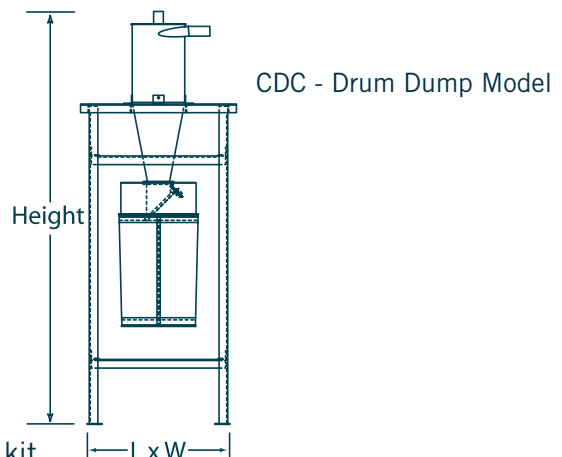
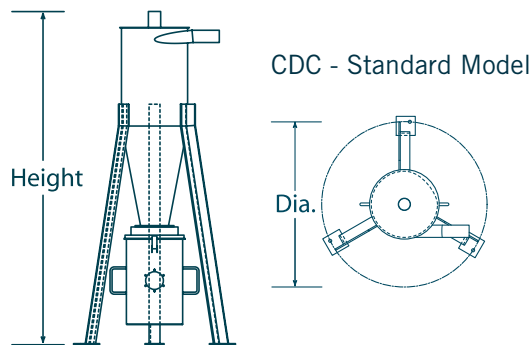

Accessories:

(Separate line item on order and shipped separately - see price list #330)

Cartridge Filter Kit: including Donaldson filter module and hose kit to be customer installed between pump and cyclone dust collector.

Part Number	CFK-15		CFK-20		CFK-25		CFK-30		CFK-40	
Characteristics	U.S.	Metric	U.S.	Metric	U.S.	Metric	U.S.	Metric	U.S.	Metric
Line size	1.5"	3.8cm	2"	5.1cm	2.5"	6.35cm	3"	7.6cm	4"	10.2cm

Cyclone Collection Drum – 55 gallon; Part # CDC-55

Custom Models

Note that all custom features will be priced accordingly and lead times will be extended beyond those of standard packages and accessories.

- Level alarm on collection pan
- Evacuation port on collection pan
- Wall mount for cyclone
- Larger sizes

Accepting MasterCard, VISA and American Express