

Unique, swing-out hopper is perfect compliment for GlassVu™ Loaders and GlassVu™ Receivers.

The JIT Glass Machine Hopper combined with the NOVATEC GV series loaders and receivers provides the fastest material changes available with full access, no tools and no material loss.



- **Unique Swing-Out Design**
Provides tool-free access to interior of JIT hopper for easy drain out and cleaning
- **Fast Material Changes**
Glass hopper slides out for full internal access and instant draining, off-throat
- **Tough Borosilicate Glass**
5mm Thick glass provides durable enclosure for material
- **Bolts Easily Onto Injection or Extrusion Throat**
Bolt directly or use convenient adapters
- **Steep Sidewalls**
Provide fast, complete evacuation of material
- **No Material Loss During Changeover**
All residual material can be easily collected with no spillage
- **Easy to Add Purging Compound**
Add purging compound directly to machine throat or to GlassVu Hopper

Plus:

- Aluminum, stainless and borosilicate glass material contact points
- Allows use of grate magnet inside for trapping metal
- Height-adjustable demand sensor, optional
- 5-Year warranty



Application

GlassVu hoppers provide a stable platform on which to mount GlassVu loaders and receivers, converting them for JIT use.

GlassVu Hoppers are designed for use with NOVATEC GlassVu receivers and loaders but may be utilized with most other “flat bottom” loading equipment.



Slides out easily for access and cleaning



Slides off throat for instant draining

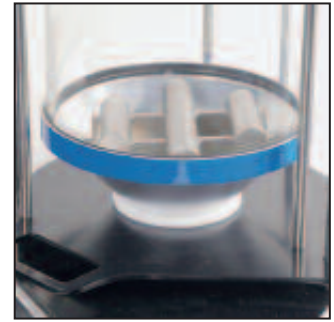

Add optional grate magnet for trapping metal fines

Specifications

Part Number	Capacity*		Volume		A		B		C		D		E	
	lb.	kg	ft.3	liters	in.	cm	in.	cm	in.	cm	in.	cm	in.	cm
GVH-10	10	4.5	.25	7.5	17.6	44.7	12	30.5	8.5	21.6	8	20.3	12	30.5
GVH-25	25	11.3	.63	17.8	23.5	59.7	16	40.6	11.4	29	12	30.5	16.8	42.7

* Based on material bulk density of 38 lb./ft.3 (609kg/m3)

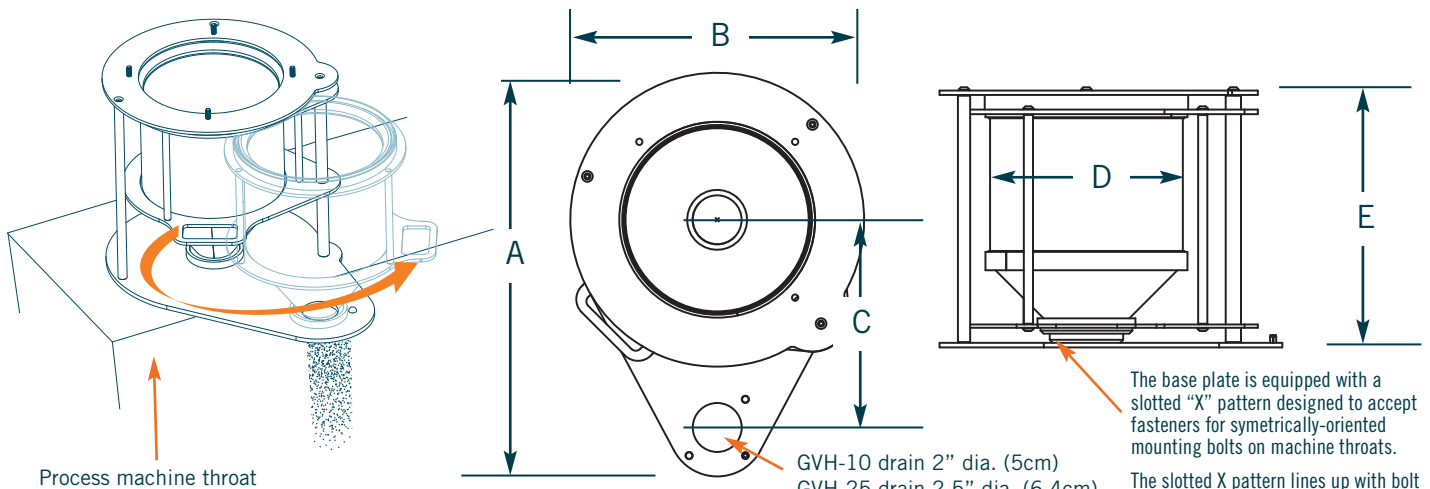

Accessories: (Separate line item on order and shipped separately)

Height adjustable retro-reflective Level Sensor for GlassVu Hopper: Part #kit-C004

Grate Magnet - standard - ceramic: Part Number #hmg-01

Grate Magnet - strong - rare earth: Part Number #hmg-02

Accepting MasterCard, VISA and American Express