

First Standard Color Touch Screen Control on Portable Dry/Convey Wheel Dryers! **STANDARD!!! Not an Upgrade...Not Optional...No additional cost!**

The NovaWheel Portable Dry/Convey Series includes energy saving dryer design. Additional energy savings are realized through the use of an integral central blower rather than vacuum loaders to convey material. The color touch screen control is easier to use than any other dry/convey control. Simply touch the intuitive icons to access the screen related to each icon.

- **Standard Color Touch Screen Control**
Intuitive color touch screen control makes set-up and monitoring of drying/conveying process easier.
- **Automatic Monitoring and Alarm of Dryer Filter Condition**
Operator is alerted when process or regeneration filters need to be cleaned or replaced.
- **Monitoring and Control of all Drying and Conveying Parameters**
All at your finger-tips with intuitive icons and easy-to-understand language.
- **Sensible, Energy-Saving Design Includes:**
 - Energy-saving NovaWheel™ Dryer
 - Slanted control panel for easy viewing of touch screen control
 - Fully Insulated Spun Stainless Steel Hopper with full length sight glass
 - 12 lb. Capacity Stainless Steel Receiver on hopper
 - 5 lb. Capacity Machine Mount Receiver
 - Efficient Blower supplies air for both receivers
 - Dry air conveying
 - Vacuum Purge Valve with slide-gate discharge
 - Cutout access for clean-out bucket
 - Front access to process and regeneration filters
 - 1.5" Flex Hose & Clamps
 - Reduced footprint for more floor space
 - 5" Casters for mobility
 - Top-mounted alarm light



NW-100NC-DC

Additional Features:

- -40° Dew point guaranteed
- Separate process and regeneration blowers
- Process temperatures up to 350°F (177°C) with interlock to heaters
- Open access to all components
- Dew point sensor for process air
- Pre-cooler (Return air)
- 2-Year Warranty

NovaWheel Portable Dry-Convey Models Loaded With Popular Standard Features

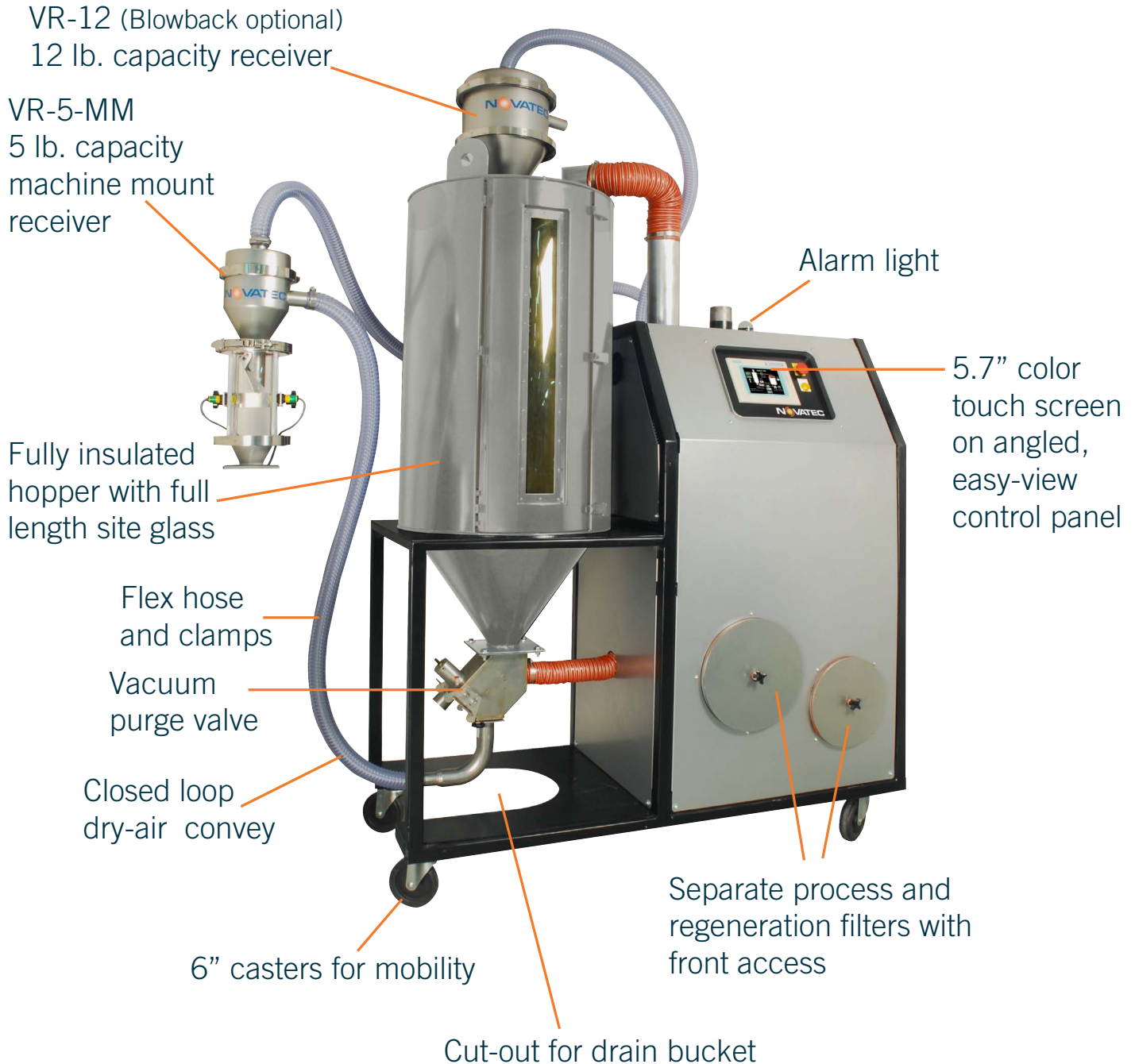

See video at: www.novatec.com/nwdc

Another NOVATEC FIRST...

- No More Confusing Codes.
- No Annoying Function Buttons
- No Manual Look-Ups
- No Additional Cost!

Simply touch any of the intuitive icons to access related screens.

Blower icons change color and alarm icons flash.

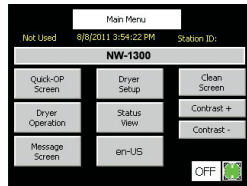

Main Menu

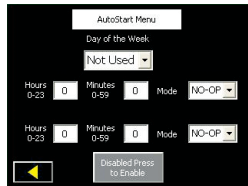

AutoStart Menu

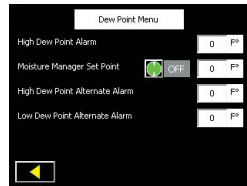

Dew Point Menu

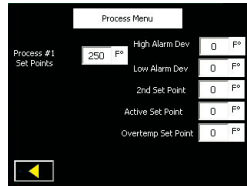

Process Menu

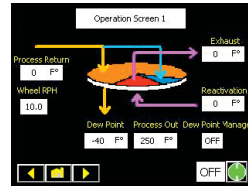

Operation Screen

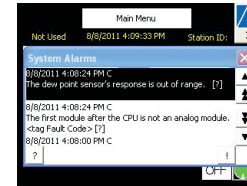

Alarm Screen

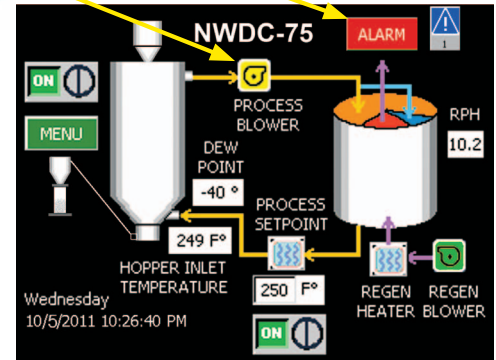
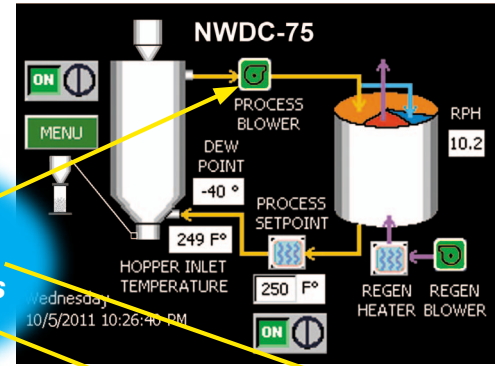

System Alarm
10/5/2011 10:26:40 PM
Process filter warning.
The process filter needs to be cleaned or replaced.

Process and regeneration filter condition is automatically monitored and displayed.

NovaTouch control at no extra charge!

Complete Features	NovaTouch Control
Touch Screen Entry	Standard
Control Temperature #1	Standard
Second Set-point	Standard
Over-temperature Alarm and Shutdown	Standard
Hygro Dew Point Sensor	Standard
Real Time Clock	Standard
Seven Day Timer	Standard
Auto Start/Stop	Standard
High/Low Temperature Alarm	Standard
Warning and Error Messages	Standard
Battery Backup	Standard
EEPROM	Standard
Blower Differential Pressure Switch	Standard
Calibration Feature and Set Point Secure	Standard
Set Deviation Limits	Standard
Language Capabilities	Standard
PLC Diagnostics	Standard
Adjust PID Settings	Standard
NEMA 12 Enclosure	Standard
Loader Operation	Standard

Major features:

- Intuitive Touch Screen for ease of operation
- No confusing alarm codes to look up
- Seven day timer - for auto on/off
- Filter maintenance alerts with oversized filters
- Set points with deviation limits
- Dew point sensor
- Controls loader operation
- Real-time clock with battery backup
- Ethernet option

*Optional Communications Capabilities:

- Ethernet with or without embedded web page
- Modbus
- Modem
- MPI
- Profibus
- DeviceNet
- ASI

*As a PLC based option

Specifications

Model Number	Hopper Capacity		Air Connection		Width		Depth		Height		Throughput Capacity*	Throughput Capacity @ 415/3/50** (no charge)		Throughput Capacity @ 575/3/60**	
	lb.	kg	in.	cm	in.	cm	in.	cm	in.	cm	lb./hr.	kg/hr.	Part# for 415/3/50	kg/hr.	Part# for 575/3/60
NW-75NC-DC	165	75	4	10	59	150	26	66	73	185	75	29	VOLT-NW75-40	34	VOLT-NW75-57
NW-100NC-DC	220	100	4	10	59	150	26	66	79	201	100	38	VOLT-NW100-40	45	VOLT-NW100-57
NW-150NC-DC	330	150	4	10	59	150	26	66	90	229	150	57	VOLT-NW150-40	68	VOLT-NW150-57

* Throughput capacity @ 460V/3ph/60Hz standard voltage - Based on polycarbonate pellets @ 38 lb./ft³

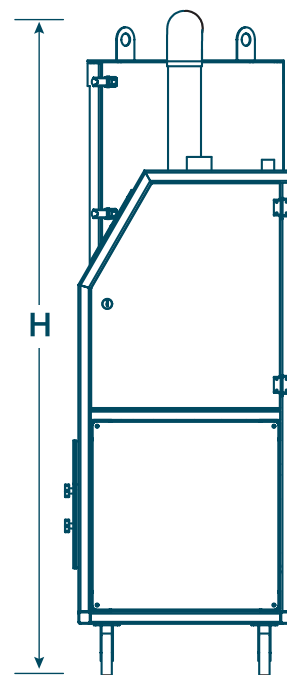
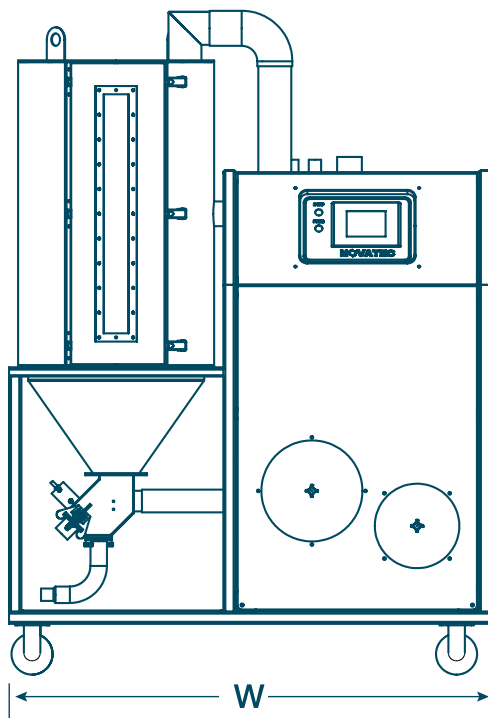
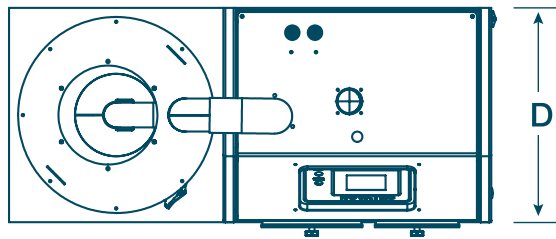

Options:

(Separate line item on order. See price list #102)

** **Alternate Voltages:** See chart above for part numbers.

415/3/50 No charge

575/3/60 Consult factory for price

Vacuum Receiver with Blowback for Drying Hopper: Part# VR-12-B

Networking capability for NovaTouch Color Control:

ColorNet™ Networkable Color HMI: Part# HMI-6S-ColorNet