

## VACUUM LOADERS VL and VLP Series

Models: VL-5, VL-12, VL-19, VL-38  
VLP-5, VLP-12, VLP-19, VLP-38



VL-12 Model Pellet  
and Regrind  
Loader



VL-5-MM  
Machine Mount  
Pellet Loader



Mini PLC  
Self - Contained  
Loader Control



VLP-38 Model  
Powder Loader

© NOVATEC, Inc. 2018 All Rights Reserved

DOCUMENT: VL-VLP IM 2 JULY 2018

# NOVATEC™

Part of the **MAGUIRE** Family

Novatec, Inc. 222 E. Thomas Ave. Baltimore, MD 21225 | [www.novatec.com](http://www.novatec.com)

Phone: 410-789-4811  
Toll Free: 800-938-6682  
Main Fax: 410-789-4638

Parts Email: [parts@novatec.com](mailto:parts@novatec.com)  
Service Email: [service@novatec.com](mailto:service@novatec.com)  
Sales Email: [sales@novatec.com](mailto:sales@novatec.com)

**NOTES:**

Please record the following information, which is specific to this piece of equipment, in the space provided. Our Parts/Service Department will need these numbers to properly respond to any of your requests.

Instruction Manual: VL-VLP IM 2 JULY 2018

Model #: \_\_\_\_\_

Serial # \_\_\_\_\_

**DISCLAIMER:** NOVATEC, Inc. shall not be liable for errors contained in this Instruction Manual nor for misinterpretation of information contained herein. NOVATEC shall not, in any event, be held liable for any special, indirect or consequential damages in connection with performance or use of this information.

## Table of Contents

1-PRINCIPLE OF OPERATION .....	5
2-UNPACKING AND INSPECTION .....	5
3-VL SPECIFICATIONS.....	6
4-VLP SPECIFICATIONS .....	8
5-LOADER INSTALLATION.....	10
5.1 CONTROL INSTALLATION.....	10
6-OPERATION OVERVIEW .....	11
7-NO-LOAD ALARM FEATURE.....	11
8-ADJUSTING the LOADER CONTROL .....	11
8.1 TO ACTIVATE LCD BACKLIGHT.....	12
8.2 TO VIEW SOFTWARE VERSION SCREEN.....	12
8.3 TO CHANGE LOADING PARAMETERS .....	12
8.4 PARAMETERS EXPLANATION.....	12
9-USE OF PROPORTIONING VALVES .....	14
10.1 CONVEYING NOTES.....	15
11 MAINTENANCE .....	15
11.1- VL Series - FLAT FILTER CLEANING: .....	15
11.2- VLP Series - CARTRIDGE FILTER CLEANING:.....	17
11.3- VACUUM MOTOR BRUSH REPLACEMENT .....	18
11.4- VL-12 through VL-38 and VLP-12 through VLP-38 MOTOR BRUSH REPLACEMENT .	19
11.5- VL-5, VLP-5 MOTOR BRUSH REPLACEMENT .....	19
11.6- MOTOR REPLACEMENT .....	20
10-TROUBLESHOOTING .....	21
Warranty Periods: .....	22

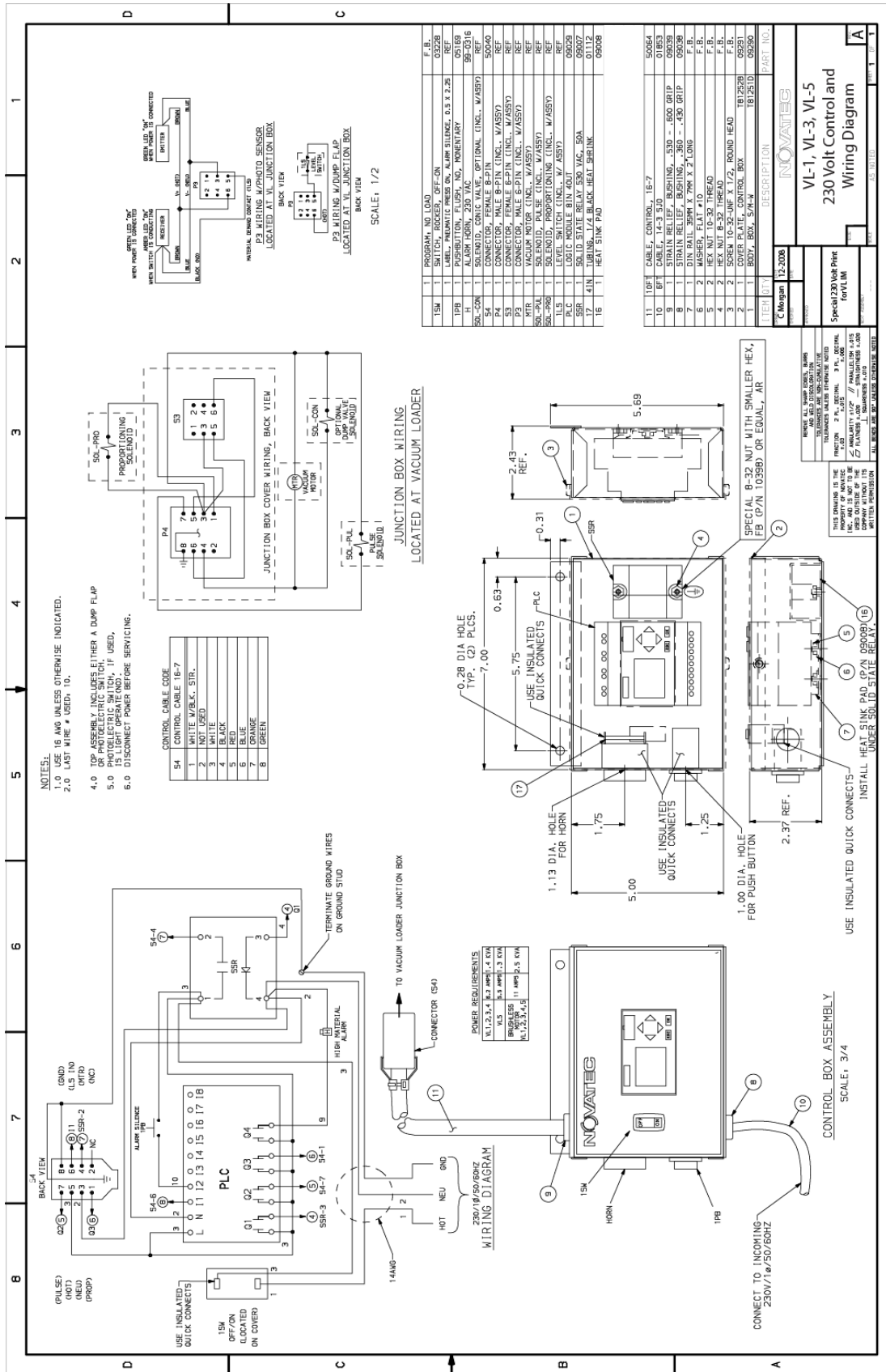

13.0 VL SERIES LOADER PARTS LIST

14.0 VLP SERIES LOADERS PARTS LIST

## **1- PRINCIPLE OF OPERATION**

NOVATEC vacuum loaders utilize a powerful motor to create a vacuum, which draws material into a chamber. After the load time setting has expired, the vacuum motor is turned off and the negative pressure in the chamber is relieved. Material in the chamber then falls through the bottom, past the flapper while compressed air is pulsed through the filter to dislodge any contaminants or fines that may have accumulated. This cycle is repeated as many times as necessary, until the unit is shut off by the rise of the conveyed material in the area below the loader which trips the level switch, removing the 'demand' signal.

Machine mounted units do not have a demand switch actuated by the discharge flapper valve, but instead utilize a remote sensor for demand. The sensor is attached to an adjustable bracket that slides along the length of a clear sight tube serving as a Just-in-Time (JIT) material hopper mounted between the machine throat and loader discharge. The sensor height on the site tube determines the level of material that triggers a demand for more material and a new load cycle. The sensor may be either a capacitance style, with sensitivity adjustment, or a pair of photoelectric sensors, an emitter and a receiver.

The bottom flange is normally supplied undrilled to allow the customer to drill the appropriate mounting pattern for a particular machine.

## **2- UNPACKING AND INSPECTION**

NOVATEC Vacuum loaders are shipped complete, with all controls for automatic operation. The only utilities required are a 115 or 220 volt power supply (depending on voltage of control), and clean, dry compressed air at approximately 80 PSI.

After receipt of the unit, completely inspect it for damage. Although the units are packaged securely, vibration and mishandling during transit can cause damage.

### 3- VL SPECIFICATIONS

NOVATEC VL Series vacuum loaders are completely automatic self-cleaning vacuum loaders designed to convey virgin pellets and regrind materials from storage containers to drying hoppers or directly to process machines.

Machine Mount Models with a sight glass are available as standards for all VL and VLP models.

Each unit is shipped complete with all controls for immediate operation, and include a hardware package. The hardware package includes 15 feet of flexible vacuum hose, hose clamps and a material pick up lance.

Model	VL-5 / VL-5-MM		VL-12 / VL-12-MM		VL-19 / VL-19-MM		VL-38 / VL-38-MM	
	U.S.	Metric	U.S.	Metric	U.S.	Metric	U.S.	Metric
Volume	1/25 ft <sup>3</sup>	1.1 liters	1/3 ft <sup>3</sup>	9 liters	1/2 ft <sup>3</sup>	14 liters	1.0 ft <sup>3</sup>	28 liters
*Resin Capacity	1.5 lb	0.7 Kg	12 lb	6 Kg	19 lb	9 Kg	38 lb	17 Kg
Inlet/Dump Throat OD	1.5/2 in	40/50 mm	1.5/2 in	40/50 mm	1.5/2 in	40/50 mm	1.5/5 in	40/127 mm
**Recommended Throughput / hr (Brush Type Motor)	200 lb	91 Kg	400 lb	181 Kg	500 lb	227 Kg	650 lb	295 Kg
**Recommended Throughput / hr (Brushless Motor)	N/A	N/A	650 lb	295 Kg	1000 lb	454 Kg	1200 lb	544 Kg
Load Time: (seconds)	up to 99		up to 99		up to 99		up to 99	
Dump Time: (seconds)	up to 99		up to 99		up to 99		up to 99	
Amps @115V	8		13		13		13	
Compressed Air Usage .2 CFM (5.66 liters/min)	All Models							

\* Resin capacity and throughput based on 38 lb/ft<sup>3</sup> bulk density. Adding external proportioning valve reduces throughput.

\*\* Recommended throughput/hr based on free flowing virgin pellets through 15' of flex hose. Exceeding recommended throughputs may result in shortened brush and filter life however, increased throughputs are possible depending on resin and equivalent feet calculation. Generally, a central conveying system should be used for higher throughputs. Maximum conveying distance in addition to 15' flex hose, can include 30' of horizontal tubing and 1 elbow. Additional vertical travel, bends or flex hose will reduce recommended throughput.



Standard Dump Throat Models										
Model	A		B		C		D		Shipping Weight	
	in	cm	in	cm	in	cm	in	cm	lb	Kg
VL-5	23	58	17	43	5	13	6	15	50	23
VL-12	28	71	22	56	11	28	10	25	60	27
VL-19	32	81	26	66	15	38	10	25	70	32
VL-38	38	97	29	74	17	43	16	41	80	36

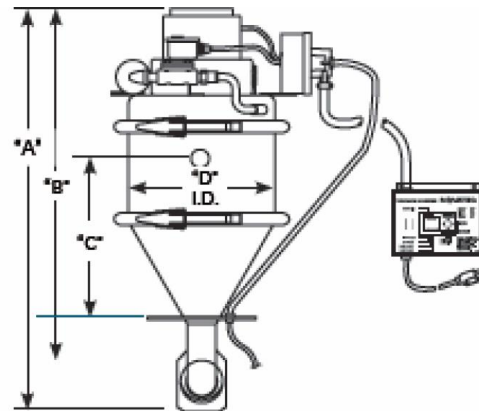

### Machine Mount Model Dimensions Must Specify Glass Hopper Size for All Models:

- \*2 lb Glass: add 3" to "A" above (no charge)
- 8 lb Glass: add 3.7" to "A" above
- 12 lb Glass: add 7.7" to "A" above
- 16 lb Glass: add 10.7" to "A" above
- \*VL-5-MM available with 2 lb glass only

### Accessories:

**External Proportioning Valve:** 1.5" OD (3.6cm) with coupler, wand, hose and clamps.

**Remote Demand Sensor for Grinder Drawer 115 VAC:**  
(Sends demand when covered)

**Field Conversion Kit for existing -MM models:**  
Includes base, glass, top adapter plate and discharge valve.  
8 lb, 12 lb and 16 lb glass

**Brushless Motor Retrofit Kit:**  
For VL-12 through VL-38 models (for 115 VAC only)  
(Replaces existing brush and brushless motors)  
Includes motor, lid and modified J-box with relay.



Brushless Motor  
Retrofit Kit

VL-5, VL-12, VL-19 (2" dump throat)



- 6.25"/159mm dia. hole
- 4 each 0.3125"/8 mm dia. holes equally spaced on a 6.875"/175 mm dia. B.C.

VL-38 (5" dump throat)



- 12"/305 mm dia. hole
- 6 each 0.3125"/8 mm dia. holes equally spaced on a 13"/330 mm dia. B.C.

Mounting Patterns

### Options:

**Alternate Voltages:** 220/1/50-60 in lieu of 115/1/50-60

**Must Specify Glass Hopper Size for All -MM Models:**  
(See P/L #300)

For VL-5-MM: 2 lb glass only (no charge). For VL-12-MM: through VL-38-MM: 2, 8, 12 or 16 lb glass.

**Brushless Motor:** Add -BR to VL model number for VL-12 through VL-38. (Brushless motor adds 2" to overall height)

**Custom Drilling of MM Flange:** (Standard base flange is blank for customer drilling.)

**Extended Wear Package:** Recommended when loading abrasive materials - contact factory.

Machine Mount Adapter  
(Included with MM models)

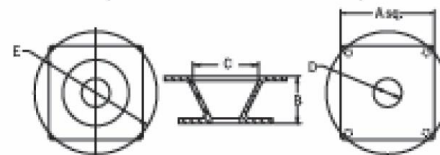

Machine Mount Adapter Dimensions												
Model	Glass Size lb/Kg	A		B		C		D		E		
		in	cm	in	cm	in	cm	in	cm	in	cm	
VL-(5,12, 19 & 38)-MM	2/9	5	12.7	2.5	6.4	3.5	8.9	1.5	3.8	6.5	16.5	
VR-MM-F65**	2/9	6.5	16.5	2.5	6.35	3.5	8.9	2.25	5.7	6.5	16.5	
VR-MM-8, -12, -16***	Varies	6	15.2	5.7	14.5	8	20.3	2	5.1	10	25.4	

\*\* Optional 2 lb glass adapter dimensions    \*\*\* Optional large glass adapter dimensions

#### 4- VLP SPECIFICATIONS

NOVATEC VLP Series vacuum loaders operate in a similar manner to the VL's, but are designed to convey free flowing powders.

Model	VLP-5 & VLP-5-MM		VLP-12 & VLP-12-MM		VLP-19 & VLP-19-MM		VLP-38 & VLP-38-MM	
	U.S.	Metric	U.S.	Metric	U.S.	Metric	U.S.	Metric
Volume	1/25 ft <sup>3</sup>	1.1 liters	1/3 ft <sup>3</sup>	9 liters	1/2 ft <sup>3</sup>	14 liters	1.0 ft <sup>3</sup>	28 liters
Resin Capacity*	1.5 lb	0.7 Kg	12 lb	6 Kg	19 lb	9 Kg	38 lb	17 Kg
Inlet/Dump Throat OD	1.5/2 in	40/50 mm	1.5/2 in	40/50 mm	1.5/2 in	40/50 mm	1.5/5 in	40/127 mm
**Recommended Throughput / hr. (Brush Type Motor)	75 lb	34 Kg	200 lb	91 Kg	250 lb	114 Kg	325 lb	148 Kg
**Recommended Throughput / hr. (Brushless Motor)	N/A	N/A	325 lb	148 Kg	500 lb	227 Kg	600 lb	273 Kg
Load Time: (seconds)	up to 99		up to 99		up to 99		up to 99	
Dump Time: (seconds)	up to 99		up to 99		up to 99		up to 99	
Amps @115V	8		13		13		13	
Compressed Air Usage .2 CFM (5.66 liters/min)	All Models							

\* Resin capacity and throughput based on 38 lb/ft<sup>3</sup> bulk density. Adding external proportioning valve reduces throughput.

\*\* Recommended throughput/hr. based on free flowing virgin pellets through 15' of flex hose. Exceeding recommended throughputs may result in shortened brush and filter life however, increased throughputs are possible depending on resin and equivalent feet calculation. Generally, a central conveying system should be used for higher throughputs.

Maximum conveying distance in addition to 15' flex hose, can include 30' of horizontal tubing and 1 elbow. Additional vertical travel, bends or flex hose will reduce recommended throughput.



**Specifications:**

Overall Dimensions and Weights (Standard Dump Throat Models)										
Model	A		B		C		D		Shipping Wgt.	
	in	cm	in	cm	in	cm	in	cm	lb	Kg
VLP-5	30	76	27	69	9	23	6	15	80	36
VLP-12	40	102	35	89	11	28	10	25	120	55
VLP-19	51	130	45	114	16	41	10	25	140	64
VLP-38	61	155	52	132	17	43	16	41	220	100

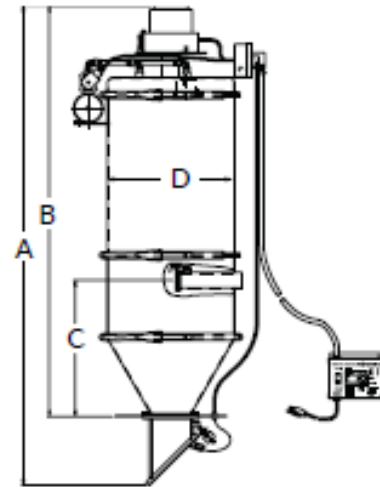
**Mounting Pattern**
**Machine Mount Model Dimensions**

- \*2 lb Glass: add 3" to "A" above
- 8 lb Glass: add 3.7" to "A" above
- 12 lb Glass: add 7.7" to "A" above
- 16 lb Glass: Add 10.7" to "A" above
- \*VLP-5-MM available with 2 lb glass only

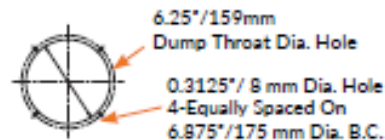
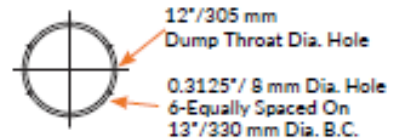
**VLP-5, VLP-12 & VLP-19  
2" Dump Throat**

**VLP-38  
5" Dump Throat**

**Accessories:**

- Air-evacuation filter sub-base
- Remote Demand Sensor for Grinder Drawer: 115 VAC
- External Proportioning Valve: (Includes coupler, 15' of hose, clamps and pickup wand)
- Alternate Glass Hopper for Existing VLP-12-MM, VLP-19-MM and VLP-38-MM: (In lieu of 2 lb)
- Field Conversion Kit: Includes Base, Top Adapter Plate, Discharge Valve and 8, 12 or 16 lb Glass.

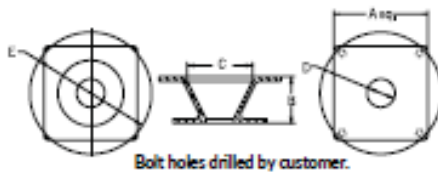
**Options:**

- Alternate Voltage: 230/1/50 in lieu of 115/1/50-60.
- Must Specify Glass Hopper Size for All -MM Models: (See P/L #300)
- For VLP-5-MM: 2 lb Glass only (no charge).
- For VLP-12-MM: through VLP-38-MM: 2, 8, 12 or 16 lb Glass.
- Custom Options:  
Pneumatic Discharge Slide Gate Choice of Components for Wear Resistance: Thick-wall wear plates, electroless nickel plating and ceramic coatings.

**Machine Mount Adapter  
(Included with MM models)**

**Machine Mount Adapter Dimensions**

Model	Glass Size lb/Kg	A		B		C		D		E	
		in	cm	in	cm	in	cm	in	cm	in	cm
VL-(5,12, 19 & 38)-MM	2/9	6.5	16.5	2.5	6.35	3.5	8.9	2.25	5.7	6.5	16.5
VR-MM-8, -12, -16***	Varies	6	15.2	5.7	14.5	8	20.3	2	5.1	10	25.4

\*\* Optional 2 lb Glass Adapter Dimensions  
 \*\*\* Optional Large Glass Adapter Dimensions

## 5- LOADER INSTALLATION

Mount the loader body to the hopper lid, positioning it so that the material inlet is directed towards the material pick up point. Make sure the dump valve flapper plate has enough room to freely operate. Secure the loader to the hopper lid with captive bolts or clamps to ensure a safe installation with no chance of hardware vibrating loose.

On machine mounted units, the bottom flange is usually supplied undrilled to allow a range of mounting patterns and hardware choices. A gasket is used to provide a tight seal between the loader base and the machine throat.

Ensure a tight seal when securing the loader to the hopper or machine. This is particularly important for VLP units that will be conveying powder. The conveying line should be horizontal and/or vertical, using a 90 degree radius bend for directional changes, and it should be as direct as possible with no slope. All line connections should be vacuum tight. Rigid conveying tubing should be properly supported by the installer to provide a safe and secure installation. Use flexible material handling hose to connect the material pick-up lance or vacuum take-off box to the conveying line. The flexible hose should be only as long as needed, since excess hose will reduce loader efficiency.

Connect a clean, dry compressed air supply line to the filter on the accumulator tank. The minimum requirement for effective filter cleaning is 80 PSI.

### CAUTION:

1. DO NOT EXCEED 125 PSI. COMPRESSED AIR.
2. PROPER SUPPORT OF ALL CONVEYING LINES AND A SECURE MOUNTING OF THE HOPPER LOADER IS NECESSARY FOR A SAFE INSTALLATION.

### 5.1 CONTROL INSTALLATION

The VL/VLP control box may be mounted in a location that is convenient for the operator, making sure that the control cable will extend to the junction box on the lid of the hopper loader. The power and connections cables should be carefully routed away from hot components or surfaces and away from high voltage lines that may produce undesirable electrical noise. Connect the control to the power source as required by the nameplate located on the side of the loader control box.

**CAUTION:** FOLLOW ALL NATIONAL and LOCAL ELECTRICAL CODES.

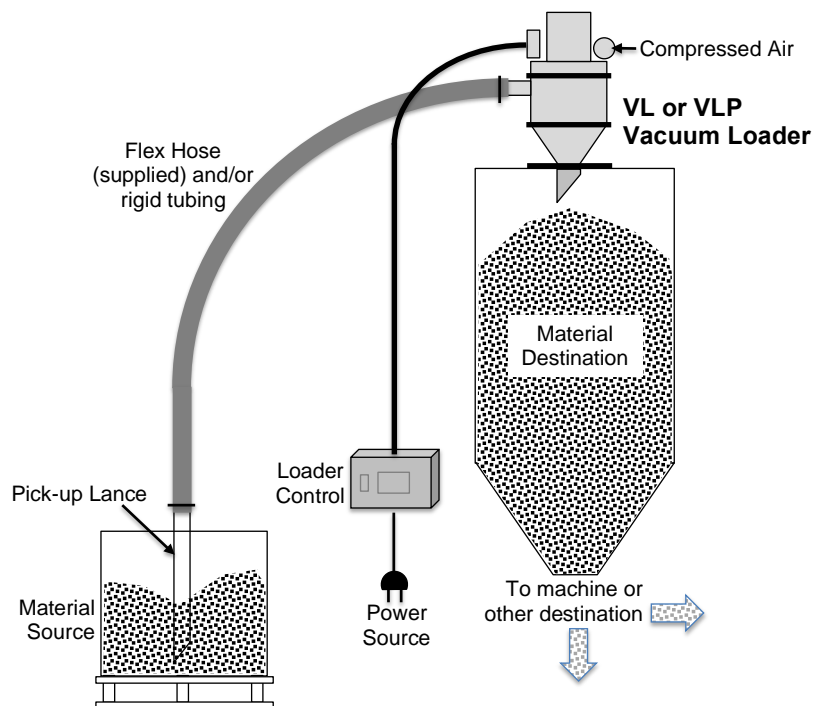

## 6- OPERATION OVERVIEW

Pressing the OFF/ON switch will start the vacuum motor, creating vacuum suction through the conveying line, to the pick-up wand and the loader will load material into the loader's vacuum chamber for an adjustable length of time.

When the load time is completed, the vacuum motor will stop, allowing material in the vacuum chamber to relax and flow through the dump valve to the hopper or machine below. Simultaneously, the filter will be cleaned with pulses of compressed air blown down through the filter media. The dump time and the number of pulses used to clean the filter are adjustable.

Load and dump/pulse cycles will continue until the drying hopper, surge bin or machine hopper below the loader is full, at which time loaded material will either hold the dump valve flapper open or trigger a sensor, placing the system in a holding mode. As material is consumed by the process and flows from the hopper below the loader, the material level will fall, the flapper will close or sensor will be uncovered, and the loader will begin to load automatically again, to keep the hopper full.

**NOTE:** Once the vacuum motor starts, a loading cycle will continue through the load, dump, and pulse cycles, even if the dump flapper is held open. The loader control senses a full condition only after the completion of the dump/pulse cycle.

## 7- NO-LOAD ALARM FEATURE

The No-Load alarm feature monitors the dump flapper on hopper mounted units, to assure it opens as it should by material discharging after loading. If the flapper does not open 3 seconds after the dump sequence has started, the no load alarm on the side of the control will sound. On machine mounted units, the No-Load alarm monitors the photo-eye demand sensor on the glass base to determine if loaded material interrupts the sensor path.

The alarm horn can be silenced with the silence pushbutton on the side of the control.

## 8- ADJUSTING the LOADER CONTROL

The VL and VLP series loaders from NOVATEC employ a Siemens brand, model LOGO! Mini-PLC Control for loading functions. The control is housed in a rugged enclosure and is factory programmed for functions related to vacuum loading.

**NOTE:** The user may adjust certain parameters of the control to fine tune their loader's operation, but changing settings other than those listed can damage control operation.

No-Load Alarm Horn

Alarm Horn Silencer



The control is equipped with a small LCD screen that displays operating and programming prompts, plus pushbuttons to aid in selecting parameters and making changes. A No-Load alarm horn is located on the side of the enclosure along with a silence button.

Instructions listed here are repeated on the control face for ease of use.

### 8.1 TO ACTIVATE LCD BACKLIGHT

- At Home screen (white lit): press ESC key and one of the left/right/down arrows simultaneously. This will provide 30 seconds of backlight. To extend or reactivate the backlight, push the button combination again.
- At Parameters screen (orange lit): pressing any button will activate the backlight.

### 8.2 TO VIEW SOFTWARE VERSION SCREEN

- At Home screen (white lit): press ESC key and up arrow simultaneously. The screen will display software version and revision date.

### 8.3 TO CHANGE LOADING PARAMETERS

1. Press ▼, ESC key and use ▲/▼ to select "Program" and press OK .
2. Select "Set Parameter" and press OK.
3. Select parameter to change and press OK.
4. Select proper sub-parameter if necessary, and press OK.
5. Select desired digit to change using ►/◄.
6. Press ▲/▼ to increase or decrease value, and press OK.
7. Press ESC 4 tims to exit, then ▲ to display home screen.

Load Time:	Pmp/LT
Purge Time:	Pmp/PP
Dump Time:	Pmp/DT
Blowback Count:	BB/Cnt
Alarm Time:	Alm/AT
Alarm Count:	Alm/AC

### 8.4 PARAMETERS EXPLANATION

**Motor-on Time (Pmp/LT)**, measured in seconds, is the amount of time the vacuum motor will run to load material into the loader's vacuum chamber. Too little time will result in insufficient loading and will shorten motor life with too many start/stop cycles. Too much time will pack the loader full of material, prematurely blinding the filter and possibly clogging the conveying line. This setting should be adjusted over the course of several normal loading cycles to 'just fill' (but not overflow) the loader's vacuum chamber. NOTE: VLP series powder loaders include an extended body to house the cartridge filter(s). Loaded material should not be allowed to be filled up into this extended hopper area. It is intended only as a housing for the filter cartridges(s), not a hopper for collecting loaded material.

**Dump Alarm Time (Alm/AT)**, measured in seconds, is the pause time between the completion of Motor On Time and movement of the discharge flapper. This time setting drives the No-Load alarm feature by determining if material was actually loaded and dumped, but prevents false alarms from slow moving material discharge. This setting may be increased if nuisance alarms occur from slow moving material (IE: fluffy grind) that is typically slow to evacuate the loader.

It may be decreased if the No-Load alarm is too slow to respond to your material supply needs (IE: frequent shortages of material flow).

**Dump Alarm Count (Alm/AC)**, This number represents how many consecutive "no-load" alarms will cause the alarm horn to sound.

**Dump Time (Pmp/DT)**, measured in seconds, is the setting for how long the loader will remain at rest after loading, to allow material to evacuate the loader. This setting may be increased in case the material is very slow moving and/or to provide an extended OFF period for the loader (IE: if the loader is used to off-load a granulator).

**Blowback Count (BB/Cnt)**, is the number of blowback pulses that occur following loading for the compressed air system to clean the filter(s). Compressed air is blown down through the filters in the opposite direction of the vacuum loading air, blasting collected fines and dust from the filter media and into the loaded material. Typically, more blasts will clean the filters better and extend the time between manual filter cleaning and provide more efficient loading. However, compressed air is expensive and too many blasts waste this resource. Also, blasts that extend beyond the dump sequence may actually be strong enough to create dusting issues around the loader.

**Prop Valve A Time (PValve/PVA) and Prop Valve B Time (PValve/PVB)**, each measured in seconds, is the amount of time dedicated to the loading of two materials with the use of an optional, external Proportioning Valve. The Proportioning Valve is installed on the material inlet of the VL or VLP loader (see separate instructions, accompanying the valve) and shuttles internal plungers between allowing A (typically virgin) and B (typically regrind) materials to be loaded during the course of the Motor-On time. Time setting A counts down during loading at which time the valve switches to allow the B time setting to take over. A and B will repeat until the Motor-on time expires.

Short A and B time settings will allow multiple 'layers' of virgin and regrind materials to be loaded for rough 'mixing' of the two materials during loading. However, short cycles require each flow of material to start, then stop, possibly resulting in very little material being conveyed to the loader. Trial and error settings of Motor-on time and A and B times are suggested to optimize these settings.

### MATERIAL LOAD TIME = FILL TIME – PURGE TIME

Because the functions are identical, the term PURGE time is used for purging systems *and* pocket conveying systems for cleaning out the conveying line after loading.

**Here it is visually...**

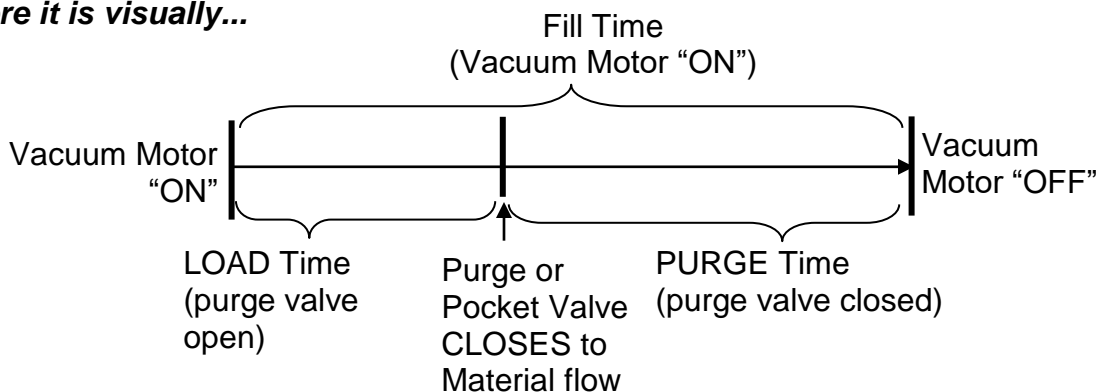

*Times are set in seconds.*



## 9- USE OF PROPORTIONING VALVES

Proportioning valves are a convenient method for introducing regrind into the process while vacuum loading of virgin material. The proportioning valve is typically installed onto the material inlet of the receiver and is connected to the central control system, or an accessory control specifically designed for proportioning valve operation.

Note that a proportioning valve should never be relied upon for *accurate* mixing of two materials, but are only a process convenience for loading a second material (typically regrind). An ideal use of a proportioning valve is emptying a granulator of reground material, in quantities known to not exceed the limitations or specifications of the process.

If requirements for the proportioning require more accuracy, consult with your supplier regarding the use of a blender in lieu of a simple proportioning valve.

### External Proportioning Valve

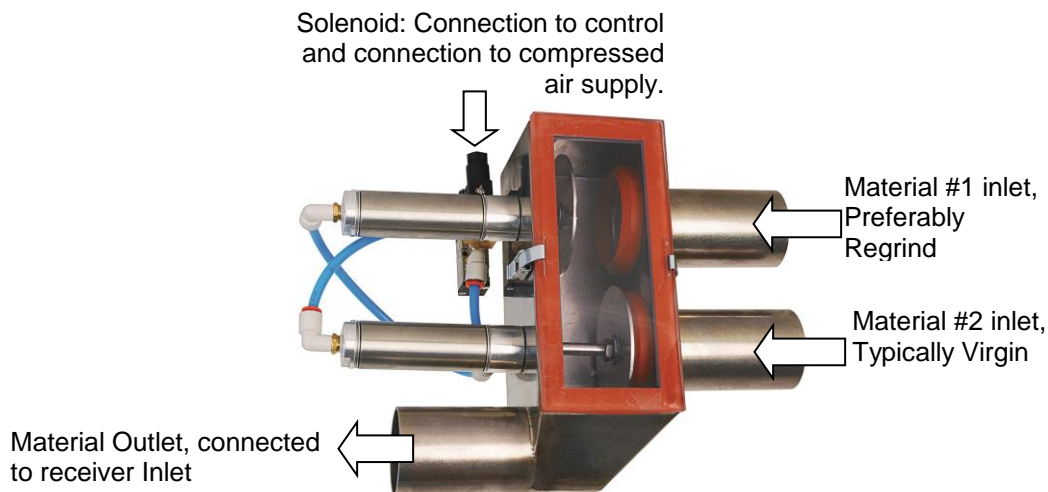

## 10- INITIAL START UP

For optimum loader operation, adjust the load time so that the vacuum chamber is almost completely full at the end of the load cycle. **Do not allow the chamber to overfill.** NOTE: VLP series powder loaders include an extended body to house the cartridge filter(s). Loaded material should not be allowed to be filled up into this extended hopper area. It is intended only as a housing for the filter cartridges(s), not a hopper for collecting loaded material.

Adjust the dump time so that it is only 1 to 2 seconds longer than the time necessary to completely empty the chamber. The number of pulses needed to clean the filter depends upon the material being conveyed. Clean, virgin pellets require minimum filter cleaning while very dusty regrind or powder may necessitate a maximum filter cleaning sequence. Adjust the pulse cycle so the filter(s) remain clean. A mid range setting is suggested as a starting point.



## 10.1 CONVEYING NOTES

Materials, which contain a large percentage of fines or powder, may require increased filter cleaning. This can be achieved by the following technique.

- A) Set the load time to minimum.
- B) Set the dump and pulse time to maximum.
- C) Increase the compressed air pressure. **CAUTION: DO NOT EXCEED 125 PSI.**

## 11 MAINTENANCE

**CAUTION: Disconnect electrical power and compressed air supplies before any type of loader maintenance.**

Typical maintenance for self-contained vacuum loaders consists of two main areas: Filter cleaning and motor brush replacement.

### 11.1- VL Series - FLAT FILTER CLEANING:

VL Series loaders are typically used for conveying virgin pellets and/or regrind. The amount of dust within the conveyed materials will determine the frequency of necessary manual filter cleaning.

NOTE: Although the blowback system of the VL loaders will extend the operational life of the filter media, it cannot be relied upon alone. Frequent checks of the filter accompanied by thorough manual cleanings are required, in addition to cleanings during material changes to prevent cross contamination.

The filter media may be removed for inspection and cleaning by unclamping the ring clamp of the lid, directly below the motor. If necessary, unplug the control cable and disconnect the air line.

Carefully remove the motor lid and expose the flat filter directly below the lid. The filter may now be removed for inspection and cleaning.

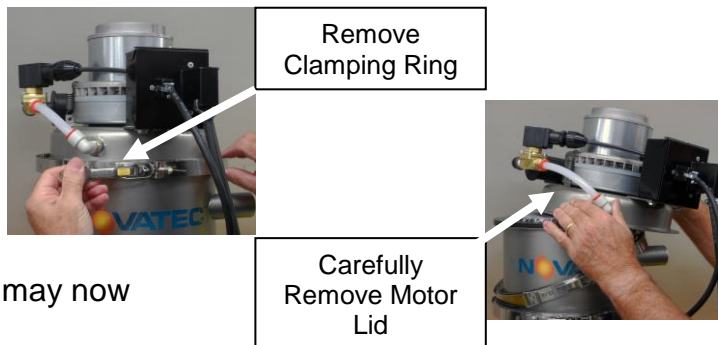

*Vacuum cleaning the bottom of the filter is recommended to remove collected resin debris, dust and fines. If compressed air is used, be sure to wear goggles and blow from the top (coarse screen side) of the filter down through the filter media. Never bang the filter against a hard surface to dislodge debris. Distortion of the media or sealing ring can result.*



Once clean, thoroughly inspect the filter for severe wear, holes, tears and material abrasion. Any break in the filter media indicates the need for new filter. Do not attempt to repair the media. Remember that the filter protects the vacuum motor and holes or any kind of leakage through the filter can allow material to pass into and through the motor, severely shortening the motor's life,

possibly creating a fire hazard and sending material dust into the air around the loader. In addition, examine the sealing ring around the filter media.

This ring provides the vacuum seal between the motor lid, the filter and the loader body.

The ring must be smooth, clean and intact to provide a suitable seal for vacuum sealing. Replace the filter if the seal is not in perfect shape.

Once cleaning/inspection is complete, the filter may be reinstalled by placing it on the flat rim of the loader body (cloth DOWN and coarse screen UP) and placing the motor lid down upon it and centering the filter between the two. Replace the clamp and tighten. With newly installed filters, the clamp may need to be adjusted to provide a vacuum-tight and mechanically firm seal.



### 11.2- VLP Series - CARTRIDGE FILTER CLEANING:

VLP Series loaders are typically used for conveying free flowing powder materials. For this task, they are equipped with higher capacity cartridge filters. The amount of dust within the conveyed materials will determine the frequency of necessary manual filter cleaning.

NOTE: Although the blowback system of the loader will extend the operational life of the filter media, it cannot be relied upon alone. Frequent checks of the filter accompanied by thorough manual cleanings are required, in addition to cleanings during material changes to prevent cross contamination.

CAUTION: Disconnect electrical power and compressed air supplies before any type of loader maintenance.

The cartridge filter(s) may be removed for inspection and cleaning by unclamping the ring clamp of the lid, directly below the motor. If necessary, unplug the control cable and disconnect the air line. Carefully remove the motor lid and expose the cartridge filter mounting plate directly below the lid. The cartridge filter mounting plate, with the cartridge filter(s) installed below it may now be carefully removed for inspection and cleaning.

If only light cleaning of the cartridge filter(s) is required, the filter(s) may remain installed onto the filter plate and cleaned in place. However, full removal and thorough cleaning of each cartridge is highly recommended.

*Vacuum clean the outside of the filter(s) to remove collected resin debris, dust and fines. If compressed air is used, be sure to wear goggles and blow from the inside of the filter(s) down through and out of the filter media. Never bang the filter(s) against a hard surface to dis-lodge debris. Distortion of the media or sealing ring(s) can result.*

If compressed air is used, blow down through the inside to the outside.

Vacuum Cleaning of filter(s) exterior is recommended

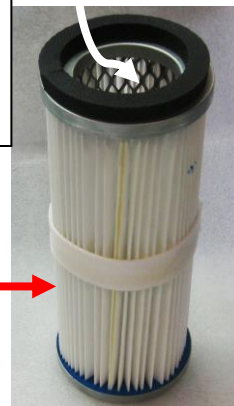

VLP Cartridge Filter

Once clean, thoroughly inspect the filter(s) for severe wear, holes, tears and material abrasion. Any break in the filter media indicates the need for new filter cartridge. Do not attempt to repair the media. Remember that the filter protects the vacuum motor and holes or any kind of leakage through the filter can allow material to pass into and through the motor, severely shortening the motor's life, possibly creating a fire hazard and sending material dust into the air around the loader. In addition, examine the sealing ring around the top of each filter cartridge. This seal provides the vacuum seal between the cartridge filter and the filter mounting plate and must be fully intact. Replace the cartridge if this seal is not perfect.

NOTE: Polyester filter cartridges, supplied as standard with all NOVATEC VLP loaders are washable to extend their life. Use only clean water, sprayed at medium pressure through the media from the inside out to remove dust and debris. The cartridge must be thoroughly dried before being put back into service. A commercial drying device may be used, or the cartridge can be thoroughly drained of water and water droplets and left to dry for no less than 24 hours.

Once each cartridge is cleaned, completely dry and inspected, it may be re-installed onto the filter mounting plate in the same fashion it was removed. Examine the filter mounting plate to be sure it is intact and its perimeter seal is smooth and clean since it will form a vacuum tight seal between the motor lid, the filter mounting plate and the loader body. Replace the seal if it is not in perfect shape.

Once filter cartridge(s) are mounted to the filter mounting plate, it may be reinstalled by placing it on the flat rim of the loader body with the cartridges down inside the loader body. At this point, it is critical that each cartridge filter is located directly below a blowback nozzle that cleans it during the blowback sequence (this step not required for single cartridge units). By viewing the motor lid and the blowback nozzles on the underside of it, the filter plate may be rotated into proper position prior to placing the motor lid down upon it and centering the filter between the two. Each blow down jet on the lid must be centered over a cartridge filter for effective blowback action. Replace the clamp and tighten. With newly installed filter plate seals, the clamp may need to be adjusted to provide a vacuum-tight and mechanically firm seal.

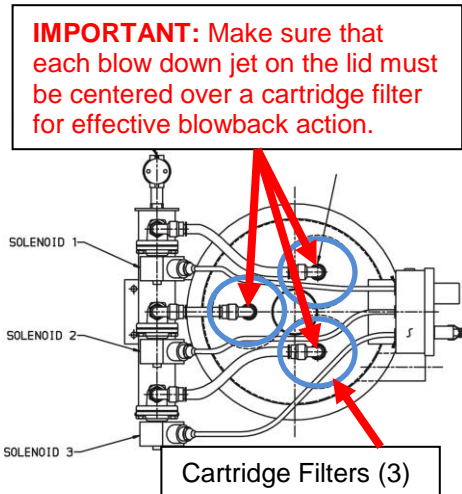

### 11.3- VACUUM MOTOR BRUSH REPLACEMENT

Brushes should be examined for wear and changed **before** the brush holder or non-brush components touch the commutator of the motor. Estimated brush life is approximately 300 running hours under normal operating conditions. See next page for detailed brush changing instructions. To achieve best performance, new brushes should be seated on the commutator before full voltage is applied. The motor manufacturer recommends the following procedure:

*After brush change, apply 50% to 70% of rated voltage for thirty minutes to accomplish the seating. The motor will return to full performance after thirty to forty-five minutes of operating at full rated voltage. The motor must not be run with the vacuum inlet sealed off.*

Direct application of full rated voltage after changing brushes will cause arcing, commutator pitting, and reduced overall life. However, if reduced voltage is unavailable; connecting two motors of similar rating in series for thirty minutes will accomplish the proper brush seating.

**CAUTION:** Disconnect electrical power before any type of loader maintenance.

Removing the vacuum motor from the loader lid is recommended prior to changing brushes.

### 11.4- VL-12 through VL-38 and VLP-12 through VLP-38 MOTOR BRUSH REPLACEMENT

1. Remove metal band from mid-section of motor by unscrewing the sheet metal screw in the side. Pull the cover back away from the motor, sliding it gently over the wires that pass through the grommet opposite the screw. The brushes are visible inside, towards the base of the motor.
2. Remove the screws on each side of each brush that hold the brush retaining clip. A screwdriver may be inserted through the holes in the top of the motor to aid in this process. Remove the clip carefully to be sure nothing drops into the motor fan housing opening towards the middle of the motor.
3. The brush is contained within a plastic holder and is connected to the electrical lead through a spade lug terminal. Gently pull or pry the lug off the brush holder taking care to not damage the lead or the lug.
4. New brush may be installed by reversing the above steps. When securing the brush in the motor housing with the retainer clip, be sure the brush is properly nested in the motor frame before securing the screws.
5. Repeat steps 2 thru 4 for the adjacent brush.
6. Replace the metal band onto the mid-section, while carefully routing the wires through the grommet. It is notched to fit in only one position. Secure with single screw. Reinstall cover over motor.

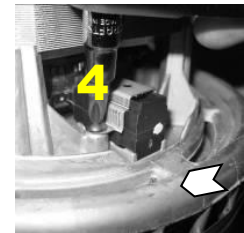
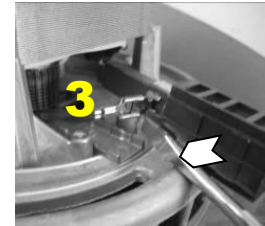
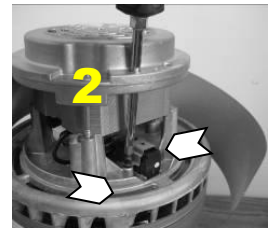
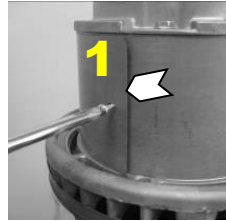

### 11.5- VL-5, VLP-5 MOTOR BRUSH REPLACEMENT

Remove metal cover from motor.

1. Remove plastic shield from top of motor by squeezing the top of each spring clip (A) while prying the cover up away from colored brush holder (green-120 volts, red-220 volts). Cover can be worked up and off, one side at a time.

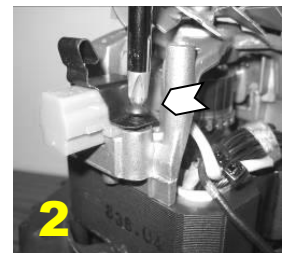
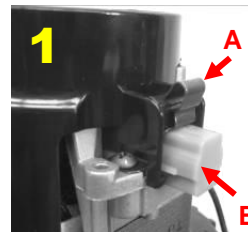

Take care to not break small positioning stubs and grip tabs (B) on the plastic cover.

2. Remove two black screws that hold down brush retaining clip. Once removed, brush will be released, but still connected to the short electrical lead. Use caution to avoid damaging the lead.
3. Pry electrical lug out of the brush holder in the direction of the motor armature, taking care to not separate the wire from the lug.
4. New brush may now be connected to the electrical lead by reversing this procedure. Push the lug firmly between the brass brush holder and its plastic housing.

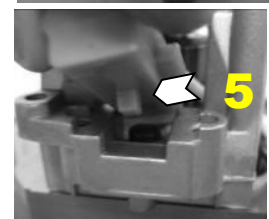
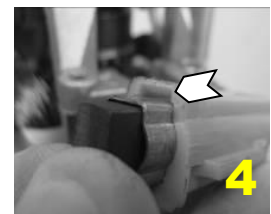
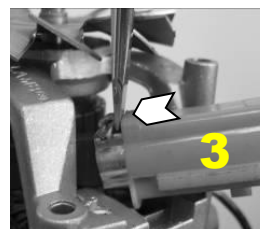

5. Reinstall new brush into motor housing and replace the retaining clip. Be sure to properly seat the nub on the bottom of the brush holder into the motor housing groove.
6. Repeat steps 2 thru 5 for the adjacent brush.
7. Replace the plastic shield on top of the motor by aligning it on top of the motor and pushing down until the spring clips on each brush snap into place.
8. Reinstall metal cover over motor.

### **11.6- MOTOR REPLACEMENT**

Disconnect all power from the loader system. Disconnect the motor wiring from the junction box located on the lid of the chamber. Remove the three springs that clamp the motor to the lid. The motor can now be removed. Check the gasket that seals the vacuum motor to the lid and renew if necessary. Reverse the above steps to install the vacuum motor. Connect power and verify that the system is operating correctly.



## 10- TROUBLESHOOTING

Most loader problems are a result of a dirty filter, air leaks or improper adjustments. These items should be checked before assuming equipment failure.

<u>Problem</u>	<u>Investigate</u>
Motor will not run	A, B, C, H, and L
Inadequate or no vacuum	D, E, F, G, J
Inadequate or no material flow	D, E, F, and G, I, K
Motor runs but proportioning solenoid not operating	L

<u>CHECK</u>	<u>CONDITIONS</u>	<u>SOLUTION</u>
A. Power Supply	No voltage or voltage incorrect	Check incoming power supply voltage at outlet
B. Stop/Start Switch	No voltage through switch	Replace switch
C. Vacuum motor	No voltage at motor	See A,B, & L
D. Filter	Filter dirty	Replace filter (Also see G & J)
E. Air Ducts	Obstructed	Remove obstruction
F. Leaks in system	Air leaking into system	Replace gaskets & repair leaks as necessary
G. Blowback air pressure incorrect	Low pressure	Increase pressure (not to exceed 125 psi)
H. Limit switch	No voltage through switch	Replace switch
I. Load Time	Chamber not filling sufficiently Chamber over-filling	Increase load time Decrease load time
J. Pulse rate	Insufficient to clean filter	Increase rate
K. Dump time	Insufficient to allow complete emptying of chamber	Increase time
L. Pulse solenoid	Correct voltage at solenoid	Replace solenoid

## 11.0 WARRANTY- NOVATEC, INC. - Effective Date 7 FEBUARY 2018

NOVATEC, INC. offers COMPREHENSIVE PRODUCT WARRANTIES on all of our plastics auxiliary equipment. We warrant each NOVATEC manufactured product to be free from defects in materials and workmanship, under normal use and service for the periods listed under **"Warranty Periods"**. The obligation of Novatec, under this warranty, is limited to repairing or furnishing, without charge, a similar part to replace any part which fails under normal use due to a material or workmanship defect, within its respective warranty period. It is the purchaser's responsibility to provide Novatec with immediate written notice of any such suspected defect. Warranted replacement parts are billed and shipped freight pre-paid. The purchaser must return the suspect defective part, freight prepaid and with identifying documentation to receive full credit for the part returned. Novatec shall not be held liable for damages or delay caused by defects. No allowance will be made for repairs or alterations without the written consent or approval of Novatec.

The provisions in equipment specifications are descriptive, unless expressly stated as warranties. The liability of Novatec to the purchaser, except as to title, arising out of the supplying of the said equipment, or its use, whether based upon warranty, contract or negligence, shall not in any case exceed the cost of correcting defects in the equipment as herein provided. All such liability shall terminate upon the expiration of said warranty periods. Novatec shall not in any event be held liable for any special, indirect or consequential damages. Commodities not manufactured by Novatec are warranted and guaranteed to Novatec by the original manufacturer and then only to the extent that Novatec is able to enforce such warranty or guaranty. Novatec, Inc. has not authorized anyone to make any warranty or representation other than the warranty contained here. Non-payment of invoice beyond 90 days will invalidate the warranty. A renewed warranty can be purchased directly from Novatec.

Please note that we always strive to satisfy our customers in whatever manner is deemed most expedient to overcome any issues in connection with our equipment.

### **Warranty Periods:**

Note: All warranty periods commence with the shipment of the equipment to the customer.

### **5-Year (Except 1-Year on Non-Novatec Buy-Out Items)**

#### **Resin Drying to Include**

NovaWheel™ Dryers \*  
Dual Bed Dryers  
NovaDrier \*  
NDM-5 Membrane Dryer  
Gas-Fired Process Heaters  
Gas-Fired Regeneration Heaters  
Drying Hoppers  
Central Drying Hopper Assemblies  
Heater/Blower Units and Hot-Air Dryer  
Silo Dehumidifiers  
NovaVac Dryers \*  
Nitrogen NovaDriers (Nitro)  
DryTemp Plus

#### **Central System Controls to Include**

FlexTouch™ Series Controls  
FlexXpand™ Series Controls  
OptiFlex™ Series Controls  
PLC Communications Modules  
Greenboard Communications Modules  
LOGO! Mini PLC  
MCS-600 Series Controls – (Distributed I/O)  
MCS-400 Series Controls  
CL Silo Manager

#### **Moisture Measurement Equipment to Include**

MoistureMaster®

#### **PET Resin Crystallizers**

#### **Resin Blending and Feeding to Include**

WSB Blenders, MaxiBatch & Feeders \*  
Gaylord Sweeper Systems

#### **Downstream Extrusion Equipment to Include**

C and NC Bessemer Series Cutters  
NPS Bessemer Series Pullers  
NPC Mini Puller/Cutter  
All NS Series Servo Saws  
All Cooling and Vacuum Tanks Manufactured by Novatec

#### **Resin Conveying and Systems Components to Include**

GSL Series Vacuum Loaders  
GlassVu Loaders, Receivers and Hoppers  
VL/VLP Series Loaders  
VRH, VR, VR-FL & VRP Series Receivers  
Compressed Air Loaders  
AL-B Barrel Loader  
Cyclone Dust Collectors  
Conveying System Accessories  
Surge Bins  
Valves and Accessories  
Electronic Metal Separators  
Quick Select Manifolds  
Tilt Tables  
Filter Dust Collectors  
Drawer Magnets  
Velocity Control Valves

### **3-Year**

#### **Resin Conveying System Components to Include**

\*\* VPDB Vacuum Positive Displacement Pumps  
\*\* SVP Vacuum Pumps  
\*\* MVP Vacuum Pumps  
\*\* Railcar Unloading Systems

**\*\*5-Year Extended Warranty** - When a MachineSense® data plan is activated for products with \*\*, Novatec automatically extends the warranty to 5 years. The data plan must be activated within 60 days after product shipment, and remain active through the warranty period to maintain extended warranty eligibility. The first 6-months of data plan usage is free from Novatec.

### **1-Year**

Infrared Dryers  
UltraVac Vacuum Pumps

Vacuum Regenerative Blower Pumps  
Custom Equipment of any kind unless otherwise specified

**Exclusions:**

Routine maintenance/replacement parts are excluded from the warranty. These include, but are not limited to: hoses, desiccant, filters, filter elements, wiper seals, gaskets, dew point sensors, infrared lamps, motors, internal solenoids, fuses and motor brushes. Use with abrasive materials will void the warranty of any standard product. Wear resistant options may be available to extend usable service life with abrasive materials. Novatec reserves the right to limit the warranty if the customer installs replacement parts that do not meet the specifications of the original parts supplied by Novatec.

**\*Specific Exclusions:**

1. NovaDrier and NovaDrier-Nitrogen (NITRO) warranty is void if coalescing filters are not replaced on a 6-month or yearly basis (per instruction manual) and/or membrane has been exposed to ozone.
2. NovaVac Dryer -The ability of the canisters to hold vacuum will be compromised if the vacuum seal edge is damaged from mishandling. We do not warranty canisters damaged from improper handling. We do, however, warranty the seals.
3. LOAD CELLS on our WSB's are covered by Novatec standard warranty as long as they have not been damaged from improper handling.
4. Desiccant Wheel Warranty will be void if the wheel has been exposed to plasticizer, dust or other contaminants as a result of negligence on the part of the processor.

**This warranty shall not apply to equipment:**

1. Repaired or altered without written approval of NOVATEC unless such repair or alteration was, in our judgment, not responsible for the failure
2. Which has been subject to misuse, negligence, accident or incorrect wiring by others
3. Warranty is void if processing rates exceed manufacturer-recommended levels or if damage is caused by ineffective power isolation and/or power spikes/sags or incorrect installation.

NOTE: All conditions and content of this warranty are subject to changes without notice.





04533	Brush set for #04250 Vacuum Motor	For VLP-5
50036	Carbon Brushes, set of two	Carbon Brushes, set of two, for motor part #50033 & 01381. VLP-12, -19, -38
04505	Deflector Assembly, Articulated, 1.5"	Deflector assembly for 1.5" line size.
08989	Dump Flapper for MM, Aluminum	Dump Flapper, Aluminum (flapper only) for Machine Mount Dump Flapper assembly (#09662)
01-1664	Dump Flapper for MM, SS	Dump Flapper, Stainless Steel (flapper only) for Machine Mount Dump Flapper assembly (#09662)
09662	Dump Valve assembly for Machine Mount, with Flapper	Dump Valve assembly with Aluminum Flapper, for Machine Mount assemblies.
02778	Dump Valve Flapper, 2" Aluminum	
08598	Dump Valve Flapper, 2" SS	
02155	Dump Valve Flapper, Optional SS, for 5" dump valve	Optional Stainless Steel Flapper for the 5" dump valve used on VLP-12, -19, -38
50210	Dump Valve Flapper, Standard Aluminum, for 5" dump valve	Standard Aluminum Flapper for the 5" dump valve used on VLP-12, -19, -38.
11644	Filter Cartridge - 4" O.D. X 10" long (3) required for VLP-12 and VLP-19 (1) required for VLP-5	
11645	Filter Cartridge - 6" O.D. x 20" long (3) required	For VLP-38
KIT-S0018	Filter Cartridge Kit - Includes: (3) of part #11645 Filter Cartridge, 6" OD X 3.5" ID x 20"Lg, Polyester W/PTFE	For VLP-38
KIT-S0016	Filter Kit, includes three (3) of part #11644 Filter Cartridge	Kit includes three (3) of part #11644, Filter Cartridge, 4 OD X 2.5 ID X 10Lg, Polyester W/PTFE, 1 Micron. For VLP-12, -19
01695	Gasket seal, 3", Standard Neoprene Black, (200 degree F)	Standard Neoprene (200 degree) Gasket, 3" (Nominal); Used for the Standard Discharge Gasket for the 2" dump valve.
50026	Gasket seal, 5", Standard Neoprene black, (200 degree)	Standard Neoprene (200 degree) Discharge Gasket for the 5" dump valve, 6.875" diameter
exhs-m001	Magnetic Reed Switch	SPST, 180 volt rating
Exhs-m002	Activation Magnet	For reed switch
09029	PLC, LOGO, 230RC, 115-230vac	
08758	Sight Glass, Tube, 3.5" diameter x 8" long	Tube Borosilicate Glass, 3.5" OD, 8" Long
09007	Solid State Relay, 115vac	
04250	Vacuum Motor, 115 volts AC	For VLP-5
50033	Vacuum Motor. 115 Volts AC	For VL-12,-19,-38
09758	VL Controller, complete, 115vac	Replacement VL control box, complete with LOGO mini-PLC controller, line cable and plug and interconnect cable with 8 pin gang plug. 115vac operation
097581	VL Controller, complete, 230vac	Replacement VL control box, complete with LOGO mini-PLC controller, line cable and plug and interconnect cable with 8 pin gang plug. 230vac operation
asVR-MM-8	8 lb. Sight Glass Conversion Kit	Conversion Kit to increase sight glass capacity for VL & VLP-12 and -19 models. Includes base, borosilicate glass, top adapter plate and discharge valve.
asVR-MM-12	12 lb. Sight Glass Conversion Kit	
asVR-MM-16	16 lb. Sight Glass Conversion Kit	

## 14.0 VLP SERIES LOADERS PARTS LIST

Part #:	Description	Additional Information
---------	-------------	------------------------



04533	Brush set for #04250 Vacuum Motor	For VLP-5
50036	Carbon Brushes, set of two	Carbon Brushes, set of two, for motor part #50033 & 01381. VLP-12, -19, -38
04505	Deflector Assembly, Articulated, 1.5"	Deflector assembly for 1.5" line size.
08989	Dump Flapper for MM, Aluminum	Dump Flapper, Aluminum (flapper only) for Machine Mount Dump Flapper assembly (#09662)
01-1664	Dump Flapper for MM, SS	Dump Flapper, Stainless Steel (flapper only) for Machine Mount Dump Flapper assembly (#09662)
09662	Dump Valve assembly for Machine Mount, with Flapper	Dump Valve assembly with Aluminum Flapper, for Machine Mount assemblies.
02778	Dump Valve Flapper, 2" Aluminum	
08598	Dump Valve Flapper, 2" SS	
02155	Dump Valve Flapper, Optional SS, for 5" dump valve	Optional Stainless Steel Flapper for the 5" dump valve used on VLP-12, -19, -38
50210	Dump Valve Flapper, Standard Aluminum, for 5" dump valve	Standard Aluminum Flapper for the 5" dump valve used on VLP-12, -19, -38.
11644	Filter Cartridge - 4" O.D. X 10" long (3) required for VLP-12 and VLP-19 (1) required for VLP-5	
11645	Filter Cartridge - 6" O.D. x 20" long (3) required	For VLP-38
KIT-S0018	Filter Cartridge Kit - Includes: (3) of part #11645 Filter Cartridge, 6" OD X 3.5" ID x 20"Lg, Polyester W/PTFE	For VLP-38
KIT-S0016	Filter Kit, includes three (3) of part #11644 Filter Cartridge	Kit includes three (3) of part #11644, Filter Cartridge, 4 OD X 2.5 ID X 10Lg, Polyester W/PTFE, 1 Micron. For VLP-12, -19
01695	Gasket seal, 3", Standard Neoprene Black, (200 degree F)	Standard Neoprene (200 degree) Gasket, 3" (Nominal); Used for the Standard Discharge Gasket for the 2" dump valve.
50026	Gasket seal, 5", Standard Neoprene black, (200 degree)	Standard Neoprene (200 degree) Discharge Gasket for the 5" dump valve, 6.875" diameter
exhs-m001	Magnetic Reed Switch	SPST, 180 volt rating
Exhs-m002	Activation Magnet	For reed switch
09029	PLC, LOGO, 230RC, 115-230vac	
08758	Sight Glass, Tube, 3.5" diameter x 8" long	Tube Borosilicate Glass, 3.5" OD, 8" Long
09007	Solid State Relay, 115vac	
04250	Vacuum Motor, 115 volts AC	For VLP-5
50033	Vacuum Motor. 115 Volts AC	For VL-12,-19,-38
09758	VL Controller, complete, 115vac	Replacement VL control box, complete with LOGO mini-PLC controller, line cable and plug and interconnect cable with 8 pin gang plug. 115vac operation
097581	VL Controller, complete, 230vac	Replacement VL control box, complete with LOGO mini-PLC controller, line cable and plug and interconnect cable with 8 pin gang plug. 230vac operation
asVR-MM-8	8 lb. Sight Glass Conversion Kit	
asVR-MM-12	12 lb. Sight Glass Conversion Kit	Conversion Kit to increase sight glass capacity for VL & VLP-12 and -19 models. Includes base, borosilicate glass, top adapter plate and discharge valve.
asVR-MM-16	16 lb. Sight Glass Conversion Kit	