



Cyclone Dust Collectors

Protects the vacuum pump and reduces filter maintenance by collecting up to 99% of dust and fines before they reach the pump.

CDC series, cyclone dust collectors provide highly efficient separation of carry over dust and fines from conveying air. These fines can be easily emptied from a sealed dust collection pan or drum under the CDC.

**— 5 —
YEAR
warranty**



Cyclonic Action

Removes up to 99% of carry over fines that are drawn towards the central pump in a vacuum conveying system.

Easy Access

Simple clamp-on collection pan with cradle support allows easy removal and re-assembly when emptying fines.

Free Standing

May be located anywhere between the pump filter and the conveying system.

Rugged Construction

Heavy gauge steel construction, robust formed channel leg supports with floor mounting tabs. Welded body, tube stubs, and mounting brackets.

Solenoid Valve on Discharge

Wired to pumps vacuum breaker valve on CDC-D models equalizes pressure inside the cyclone to ensure quick discharge.

Two Configurations Available

Base model features an air-tight collection pan. A drum dump model on an elevated frame has a discharge flapper valve and dust sleeve for collecting large quantities of dust and fines in a drum. (Drum optional)

Collection Pan Construction



See-through catch pan



Steel catch pan with site glass

CDC-15-ST through CDC-30-ST now include a see-through collection pan. The CDC-40 model has the steel version. Both are easily removable.

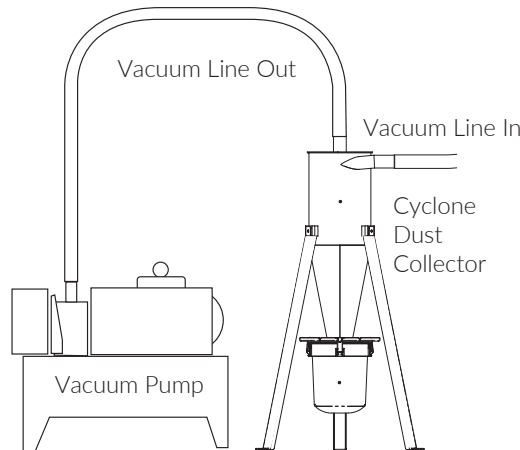

NEW! Base models are shipped with freight-saving bolt-together construction with quick assembly instructions attached to each unit.

Plus

- > 24 VDC Standard CDC-D
- > 5-Year warranty

Specifications:

Dimensions – Collection pan on discharge

Part Number	CDC-15-ST		CDC-20-ST		CDC-25-ST		CDC-30-ST		CDC-40	
	U.S.	Metric	U.S.	Metric	U.S.	Metric	U.S.	Metric	U.S.	Metric
Inlet O.D.*	1.5"	3.8 cm	2"	5.1 cm	2.5"	6.35 cm	3"	7.6 cm	4"	10.2 cm
Air Volume	70 cfm	118 m ³ /hr	120 cfm	203 m ³ /hr	195 cfm	330 m ³ /hr	250 cfm	423 m ³ /hr	500 cfm	845 m ³ /hr
Height	58"	147 cm	58"	147 cm	62"	158 cm	62"	158 cm	79"	201cm
Base diameter	31.2"	79 cm	31.2"	79 cm	35.5"	90 cm	35.5"	90 cm	41"	104 cm
Shipping Wgt.	165 lb	75Kg	170 lb	77Kg	190 lb	86Kg	210 lb	95Kg	240 lb	109Kg

NOTE: Usable volume of catch pan is 0.4 ft³ for CDC-15 through CDC-30 and 1.0 ft³ for CDC-40

*Also available with 6", 8", 10" and 12" inlet/outlet

Dimensions – Drum Dump Model

(Elevated frame, dump valve and discharge sock that will fit the top of a 30 gallon customer supplied drum or for use with 55 gal. drum CCD-55 below. Other specifications same as above.)

Part Number	CDC-15D		CDC-20D		CDC-25D		CDC-30D		CDC-40D	
Height	108.4"	275 cm	108.4"	275 cm	111.6"	283 cm	111.6"	283 cm	127.4"	324 cm
Base L x W	36"	92 cm	36"	92 cm	36"	92 cm	36"	92 cm	36"	92 cm
Shipping Wgt.	300 lb	136Kg	305 lb	137Kg	440 lb	200Kg	450 lb	205Kg	550 lb	250Kg

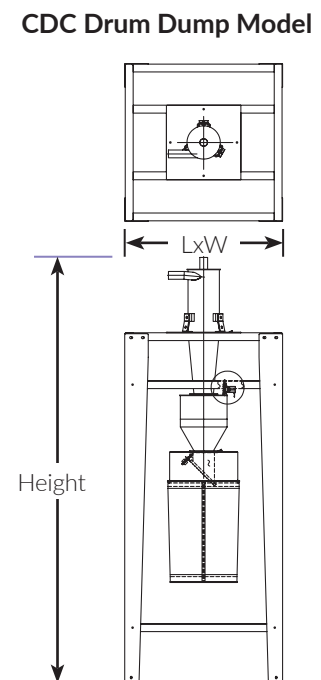
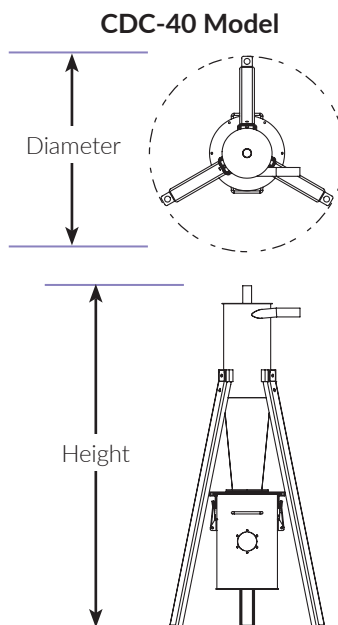
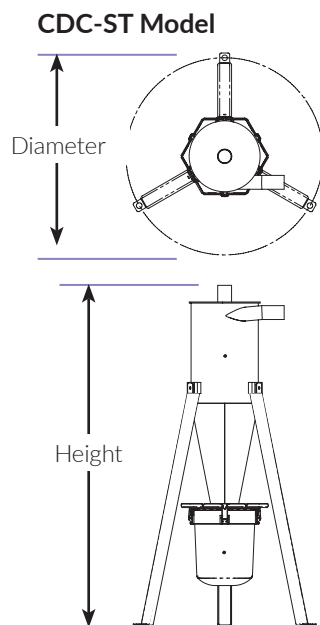

Options: (Separate line item on order and shipped separately)

Alternate Voltage: 115 VAC in lieu 24 VDC for solenoid valve on CDC-D models.

Accessories: (Separate line item on order and shipped separately)

Cartridge Filter Kit: includes wall mount Donaldson filter module, 10 ft of flex hose and 2 hose clamps. (Customer installed between pump and cyclone dust collector.)

Cyclone Collection Drum – 55 gallon



Wall Mount Cartridge Filter