



Closed Loop Conveying Accessories

5
YEAR
warranty

DSV - Discharge Selection Valve with Relief for Dry Air Conveying

- › Requires a separate relief vent in a closed system.
- › Includes 3-bolt coupler and pump adapter fitting.
- › For use with either VRB or VPDB pumps.
- › Control voltage : 115 VAC or 24 VDC

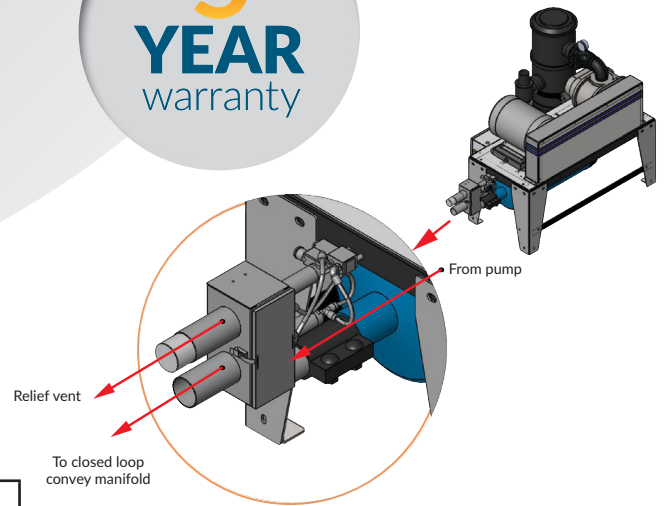

Pump inlet diameter in/mm	1.5/40	2.0/50	2.5/65	3.0/75	4.0/100

Closed loop conveying configuration illustrating use of discharge selection valve with relief vent.

Closed loop conveying system air illustration

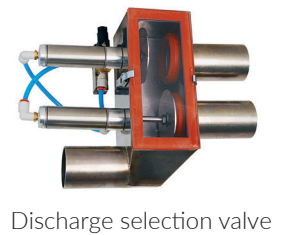
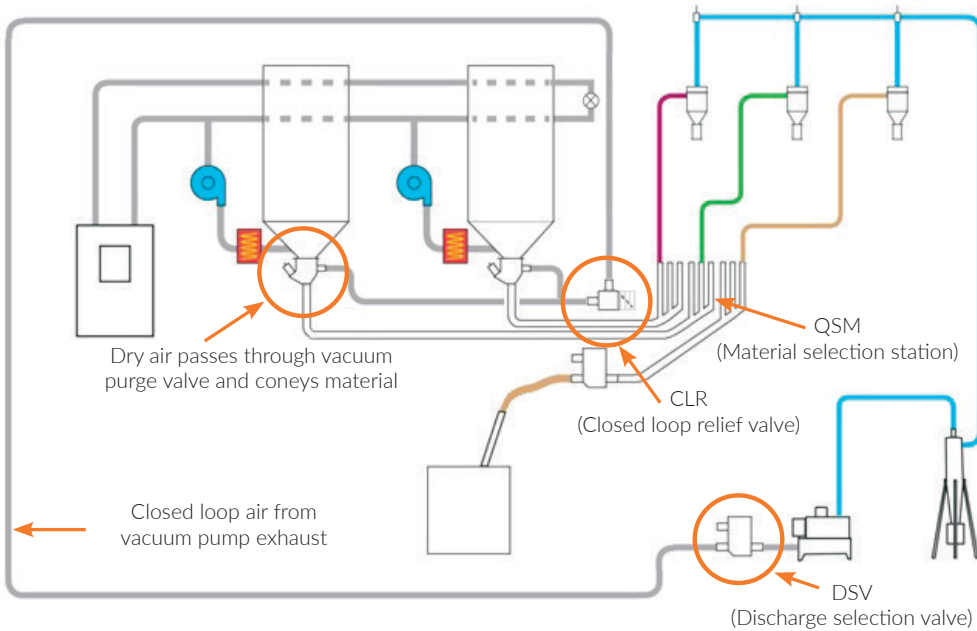

CLR - Closed Loop Relief Vent:

Provides pressure relief in a closed loop conveying system.

- › Install near take-off devices in a closed loop system.
- › Install one per row of take-offs that share a common closed loop manifold.

Must specify outlet connection stub diameter of 1.5", 2", 2.5", 3" or 4"

Inlet diameter in/mm	1.5/40	2.0/50	2.5/65	3.0/75	4.0/100



CLR closed loop valve with relief vent

CLR orientation on CDA (Central Drying Assembly)

