

INSTRUCTION MANUAL NPC-STD Series Puller-Cutter



© NOVATEC, INC 2017 All Rights Reserved

Instruction Manual NPC-STD OCT 30 2017



Novatec, Inc. 222 E. Thomas Ave. Baltimore, MD 21225 | www.novatec.com

Phone: 410-789-4811
Toll Free: 800-938-6682
Main Fax: 410-789-4638

Parts Email: parts@novatec.com
Service Email: service@novatec.com
Sales Email: sales@novatec.com

Please record the following information, which is specific to this piece of equipment, in the space provided. Our Parts/Service Department will need these numbers to properly respond to any of your requests.

Instruction Manual: NPC-STD IM 31 OCT 2017
<u>Model #:</u> _____
<u>Serial #</u> _____

DISCLAIMER: NOVATEC, Inc. shall not be liable for errors contained in this Instruction Manual nor for misinterpretation of information contained herein. NOVATEC shall not, in any event, be held liable for any special, indirect or consequential damages in connection with performance or use of this information.

Table of Contents

1.0 PURPOSE OF THIS MANUAL..... 2

1.1 Explanation of Symbols.....3

2.0 SAFETY PRECAUTIONS AND WARNINGS 3

2.1 Safe Access to Guarded Blade Area.....3

3.0 GENERAL DESCRIPTION 4

3.1 The Control4

3.2 Puller5

3.3 Cutter5

5.0 FEATURES..... 10

6.0 TYPICAL APPLICATIONS 11

7.0 INSTALLATION..... 11

7.1 Mechanical Installation 11

7.2 Electrical Installation..... 14

8.0 PLC OVERVIEW 15

8.1 General 15

8.2 Startup and Power Loss 16

9.0 PLC ICONS..... 16

10.0 LOGIN, PASSWORD LEVELS & ENTERING NUMERIC VALUES 18

11.0 INITIAL STARTUP 19

12.0 SETUP SCREENS – MPC -CUTTER 20

12.1 Cutter Setup Page 1 (setup level authorization).....20

12.2 -CUTTER SETUP PAGE 2..... 22

12.4 Servo Setup Page24

12.5 Batch Counter Screens26

13.0 SETUP PAGES - NPC-STD -PULLER..... 28

13.1 Saving, Selecting and Editing Recipes.....29

13.2 -Puller Setup Page 130

13.3 -Puller Setup Page 231

13.4 NPC-STD -Puller Setup.....33

14.0 PULLER RECIPE MANAGEMENT 34

14.1 Saving Recipe From Production Run (Quick Ops)34

14.2 Editing An Existing Recipe35

14.3 Editing A Current Recipe.....35

15.0 FOOTAGE COUNTER PAGE36

16.0 SYSTEM DIAGNOSTICS SCREENS.....37

17.0 ALARM SCREENS.....40

18.0 -PULLER OPERATION 43

19.0 -PULLER MAINTENANCE 44

At Startup44

Every Belt Change44

Daily44

20.0 CUTTER MAINTENANCE..... 45

At Startup45

Every bushing or blade change.....45

Daily45

Every 3 Months45

21.0 WARRANTY – NOVATEC, INC. - Effective Date 21 Jan 201646

1.0 PURPOSE OF THIS MANUAL

This manual describes the installation and operation of the NOVATEC NPC-STD Series Puller-Cutter. Before installing this product, please read this guide and any additional guides associated with the system’s auxiliary equipment.

1.1 Explanation of Symbols

This manual includes both general and task-specific safety precautions. These precautions are highlighted in the manual by the following categories:



WARNING: This symbol identifies situations that are potentially hazardous to personnel or equipment.

NOTE

Highlights information provided in text or procedures. This information may or may not be related to safety.

2.0 SAFETY PRECAUTIONS AND WARNINGS

These operating instructions must be read, understood, and implemented by all personnel responsible for this system.

- ❑ All mechanical and electrical work must be performed by qualified personnel only.
- ❑ NEVER disable or remove safety features. Doing so can result in severe injury.
- ❑ Always disconnect power before servicing.
- ❑ Refer to the machine serial number nameplate and drawings supplied with this system for actual power requirements.
- ❑ Be sure to install the equipment with the proper electrical connections according to all national and local regulations.
- ❑ Electric power supply should be through a separate disconnect switch with properly sized overload/fuse protection.
- ❑ The customer is required to operate the equipment with all safety features in proper working condition.
- ❑ NOVATEC shall provide no further guarantee for function and safety in the event of unauthorized modifications.

2.1 Safe Access to Guarded Blade Area

It is safe to access the guarded blade area when the power is on. NOVATEC Cutters use a servo that has built in safety. It can execute a Safe Stop on E-Stop and has a Safe Torque Off which is executed within 0.5 seconds of E-Stop. It also is monitoring itself for Safe Standstill which is interlocked to the guard lock. With the addition of redundant

safety relays, motor contactor and guard interlock, the system can exceed SIL-3, PL-d safety requirements for a Cat3 safety hazard.

NOTE: Additional guarding may be required where the product enters and exits the bushing.

NOTE: The Safety Circuit Must Be Tested on 90 Hour Intervals

To meet the requirements for a Cat3 safety system, the safety circuit must be tested at regular intervals to insure that it is functioning properly. When the system is first powered on, the power must be engaged and then the E-Stop activated to ensure that it is functioning. After 90 hours of continuous operation a Warning Message will appear instructing the operator to perform the safety verification test which involves pressing the E-Stop and the resetting the circuit. Production can continue while the message is present but arrangements should be made to perform the test as soon as possible.

Even though there is no power to the blade when the system is E-Stopped, there is still the hazard of the sharp blade. Care should always be taken when working in this area. Please contact Novatec if there are any questions or concerns.

3.0 GENERAL DESCRIPTION

The NOVATEC NPC-STD Series Puller-Cutter utilizes an NPC-STD puller to pull extruded products through sizing and/or cooling tanks and feed them to a "C" series cutter for extremely accurate cuts. They are mounted on a common base. The puller control line speed through a precision servo connected to a right-angle gearbox that drives a dual serpentine belt. Poly-V drive and driven pulleys ensure consistent pulling traction. This is achieved by precisely regulating the lower traction belt and using a synchronous serpentine belt to drive the upper traction belt. Multi-V drive pulleys provide excellent product tracking capabilities. Several model sizes are available. Belts are either 4" x 30" or 6' x 30" while the cutter can cut a cross section of either 2", 3" or 4". The cutter is also servo-motor driven for uniform accuracy. The cutter can be easily moved on guides so a different cutting method can be utilized, if required.

1. The extrusion enters the puller from the upstream side of the puller.
2. Guide rollers position the extrusion entering the traction belts.
3. The clamping force is set manually using a hand wheel
4. The clamping force can be locked in place using a clamp collar
5. Upper and lower traction belts move the extrusion through the puller
6. Pulled material is fed to the cutter.
7. The cutter can be moved forward/backward by loosening a clamp and sliding the cutter head on rails.
8. The cutter can be moved side-to-side by loosening a second clamp and sliding the cutter head on rails.
9. If the cutter is not to be used, it can be moved backwards, away from the material being fed by the puller.

3.1 The Control

A single, Siemens 7" high resolution color touch screen PLC with connectivity controls the puller and cutter. The control can be switched for use with the puller or the cutter with the touch of a button. The control includes 4 levels of logon security as well as recipe screens for both the puller and cutter. Some configurations allow for separate controls for the puller and cutter.

3.2 Puller

Each traction assembly is mounted to rigid and accurate aluminum guides which ride vertically on round steel shafts to adjust the traction assembly position. Beams adjust individually with a hand wheel.

Each puller belt is accurately tensioned by means of a pair of air cylinders inside the traction assembly. The air cylinders are regulated and acting on the driven pulley at the in-feed end of the belt. The air cylinders are monitored with a pressure switch so that tension is assured before operation of the drive motors. A bleed valve allows relief of the tension cylinders for belt changes.

Wrap-around adjustable guarding prevents access to in-running (upstream) NIP points when properly adjusted.

Belt Width X Length

- 10.16 cm wide x 76.2 cm [4" x 30"]
- 15.24 cm wide x 76.2 cm [6" x 30"]

Max feed opening: 4" for 4" wide belts, 6" for 6" wide belts

Total horsepower: 2.2 kW [3 hp] - all NPS machines

Drive Type: Single Servo with synchronous serpentine drive of upper traction assembly

Gear Ratio/Belt Speeds (full torque range):

<u>Gear Ratio</u>	<u>Speed - meters/minute</u>	<u>Speed – Feet/Minute</u>	<u>Approximate Pull Force lb / Kg</u>
7.5:1	1.67-129.5	5.5-425	208 / 94.4
10:1	1.22-99	4.0-325	278 / 126.1
15:1	0.82-67	2.7-220	417 / 189.2
20:1	0.61-50.3	2.0-165	556 / 252.2
30:1	0.463-33.5	1.4-110	580 / 263.1

3.3 Cutter

The NOVATEC, C Series Rotary Knife Cutter offers high versatility to cut a wide range of profiles. It is able to cut small profiles at high speeds and large profiles at lower speeds. Extrudate is fed into the cutter from upstream, typically by a puller. Two cutter bushings

on either side of the knife, guide the extrudate through the cutter. A rotary knife is mounted to a 12” diameter cutter head and driven by a servo motor through a gear reducer. This knife cuts material that is supported between the bushings. The knife is positioned at a home position until the cut motion begins. The knife then rotates through a cutting lubricant/chip collection reservoir, through a felt blade wipe to clean the blade, and then through the bushings again to make another cut. The cut extrudate continues to move through the bushing where it is either collected or is conveyed further downstream by an optional conveyor.

Two cutting modes are available: ON-DEMAND cutting mode and CONTINUOUS cutting mode. Within these two major modes of operation, a wide range of parameters may be adjusted for consistent, repeatable, and precise results.

- ON-DEMAND cutting mode allows 250 cuts per minute. The blade does not continuously rotate, but instead starts and stops as needed.
- CONTINUOUS cutting mode allows up to 750 cuts per minute by continuously rotating the cutter head at a speed sufficient to cut the desired length at the measured line speed.

Model Number	C-2	C-3	C-4
Bushing Diameter	2.25 in.	3.25 in.	4.25 in.
Maximum Profile	2 in. Dia.	3 in. Dia.	4 in. Dia.
Power - HP	5	5	11.8
Max Continuous Cuts (1 Blade)	800 CPM*	800 CPM*	750 CPM*
Maximum On-Demand Cuts (1 Blade)	300 CPM @ 600 RPM	300 CPM @ 600 RPM	200 CPM @ 600 RPM
Maximum On-Demand Blade RPM	1000**	1000**	900**
Maximum Peak Torque (in./lbs.)	1130	1130	3720
Blade Mount	12 in. Stainless Steel Cutter Head		

* Higher rates may be available for certain applications with specific cutter. Single and multiple blade configuration.

**See charts below for actual CPM @ Maximum RPM.

3.4 Overall Dimensions

NPC-STD 6x30

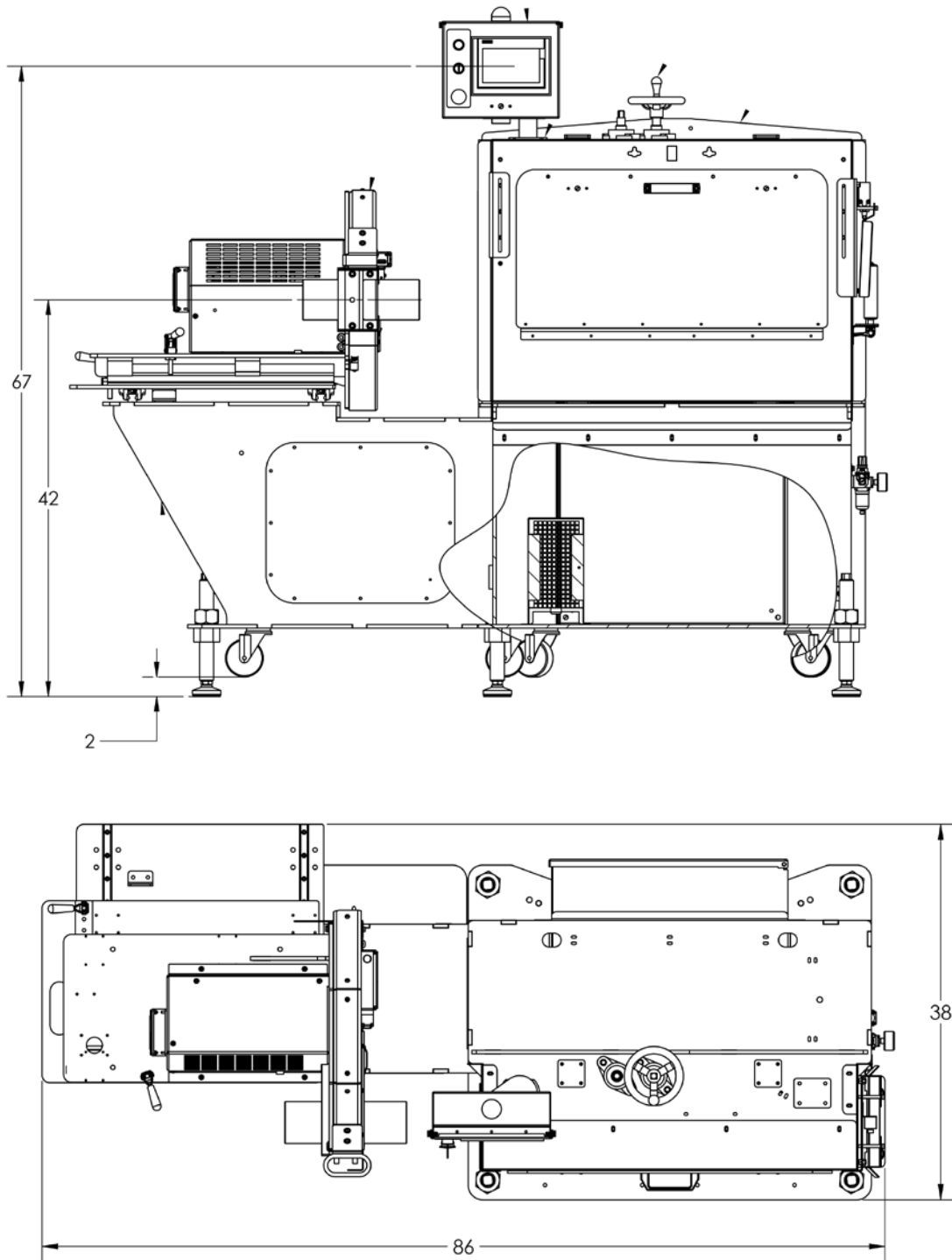

NPC-STD 4x30

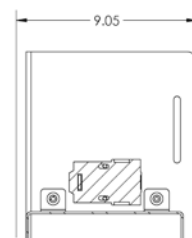
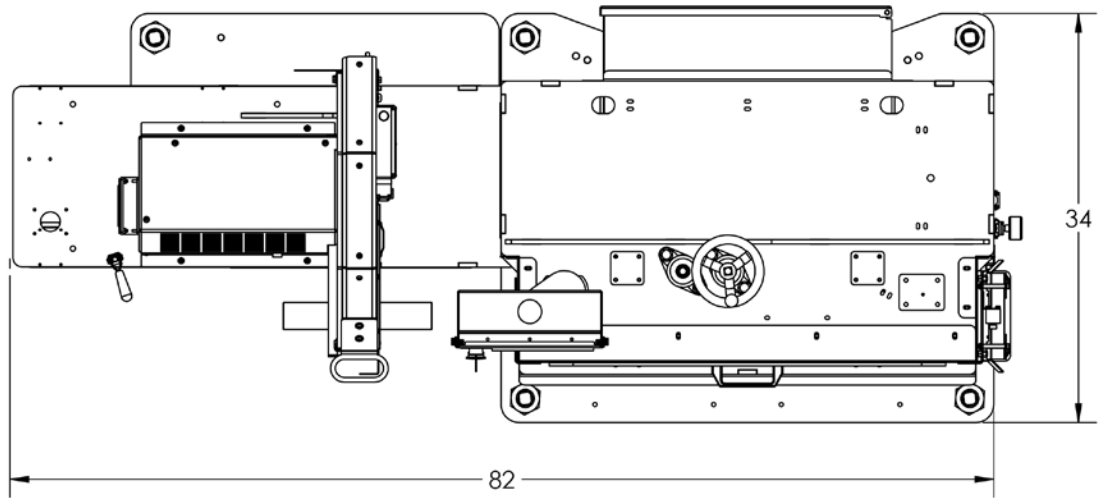
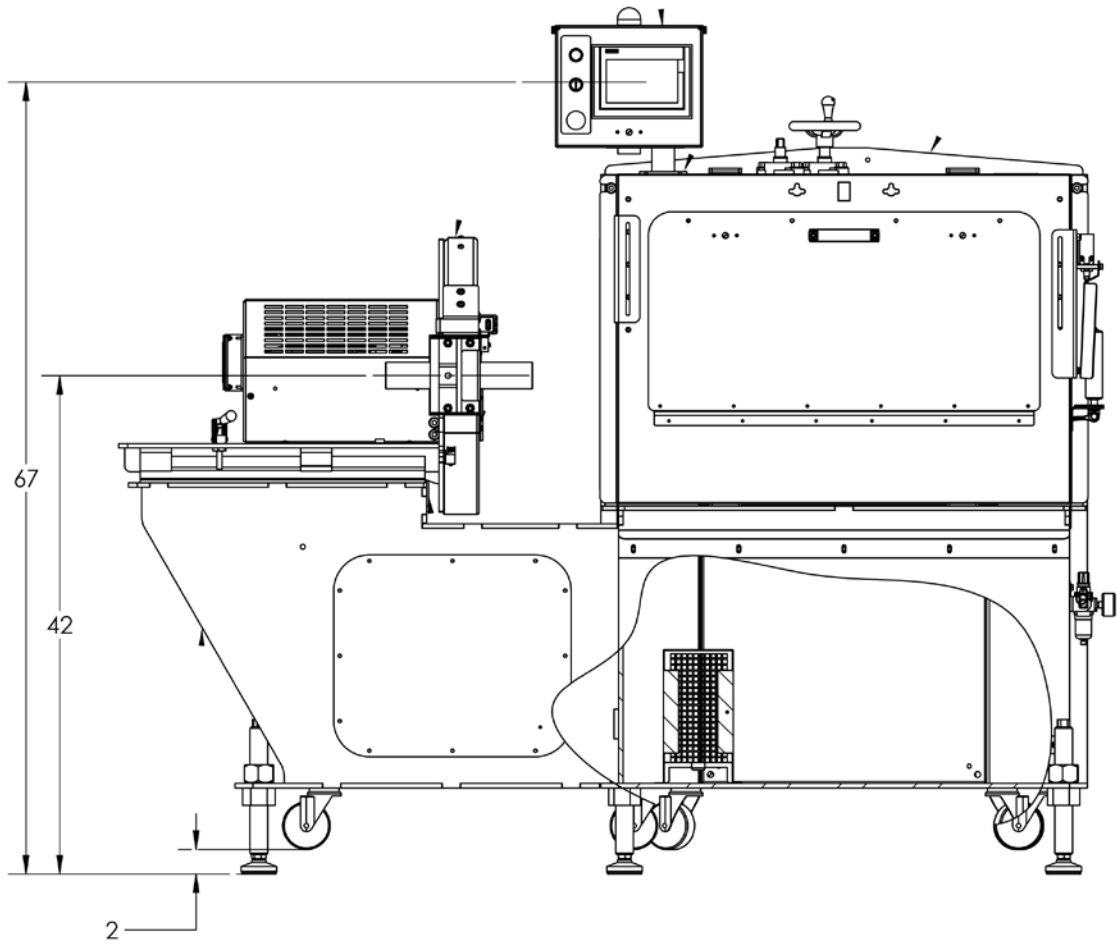

Guard Tunnel- Optional

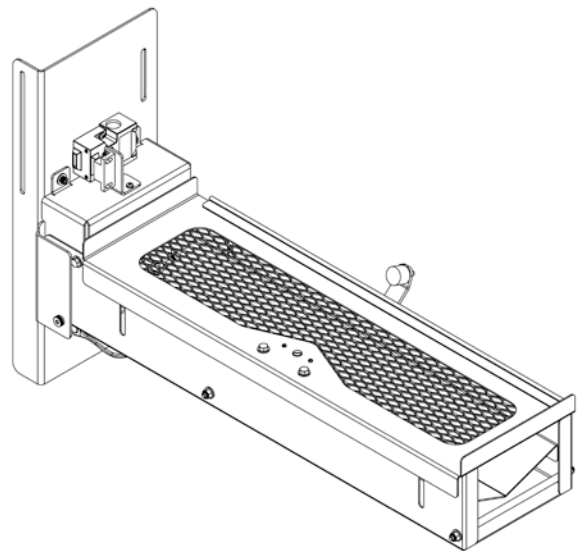

5.0 FEATURES

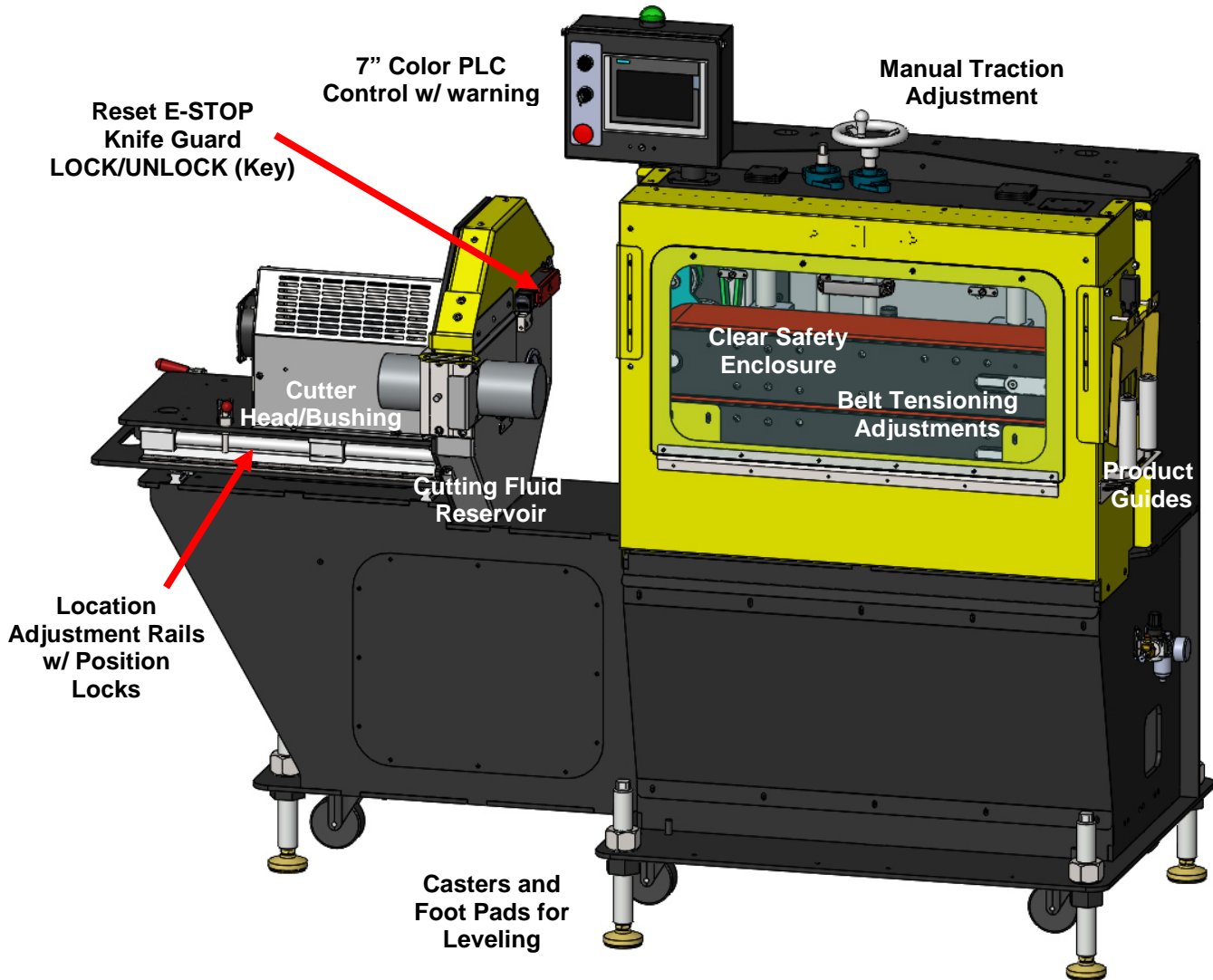

6.0 TYPICAL APPLICATIONS

NOVATEC NPC-STD series puller-cutter pulls extrudate from a functional extrusion process or from coils. The NPC-STD series puller belt width determines the maximum profile size that can be conveyed. The NPC-STD cutter can cut extrudate with a cross section of up to 3". The outer surface (cover) of belt material is important to process consistency. Soft belt cover materials have the best pulling capability and are less prone to slipping, however, they are more prone to tearing. Poly V belts are standard on the NPC-STD family of machines and provide better power transmission and tracking as compared with toothed timing belts and flat belts.

7.0 INSTALLATION

1. Carefully unpack the puller/cutter and any other components delivered with it. Check all packaging for loose parts, documentation, and other included items. Carefully inspect the unit. Ensure that no wires, bolts, screws, terminals, or other connections have come loose during shipping. Check to ensure that all moving parts are not obstructed by debris or excess packing material.
2. You may require the following tools to complete the installation:
 - a. 16" or 18" adjustable wrench
 - b. Metric and Imperial hex wrenches
3. All national and local electrical, building, and safety codes need to be followed. Proper grounding of all equipment is important. Check the electrical wiring schematic for wiring numbers and details. The following paragraphs describe installation of typical system components. Some of them are optional and may not be required for your system.

CAUTION: *All machines must be grounded to prevent "shocks" from static electricity that is generated by some materials as they are moved. This is an extremely important step.*



All electronics are susceptible (to varying degrees) to electrostatic damage and, although as much protection as possible has been designed into the system; this cannot completely eliminate upsets due to electrostatic voltage being accidentally introduced into the electronic circuitry.

7.1 Mechanical Installation

1. **Determine the position of the puller.** The puller should be positioned at the exit end of the cooling tank or coil.

WARNING: Pullers are unidirectional and should only be placed in the product flow direction for which they are designed. Pullers are designed to pull in the direction from the non-motor end toward the motor end of the machine.

Right to left material flow is the standard machine configuration. Machines designed for right to left material flow will have motors on the left when facing the machine's touch screen control when properly oriented. The non-motor end of the puller should be closer to the extruder than the motor end of the machine when properly oriented.

Observe all compliance and legal requirements for safety and guarding relating to the machinery installation. Allow at least 300 – 600 mm (12 to 24 inches) between the downstream end of the sizing tank and the input end of the puller so the tank/sizing table can be moved away from the extruder for startup and maintenance. Allow at least 925 mm (36 inches) of clearance in front and back of the puller/cutter for user and maintenance access.

The puller should be as close as possible to the cutter for flexible products.

2. **Once the general position has been determined, carefully align the puller with the extrusion line.** It is easiest to adjust the position on the floor before adjusting to the proper height.
3. **Measure centerline height of extruded product centerline.** Use a laser or liquid level to ensure all equipment is aligned to this height.
4. **Align the puller with the centerline height of this equipment.**

To adjust the centerline height of the puller, adjust each foot pad at the corners of the base of the puller with a 400-460 mm (16" or 18") adjustable wrench. Ensure that the puller is level. The bottom of the puller base plate should be positioned 110 mm (4-1/4") from the floor for a 1067 mm (42") centerline height.

! CAUTION: Never operate puller/cutter while on casters. Always set Foot Pads. Puller MUST be Securely Anchored to Floor Before Operation.

5. **Ensure that the centerline height of the machine allows proper vertical travel for the upper traction assembly.**
6. **Install puller belt suitable to application.**

Ensure the recommended belt is installed before start-up. Refer to the “Replacing Belts” section of instruction manual if required. Typically, soft belts are used for thinner walled more fragile parts and hard belts are used for parts that are less prone to deformation due to greater compression force. 40 or 55 durometer belts are typically used for general use where machines are not dedicated to particular extrudate geometry. 55 durometer belts are offered as standard for NPS pullers.

7. Guarding and product guides

Fully enclosed see-through guarding is provided for pullers. It is designed to prevent access to the in-running nip point hazard zones.

CAUTION: Never use equipment without properly installed guarding which is appropriate to its location of use and compliant with local law and compliance guidelines.

Adjust the belt puller guide roller or product guide so that the product is positioned in the center of the belt.

8. Cutting Fluid Reservoir

The cutter is supplied with a lubrication reservoir. The blade reservoir should be filled to a point where the blade will be fully submerged as it passes through the reservoir so that proper lubrication is supplied to the blade wipe and bushing.

9. Cutter Blades

When installing the cutter blades, great care should be taken to avoid being cut. Use cut-resistant gloves to avoid injury. Wait until the knife assembly fully stops before opening the inspection door.

Ensure the cutter has stopped rotating; rotate the key switch clockwise (to 2 o'clock) and wait 5 seconds for the door to unlock; open the bushing guard (yellow cover).

Rotate the cutter head to a point where the hole in the Cutter head, lines up with a hole in the cutter enclosure. Insert an Allen wrench through the two holes to hold the cutter head in place. This avoids the possibility that the cutter head will move while loosening/tightening bolts. Remove the bolts holding the counter-balance or the old blade(s), remove counter balance or the old blade(s), and fasten new blade(s) in the same way the old blade was attached.

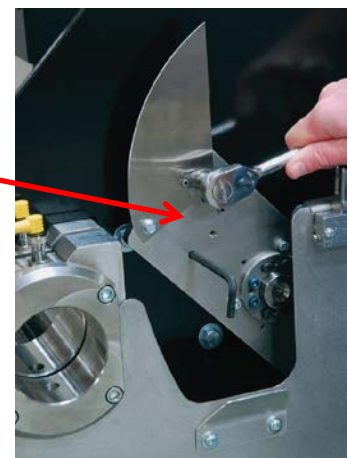

Check that the new blade fully extends through the bushing so that the entire product is cut. **Tighten the knife-securing hardware to 140 inch-pounds of torque.**

Always check the blade(s) to bushing clearance after installing a new blade(s) by rotating the cutter head manually and inspecting the gap between each of the bushings and the blade(s). Ensure that the blade(s) moves freely through the bushings and that the bushings are properly secured before re-powering the machine.



NOTE: Counter-balance should be removed on end where blade is installed.

NOTE: When a single blade is installed, it must be installed on same end of cutter head as the

NOTE: Counter-balance weight, opposite the blade, must remain bolted in place if only one blade is used.

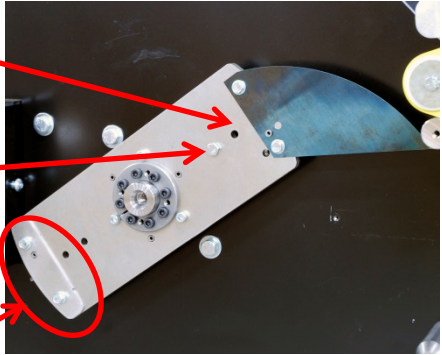

10. The Bushing

Ensure the cutter has stopped rotating; rotate the key switch clockwise to “UNLOCK” (2 o’clock) and waiting 15 seconds for the door to unlock before opening the bushing guard (yellow cover). Loosen the rectangular bushing by loosening the 12mm socket head set screw located on the top of each cylindrical bushing holder. Test the location of the bushings for accuracy by retightening the bushing holder socket head set screw and manually rotating the cutter head to ensure that the blade passes through the two bushings. When satisfied with the fit, fully retighten the bushing holder, inspect the blade clearance an additional time and make sure the cutter head can rotate a full revolution while clearing the bushings. During initial set up, the cylindrical bushing holders should be adjusted relative to one another by loosening the socket head cap screws on the front of the machine that clamp the bushing holders in place. This adjustment ensures the rectangular bushing holders are rotationally aligned about the axis of the cylinder.

7.2 Electrical Installation

Always disconnect and lock out the main power supply before wiring power and control cables between the NPC-STD series puller-cutter controller and the external devices. Refer to the wiring diagram and general arrangement drawings supplied with this system before making electrical connections.

- ❑ Use shielded cable for communications wiring.
- ❑ Keep communication cables and control wiring as far as possible from high voltage equipment. If you must run cable across power lines, run the cable at right angles to the line.
- ❑ Ensure the equipment grounding is properly connected. Shielded cable should be grounded at one end only and is typically grounded in the main I/O enclosure.

WARNING: Do not install communication cable where it will come into contact with any buildup of electrical charge!



It may be tempting to run the wire next to the material conveying lines, but a substantial buildup of electrical charge can and will occur, especially with certain types of plastic resins and, if the conveying lines are not grounded, they can arc to the cable disrupting communications and/or possibly causing damage.

Open the puller/cutter electrical enclosure and insert the main power through a knockout in the wall of the enclosure. Connect the power wire as indicated on the included wiring diagram. Check that all terminal screws are secure. Close electrical enclosure.

Before testing the machine, confirm that the placement and wiring of the puller/cutter conforms to all applicable national and local regulations. When ready, turn on the main disconnect. Make sure that the E-Stop button is in the "OUT" position. Press the reset button.

All national and local electrical, building, and safety codes need to be followed. Proper grounding of all equipment is important. Check the electrical wiring schematic for wiring numbers and details. The following paragraphs describe installation of typical system components. Some of them are optional and may not be required for your system.



CAUTION: All machines must be grounded to prevent "shocks" from static electricity that is generated by some materials as they are moved. This is an extremely important step.

All electronics are susceptible (to varying degrees) to electrostatic damage and, although as much protection as possible has been designed into the system; this cannot completely eliminate upsets due to electrostatic voltage being accidentally introduced into the electronic circuitry.

8.0 PLC OVERVIEW

8.1 General

The NOVATEC NPC-STD Series puller-cutter use a Siemens PLC controller to control all functions including recipe management, user settings, user display and process monitoring. A high resolution touch screen provides the human to machine interface to the PLC.

8.2 Startup and Power Loss

When power is first applied to the NPC-STD following a power loss, the Puller will return to the Home screen. The last active recipe will remain loaded and can be accessed by pressing the picture of the machine or the button with the puller belts.

9.0 PLC ICONS

The icons used on the touch screen of the PLC are meant to be self-explanatory but the following explanations may be helpful. Touching them will result in the action described.

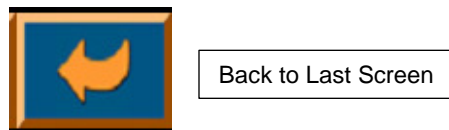
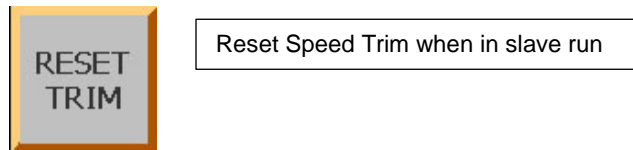
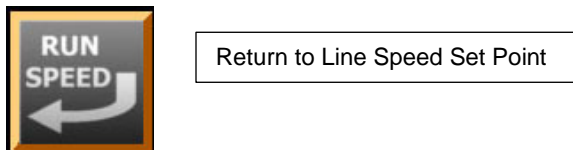



Start/Pause Footage Counter for This Run



Start/Pause Footage Counter for Combined Runs



Shortcut to dedicated Footage Counters screen



To System Diagnostics Screen



Backup and Restore Setup Parameters to/from the SD card



To User Management Screen



Terminate HMI Application & Open System Control Panel

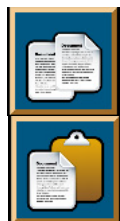

Copy & Paste (Edit Recipe Screen)



Activate, Acknowledge or Commit Change



Cancel / Change

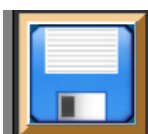

Saves Change to Recipe



To Setup 1 Screen



Smart Access Visibility Enabled



Smart Server Enabled



Opens Dashboard

10.0 LOGIN, PASSWORD LEVELS & ENTERING NUMERIC VALUES

These procedures are common to all NOVATEC Pullers and Cutters.

Press  in upper RH corner of the screen.

An alpha/numeric screen will appear.

NOTE: If the proper level of password protection has not been entered prior to attempting changes, the alpha/numeric password entry keypad will appear, prompting the user to input the proper user name and password before changes can be made.



User name and Password factory defaults:

- level1 : 1111 (Operator)
- level2 : 2222 (Production Supervisor)
- level3 : 3333 (Maintenance)
- setup : 4444 (Factory Presets – Setup Group)

Enter 4444 then touch to return to the HOME Screen.

You may want to create your own passwords for various levels of access.

Press on the HOME screen, then to access USERS MANAGEMENT SCREEN shown below.

USERS MANAGEMENT			
User	Password	Group	Logoff time
Level1	*****	Users	0
Level2	*****	Production	5
Level3	*****	Maintenance	5
PLC User	*****	Unauthoriz...	5
Setup	*****	Setup group	5

To replace Level 1, 2, or 3 with an individual's name, double-tap that button and enter the name on the alpha/numeric screen that will appear. A maximum of 4 and a maximum of 9 letters can be used. Touch the arrow after your entry to return to the User Management screen.

To set User Passwords, double tap in the password block and you will be prompted to enter the new password twice. **NOTE:** Whenever the user name is changed, logoff and logon with the new user name is required for the system to backup the new user name.

ENTERING NUMERIC VALUES: Instead of an alpha/numeric screen, a numeric screen will appear. Enter desired value and press

11.0 INITIAL STARTUP

Please follow ALL installation and safety procedures described in this instruction manual.

Turn the Main Power Disconnect to "ON" (12 O'clock) position. The red light on top of the control

panel will illuminate. A series of safety verification screens will appear to guide you through the safety procedures. Follow instructions on screens.

NOTE: Procedures that are already completed will not appear.

The light blinks orange during the Homing Sequence, then green when complete. CUTTER Quick Ops screen will appear.

12.0 SETUP SCREENS – MPC -CUTTER



Proceed with setting parameters **UNLESS** you are ONLY using the PULLER (i.e. running direct to a spooler.) in that case, press CUTTER QUICK OPS at top of screen. ▲ 1
 PULLER QUICK OPS screen will appear (see PULLER SETUP)

Each cutter is pre-programmed with certain Setup parameters. You can see those settings and change them in the Quick Ops Screen. Press button ▲ 2 to SET LENGTH. A numeric screen will appear. Enter value and press ▲ 4 to return to Quick Ops Screen.

Enter blade speed ▲ 3 in same manner based on your experience with the product being cut. The cutter automatically goes into ON DEMAND or CONTINUOUS MODE ▲ 4 based on the Input from the encoder. Press TEST CUT ▲ 5 to cut a single piece at a time or press CUT SCRAP to cut multiple pieces until you are satisfied with the cut quality and length.

Press the CUT PRODUCT ▲ 6 button when ready to start production. Level 1 personnel may also start the BOX COUNT and BOX FILL ▲ 7 but BOX COUNT and BOX FILL can only be set by Level2 personnel.

Check the time and date ▲ 8. If not correct, press the time or date and a numeric screen will appear. Enter time as xx:xx:xx (24 hour clock) and date as xx/xx/xx.

This is important so error messages will have the correct time and date stamp.

▲ 9 Saving, Selecting and Editing recipes is same for NCP Cutter as for NCP Puller. (See page 31)

12.1 -Cutter Setup Page 1 (setup level authorization)

The main purpose of this section is to demonstrate the degree of control you have over the NPC-STD cutter parameters.

ALL PARAMETERS ARE PRE-SET AT THE FACTORY AND ANY CHANGE REQUIRES "SETUP" AUTHORIZATION.

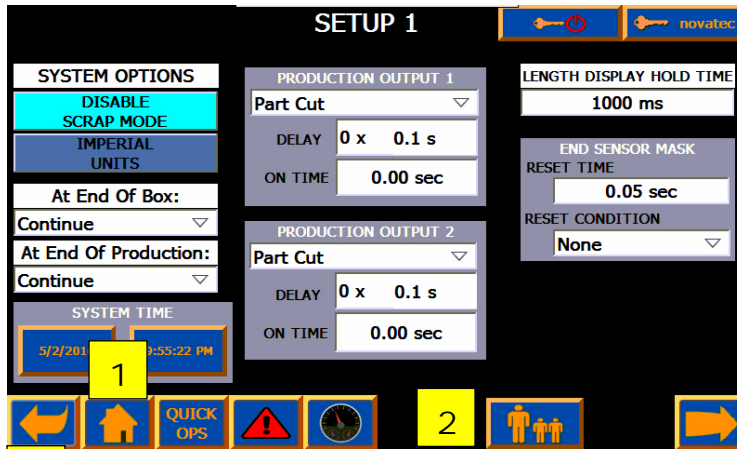

1

To change Time and/or Date:
 Press the appropriate Button and enter the date as: xx/xx/xxxx or the time as xx:xx:xx (24 hour clock).

Press to return to the SETUP 1 screen.

2

Press to access **User Configuration** to change the usernames, passwords and auto-logoff times. See 13.3 on page 23. You can assign specific personnel or personnel levels for each of the access levels.

All items on this page are accessible to be changes by a level 2 or higher user. **The arrow** 3 to go to the second setup page will only appear for level 3 and higher users.

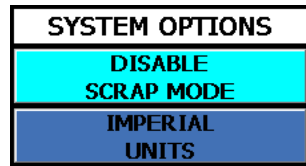

SYSTEM OPTIONS

Enable/Disable Scrap Mode – Press this button to Enable Scrap Mode.

Imperial/Metric Units – Press this button to toggle the display units between English and Metric.

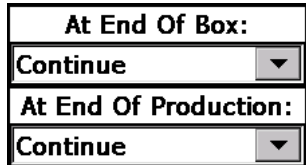

AT END OF BOX

Count Triggers - Triggers change in machine operation when part count reaches end of box and production. Is the same function as on the Counter Screen.

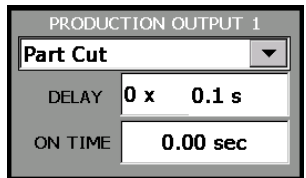

PRODUCTION OUTPUTS 1

- There are two dry contact outputs supplied in the control panel. Q0.0 corresponds to Production Output 2 and Q0.1 corresponds to Production Output 1. They can be configured to trigger on many events including Part Cut, Box Change, Production Done, Running, Run Product, Run Scrap, Stopped or Faulted. The signal can be delayed and held for a user settable amount of time. They

are not high speed response signals. There is a typical lag of about 30 ms with an error of +/-10 ms. If a higher speed, more precise output is required, option NC8016 shown on schematics is required. Sales must be contacted to ensure the proper form of the output device.



LENGTH DISPLAY HOLD TIME

- This value determines how long the display will show the last cut length before showing the accumulated length of the next part. Set it to zero to always show only the last cut length. It is recommended to be set to at least 500ms. Parts that are cut faster than 500ms may be difficult to see no matter the setting.

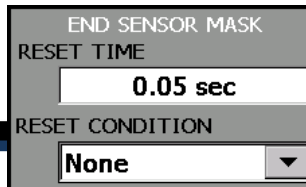

END SENSOR MASK

It is commonly required to mask the end sensor signal after activation to prevent subsequent activations. Set the timer value to prevent a

second activation until the time set has expired. Never set the value higher than the time between cuts or cuts will be missed. The mask can be can also be configured to reset on either the positive or negative going production signals or by a customer provided signal to input 1.0 on the PLC.

12.2 -Cutter Setup Page 2

This screen is used to set some of the more advanced features of the equipment. All of the items on the left column require a setup authorization. Everything else can be accessed by level 3 authorization.

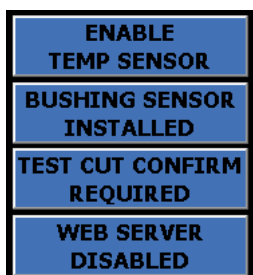
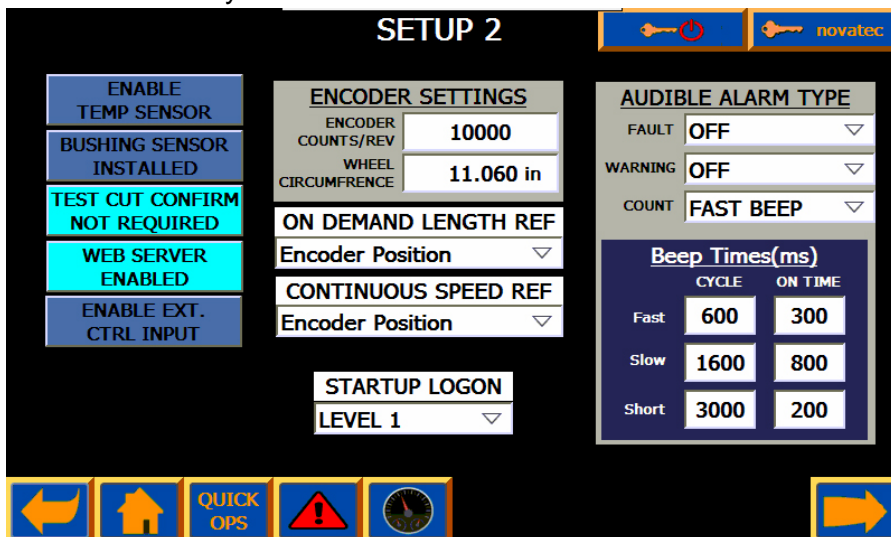

ENABLE TEMPERATURE SENSOR – This field enables the temperature display on the Quick Ops Screen. This is an optional item that must be purchased separately or the end user must install their own device.

BUSHING SENSOR INSTALLED – Press this to enable bushing sensors if they are installed.

TEST CUT CONFIRM REQUIRED - This button toggles the requirement for the popup window to confirm a test cut. To avoid accidental activation, the test cut button will require it be held for 1/2 second.

WEB SERVER ENABLED/DISABLED - Toggles the availability of the screens to be accessed from another HMI or web browser. If it is enabled without the required license installed, an annoying message will appear every few minutes.



STARTUP LOGON

All machines ship with the user login set to none as default which means the operator must log in to start the machine. The system can be set so that it is always level 1, level 2 or level 3 when it starts or is logged off. Be careful when setting it to higher levels because it may give unintended access to features which operators don't understand.

12.3 -Cutter Setup Page 3

All items on this page require setup authorization except for Exit HMI and background color.

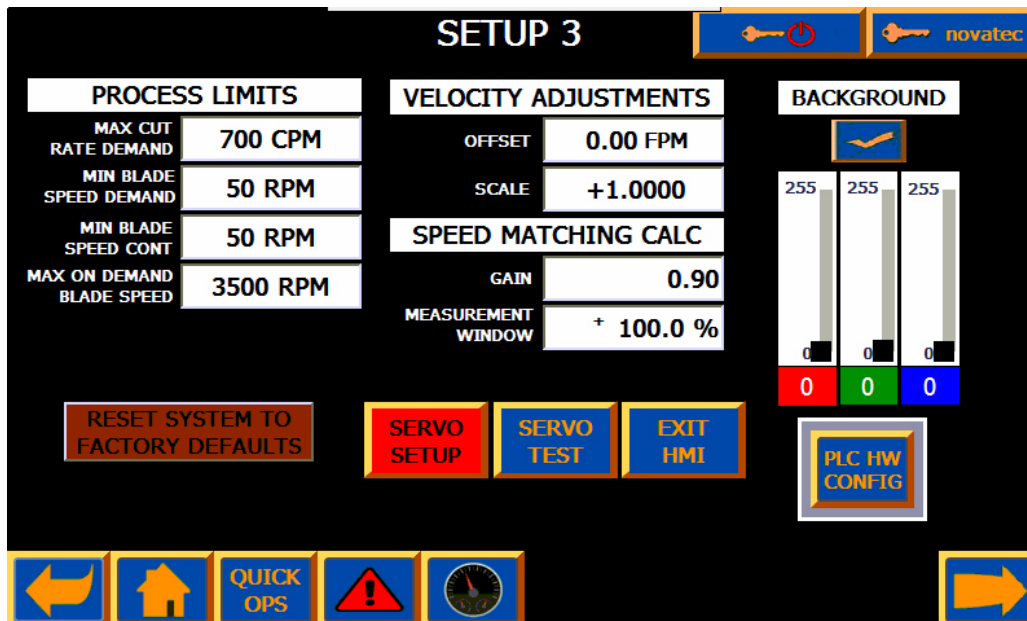

PROCESS LIMITS	
MAX CUT RATE DEMAND	200 CPM
MIN BLADE SPEED DEMAND	50 RPM
MIN BLADE SPEED CONT	100 RPM
MAX ON DEMAND BLADE SPEED	900 RPM

PROCESS LIMITS – Determine the blade speed limits and the points at which the cutter will switch between On Demand and Continuous Mode.

Max Cut Rate Demand – This determines the mum time between on Demand cuts. It also determines when the system should switch to continuous mode.

Min Blade Speed Demand – Sets the mum speed that can be entered as the On Demand blade speed on the recipe screen.

Min Blade Speed Cont – Sets the mum permissible RPM of the blade in continuous mode. Typically this is set to a value which can still give a good cut to the product.

Max On Demand Blade Speed – This sets the maximum blade speed for On Demand cutting. This will be limited by the max motor speed and is typically set by NOVATEC so that the drive does not fault when accelerating and decelerating and the overall system can handle the forces of the blade motion.

Note: It is possible to make settings where there are line speeds that cannot be handled by Max On Demand CPM or mum Continuous Mode blade speed.

The Max continuous speed is the max speed of the motor and the gear box. It is possible to run the continuous speed so fast that when it stops or transitions to On Demand Mode, the drive faults.

VELOCITY ADJUSTMENTS	
OFFSET	0.00 FPM
SCALE	+1.0000
SPEED MATCHING CALC	
GAIN	0.90
MEASUREMENT WINDOW	+ 100.0 %

VELOCITY ADJUSTMENTS - Adjusts the velocity so that the received velocity creates parts of the correct cut length

Offset – Adds the value in the offset to the value read.
Scale – Multiplies the value in the scale to the value read.

SPEED MATCHING CALC – Sets the characteristics for how the cutter responds to the speed signal when running continuous mode.

Gain - Determines how fast the cutter will respond to changes in line speed. Setting it to .99 will make it react immediately but can cause oscillation. A typical setting is between 0.5 and 0.8.

Measurement Window – This will determine what values outside the range of the set line speed will be ignored as noise. Three consecutive readings outside the window will cause the cutter to stop. Setting it to 100% effectively overrides it.

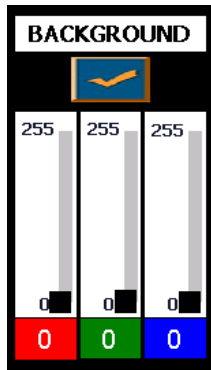

Screen BACKGROUND Color - Select the Red, Green and Blue content using the sliders or the numeric entry fields. The area around the check box will show the new background color. When the color is ok, press the checkbox to change the background colors of all the screens. Black(0,0,0) is the default background color. **Care should be taken to not use very bright colors or colors that match other fields because they will bleach out some items.**



RESET SYSTEM TO FACTORY DEFAULTS

Pressing this button will set all of the setup values to the defaults for the type of machine detected. A drop down box will appear to accept or cancel. **This should only be pressed if the setup values were altered such that the machine cannot run properly.**



SERVO SETUP – This button is for maintenance and experienced operators only. Pressing this opens the detailed setup information for the blade servo. This button will be greyed out if the system is running.



EXIT HMI

This button is for maintenance persons only. It will stop the operator interface program and return the unit to the Windows CE operating system. All control of the machine is lost until the program is restarted or power is cycled. The emergency stop will still be functional.

12.4 Servo Setup Page

This page is for maintenance and experienced operators only.

CAUTION: Great care should be used when accessing this page. Incorrect values could make the equipment unusable.

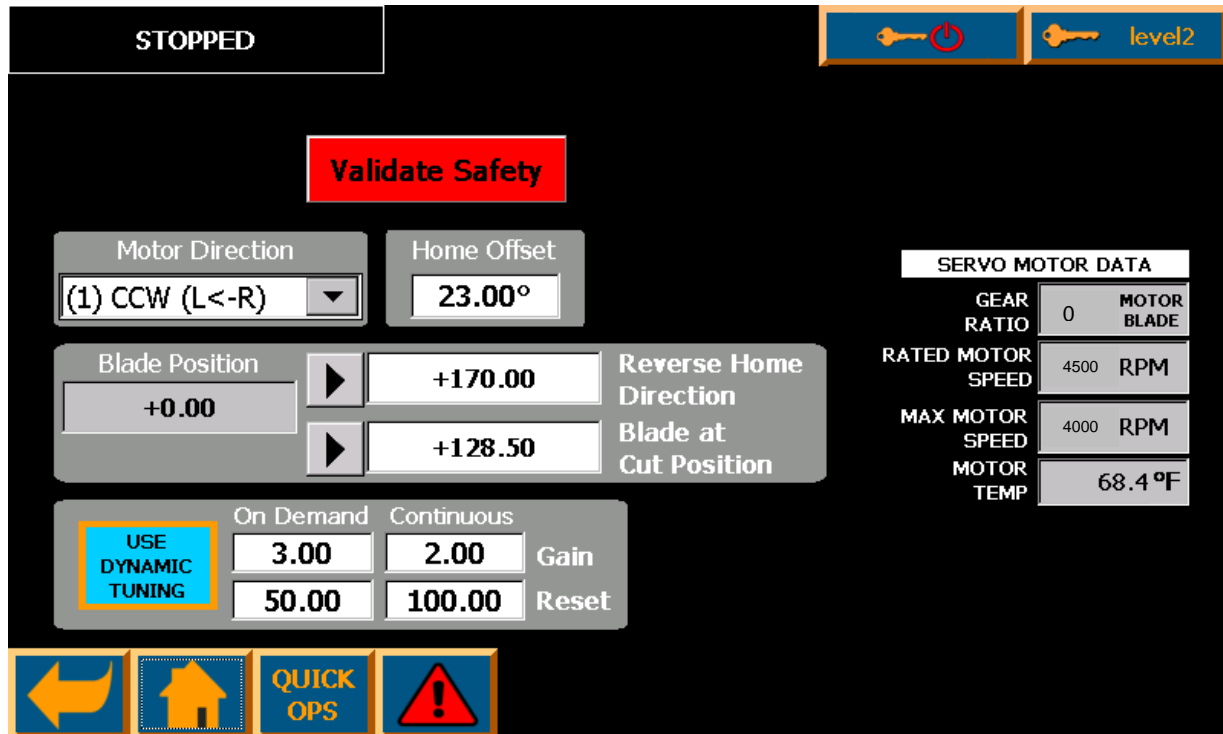

Validate Safety – This button is only used when commissioning the servo system or if a component is replaced. The procedure checks the components of the system against the safety program written and ensures that they are compatible. Because components and software can be upgraded at later dates, the test must be performed even if the component being changed is the same type. The validation components are the servo motor, encoder, power module, control unit, program and CF card. The safety license is stored on the CF card. If it is missing, an alarm warning will be displayed but the system is still operational.

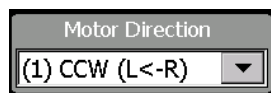

Motor Direction – The motor direction is set when the machine is first commissioned based on the hardware used. It is dependent on the machine being fed from the left side or right side.



Home Offset - When the machine is first powered up, it homes to a sensor and then moves an offset and sets this as the final home position. This is so that a machine with 2 blades will not stop with one of the blades in the cut area and to maximize the cut energy. It can set for the blade being used. To perform the home offset, enter a new offset in degrees and cycle power to the machine. This will be the new zero or home position.

Blade Position – This shows the current position of the blade in degrees relative to the home

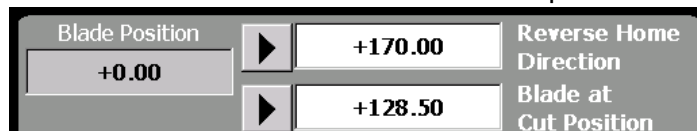

offset position. To set either of the positions to the right, move the blade to the desired position and press the arrow to save the position. A confirmation will

appear in the numeric field and you must

accept or cancel.

Reverse Home Direction – This position sets the position of the blade where it will go backwards or forwards to home. If the position is lower than this value it goes backwards to home, otherwise it goes forward to home. When homing on power up, the blade always homes in the forward direction. If there is product in the path of the blade, it will obstruct the blade or it will be cut. If 2 blades are installed and the system is stopped improperly with the Emergency Stop, the blades will stop immediately where they are. When the system is powered up, there is a 50% chance that the blades will need to move through the product to get home and therefore the product will need to be removed to allow the blade to move to home.

Blade at Cut Position – This sets the position of the blade where it counts the product. It is usually set when it is completely through the product.

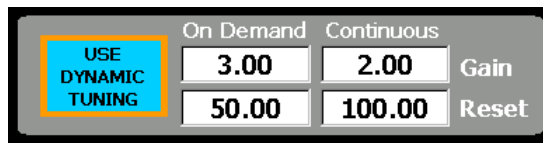

USE DYNAMIC TUNING

Dynamic tuning is used to change tuning parameters when running between on-line and continuous.

On Demand operation requires an extremely fast response with large acceleration torques being used.

Continuous mode prefers a slower response to maintain the set speed in a tighter tolerance.

The values shown in the window can be adjusted to account for changing loads and aging of the equipment. Be very careful changing any of these. Improper settings could cause the servo to become unstable, loose torque or continuously fault. Dynamic tuning can be turned on and off with the button. The servo will use the parameters that were running when it was turned off.

SERVO MOTOR DATA		
GEAR RATIO	0	MOTOR BLADE
RATED MOTOR SPEED	4500	RPM
MAX MOTOR SPEED	4000	RPM
MOTOR TEMP	68.4	°F

SERVO MOTOR DATA– These settings are for reference only. The values are read by the drive and depend on the equipment installed.

Gear Ratio - Shows the gear box attached.

Rated Servo Speed - Rated speed of the motor at rated torque at 400V. It can be affected by the ambient temperature and supply voltage.

Max Servo Speed – This is the maximum possible speed that the motor can obtain though torque will be reduced from the nameplate rating.

Motor Temp – The temperature of the motor. Most motors can handle temperatures up to 140C. Frequent heating and cooling of the motor can cause premature damage.

12.5 Batch Counter Screens

(Accessed through Home Screen)



Counter Screen with Box Count Disabled

Counter Screen with Box Count Enabled

Most of the fields are duplicates of what is on the Quick Ops screen. The following explains the extra buttons.



Count Reset - Press and hold to reset the counters.

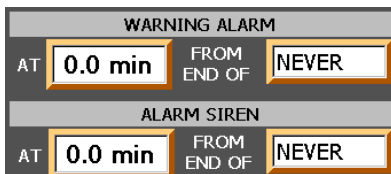

Warnings and Alarms - Signals can be set to activate a warning message or sound a siren when production reaches a certain point. The system calculates the time remaining at the current production rate and determines if the alarm should activate. Set the time in minutes and tenths of minutes and the event to activate the alarm which can be Never, End Of Box, End of

Production, or Both. The Warning Alarm will active a warning message the same way as any other. The Alarm Siren activates the horn only which can be silenced on the Quick Ops Screen. The siren must be configured in the system set up to activate.

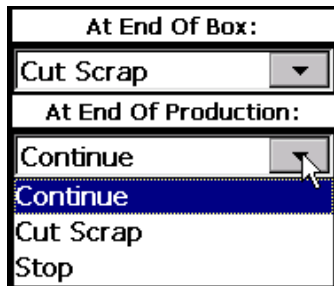

At End of Box: - (Requires box count to be enabled). Used to determine the action of the cutter when the part count has reached the end of box.

At End of Production: – Used to determine the action of cutter when the part count has reached the total pieces setting.

Continue – The cutter keeps cutting the same product and counter keeps incrementing

Cut Scrap – If scrap mode is Enabled, the cutter will execute the scrap recipe and the counter will not increment.

Stop – The cutter will stop.



Enable/Disable Box Count - Press this button to change the counting mode. Box count is enabled if the button is bright.

13.0 SETUP PAGES - NPC-STD -PULLER

Please follow ALL installation and safety procedures described in the instruction manual.

After Cutter Safety procedures and Cutter setup completed:

Press  to access HOME screen. Then press to access PULLER Quick ops.

Setting Up A Production Run

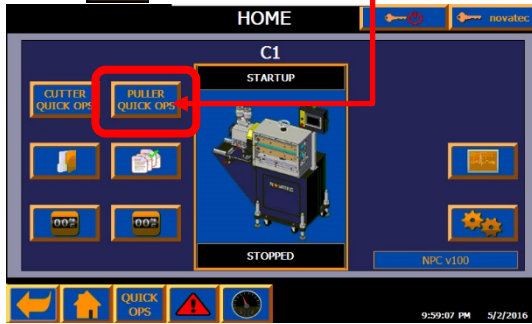

Set belt tension with set screws.



Set compression force with

Speed can be increased or decreased in small increments of 0.1 fpm by pressing the UP or DOWN arrows.

Speed is increased or decreased in 10% increments by pressing +10% or -10%.

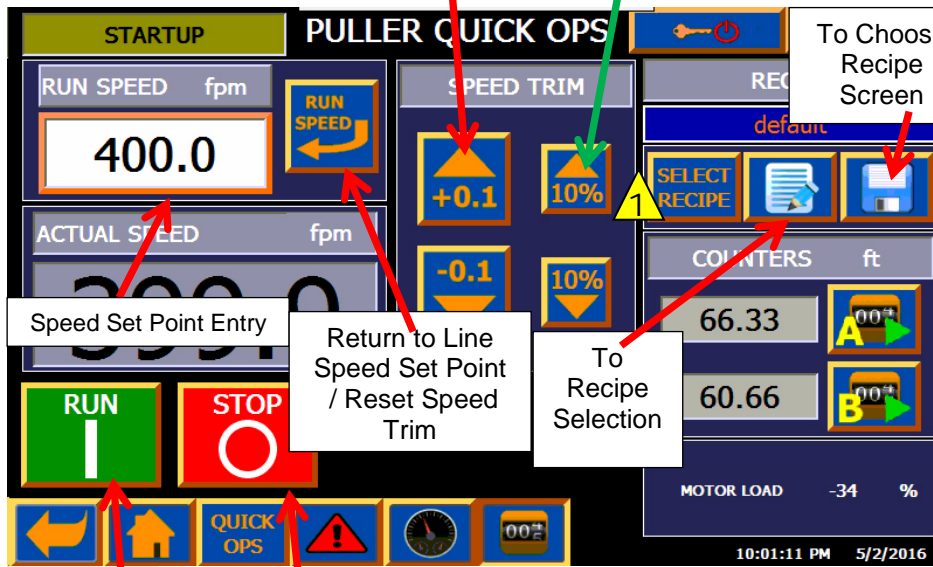

Speed Set Point Entry

Return to Line Speed Set Point / Reset Speed Trim

To Recipe Selection

To Choose Recipe Screen

RUN Machine

STOP Machine

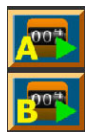

START/PAUSE footage counter for this run

START/PAUSE footage counter for combined runs

13.1 Saving, Selecting and Editing Recipes

- 1 Saving, Selecting and Editing recipes is same for NCP Cutter as for NCP Puller.
 Tapping SELECT RECIPE adds an overlay to the Quick Ops screen.

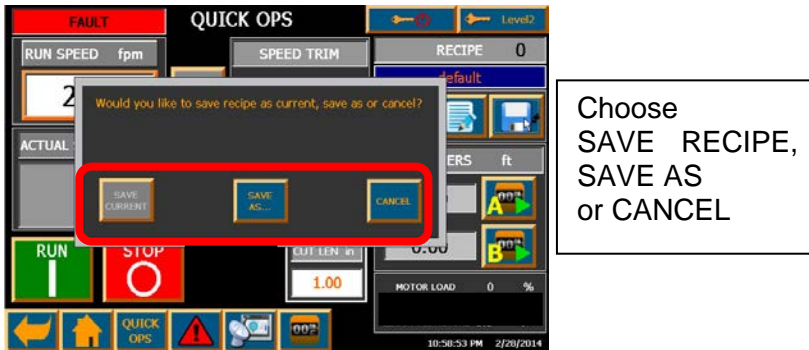

Click a recipe number and add ID and/or Name using alpha/numeric keyboard. Navigate through recipes with UP and DOWN arrows. Click to save.

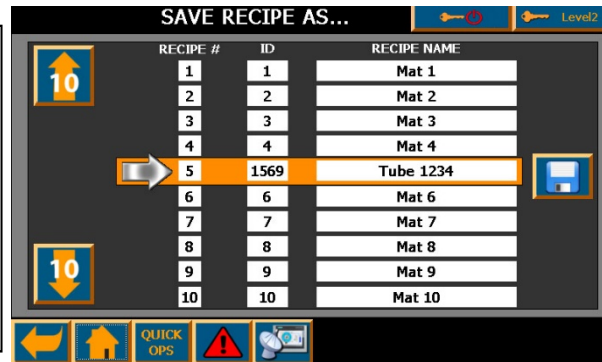

Pressing SELECT RECIPE 1 accesses this screen where up to 30 recipes can be stored and recalled.

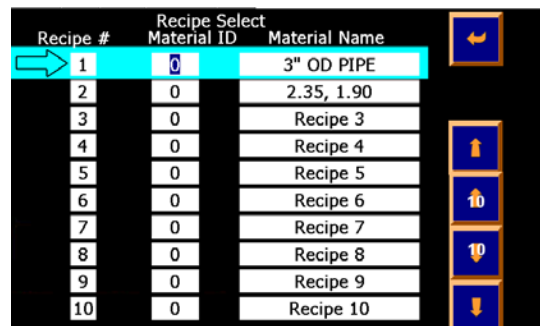

13.2 -Puller Setup Page 1

Level 3 or Setup user login is required to make changes to this page.

SETUP PAGE 1

Belt Thickness Factor (3+) Pre-set at factory.

PULLER BELT PARAMETERS

BELT PITCH DIST. **+0.0250 in**

10.1
62.2

Recipes Can Be Saved To/From SD

5/2/2016 9:57:13 PM

USERS MANAGEMENT

User	Password	Group	Logoff time
Level1	*****	Users	0
Level2	*****	Production	5
Level3	*****	Maintenance	5
PLC User	*****	Unauthoriz...	5
Setup	*****	Setup group	5

12/19/2013 4:26:26 PM

To Previous Page

To USERS MANAGEMENT screen (3+)

5 Press [left arrow] to return to SETUP PAGE 1 and then [QUICK OPS] button.

To replace Level 1, 2, or 3 with an individual's name, press that button and enter the name on the alpha/numeric screen that will appear. A maximum of 4 and a maximum of 9 letters can be used. Touch the [down arrow] arrow after your entry to return to the User Management screen.

To set User Passwords, double tap in the password block and you will be prompted to enter the new password twice.

NOTE: whenever user name is changed, logoff and logon with the new user name is required for the system to backup a new user name.

13.3 -Puller Setup Page 2

MACHINE CONFIGURATION		OUTPUT REFERENCE		EXTERNAL REFERENCE	
MACHINE TYPE	COMBO	CUTTER COMM.	DISABLED	REF. SOURCE	INTERNAL
PULLER VERSION	STD	OUT REF. TYPE	DISABLED	EXT. REF. TYPE	SPEED
GEAR RATIO	20 :1 MID	OUT. REF. SCALING	0.00 fpm	EXT. REF. SCALING	10.00 fpm
DIRECTION OF ROTATION	STANDARD	OUT REF. TYPE	DISABLED	EXT. REF. FILTER DELAY	0.000
INTERLOCK INSTALLED	NO	OUT. REF. FILTER DELAY	0.000	REMOTE REF SWITCH	DISABLED
UNITS	US	OUT. REF. SCALING	0.00 fpm	2ND REF. SOURCE	INTERNAL
USER LINE SPEED LIMITS MIN. LINE SPEED: 2.00 fpm MAX. LINE SPEED: 165.00 fpm				STANDARD SPD. RAMP: 8.0 sec. RET. TO RUN SPD. RAMP: 8.0 sec.	

MACHINE CONFIGURATION PARAMETERS:

MACHINE TYPE – Pre-set at factory

PULLER VERSION – Pre-set at factory

GEAR RATIO – Pertains to installed gearboxes.

DIRECTION OF ROTATION –

STANDARD = RIGHT HAND = (Material Flow from Right to Left

LEFT HAND = Material Flow from Left to Right)

UNITS – US or METRIC

AUTOMATIC LOGON – When enabled, basic machine operation is allowed without a LOGON. (Level 1 User always logged in.)

USER LINE SPEED LIMITS

MIN. LINE SPEED – min Line Speed

MAX. LINE SPEED – Maximum Line Speed

NOTE: User defined speed limits can't be lesser or greater than system speed limits (those depend on the gear reducer size – refer to page 6).

OUTPUT REFERENCE:

CUTTER COM. – Enable/Disable Ethernet communication with NOVATEC cutter.

When enabled, actual line speed will be transmitted to the cutter via network.

OUT REF. TYPE –

Selection of speed or torque for optional analog output signal.

OUT REF. SCALING – Filter for optional analog out signal

EXTERNAL REFERENCE

This parameter set is used whenever there's a requirement to control Puller speed from an external source (e.g. from extruder). Usually, these parameters may require adjustment at the plant.

EXTERNAL REFERENCE	
REF. SOURCE	INTERNAL ▾
EXT. REF. TYPE	SPEED ▾
EXT. REF. SCALING	10.00 fpm
EXT. REF. FILTER DELAY	0.000
REMOTE REF SWITCH	DISABLED ▾
2ND REF. SOURCE	INTERNAL ▾
STANDARD SPD. RAMP	15.0 sec.
RET. TO RUN SPD. RAMP	15.0 sec.

REF. SOURCE – Possible choices are:

INTERNAL - reference is controlled from Puller's HMI)

ANALOG IN - 0-10 VDC analog signal from external device is Used to provide reference

COMMS - reference is received through Ethernet.

(Option currently available for Novatec equipment only).

EXT.REF.TYPE – External reference type with possible SPEED or TORQUE selections (TORQUE reference currently possible with NOVATEC equipment only).

EXT.REF.MAX LINE SPD. – Scaling factor for speed reference. Number entered corresponds to maximum requested line speed at 10 VDC analog signal value.

EXT.REF.FILTER DELAY – time value in seconds for analog signal smoothing. When set to 0, analog signal smoothing is disabled.

REMOTE REF. SWITCH – optional setting. When ENABLED, second reference source can be used. An selector switch or external discrete signal has to be wired to the Puller. With this discrete signal reference sources can be switched (e.g. between internal and external speed reference).

REMOTE REF. SOURCE – second external reference source. Like in the case of REF.SOURCE it can be selected between INTERNAL, ANALOG IN or COMMS (Novatec equipment only). This is valid only when REM. REF. SWITCH is enabled.

SPEED RAMP RATE – Puller's acceleration/deceleration rate (in seconds). Specifies time required to achieve maximum line speed (maximum machine speed depending on the gear ratio, not user limited speed).

13.4 NPC-STD -Puller Setup

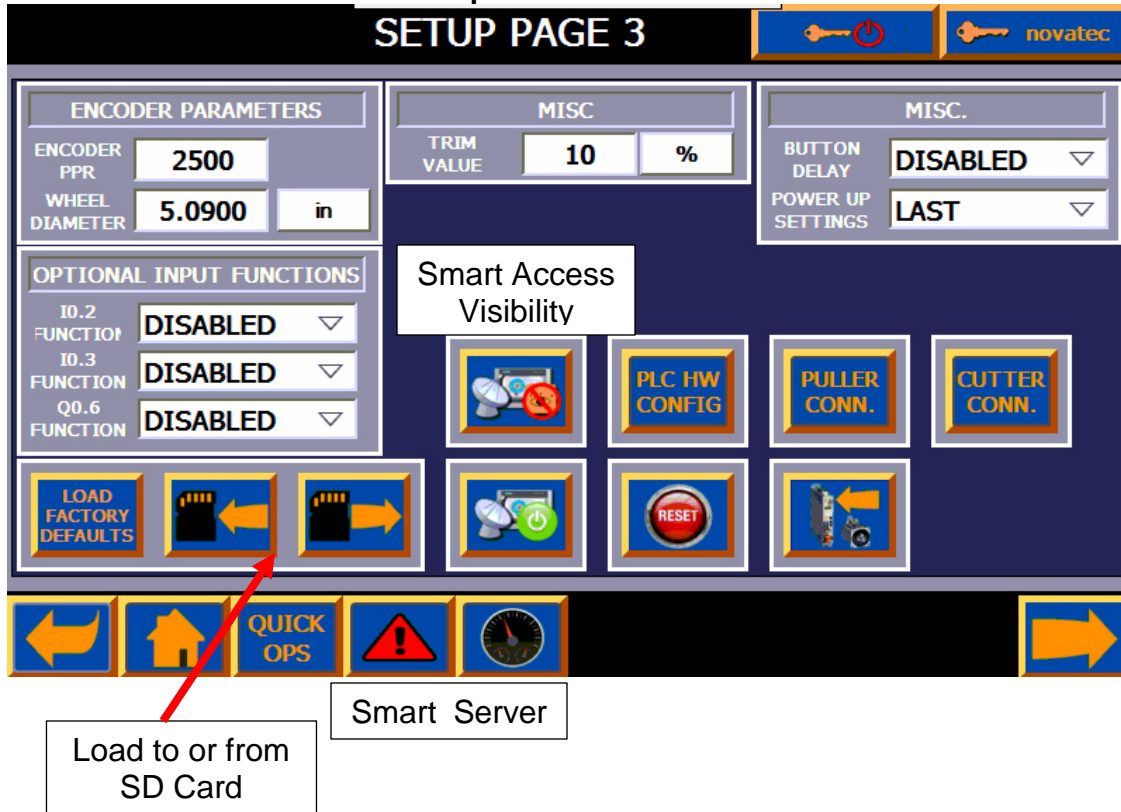

ENCODER PARAMETERS - ENCODER PPR (encoder pulse/rev.) WHEEL DIAMETER (encoder wheel diameter [in])

OPTIONAL INPUT FUNCTIONS - For commands & status bits to external system (i.e. extruder). Where I0.2 FUNCTION can be set to DISABLED/REMOTE START, I0.3 FUNCTION can be set as DISABLED/REMOTE STOP, Q0.6 FUNCTION can be set as DISABLED/STATUS RUN;

14.0 PULLER RECIPE MANAGEMENT

NOVATEC NPS Pullers can be programmed with up to 30 recipes. After recipes are entered, the Level 1 operator can select and load a recipe and the startup speed, run speed as well as the clamp set point will be entered automatically so production startup time will be greatly reduced. Level 2 personnel can save new recipes or modify existing recipes.

14.1 Saving Recipe From Production Run (Quick Ops)

Once your production parameters for a job are finalized, LOGON as Level 2.

Click the SAVE  icon and a pop-up will appear. You can choose

SAVE CURRENT, SAVE AS... or CANCEL.



NOTE:

SAVE CURRENT button is unavailable when default recipe is loaded (RECIPE 0).

If you are saving a new recipe... click SAVE AS and the SELECT RECIPE MENU will appear.

 Click on a Recipe ID (up to 4 characters) and or RECIPE NAME (up to 10 characters) to select location where recipe will be saved then click and the recipe is saved. Edit Recipe screen will be open and recipe can be re-named.

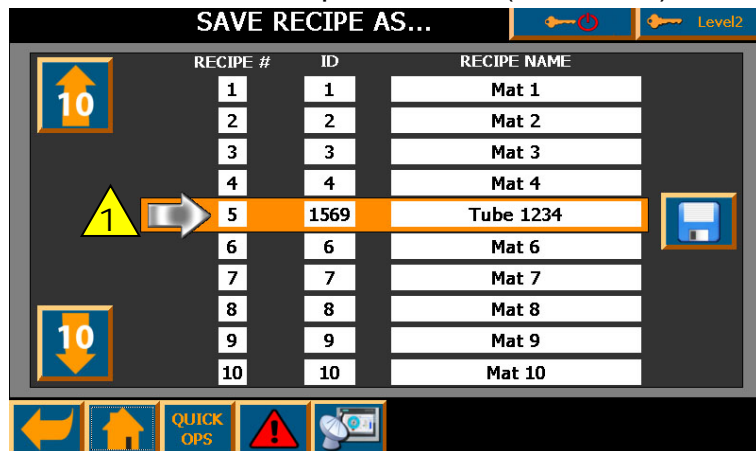

14.2 Editing An Existing Recipe

To edit an existing recipe, select the recipe by pressing the recipe #. note that you can scroll through the recipes, 10 at a time, by pressing the or buttons.

Then press the EDIT icon and the EDIT RECIPE screen (below) will appear. Simply enter the new material ID and/or recipe NAME along with the new parameters. If you press the icon, the recipe will be simply saved for future use. If you press the icon, the recipe will be saved and start to RUN immediately.



NOTE: A Default recipe is installed in each NOVATEC NPC-STD -Puller. It is intended as a default startup recipe for any production run. It can be changed.

14.3 Editing A Current Recipe

You can make changes to the recipe of a product during the RUN mode by pressing The EDIT WORKING RECIPE icon on the Quick Ops screen and modifying parameters in the usual manner. You can then save the changes as a DEFAULT Recipe or press and SAVE AS or CANCEL on the pop-up screen that will appear.

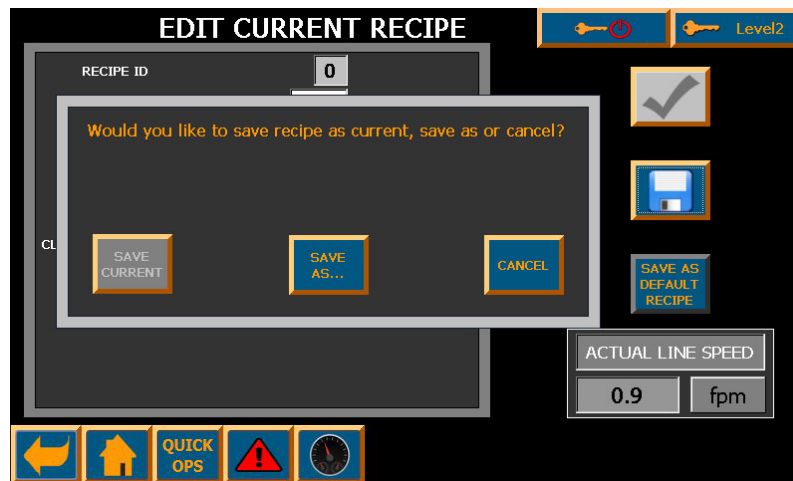

NOTE: Pressing SAVE also automatically activates changes made on the screen.
NOTE: SAVE CURRENT button is unavailable when default recipe is loaded.

When saving as a default recipe a pop-up will appear prompting user to activate recipe as well.

Check mark symbol can be used to activate modified recipe.

15.0 FOOTAGE COUNTER PAGE

Press Footage Counter  button at bottom of HOME page.

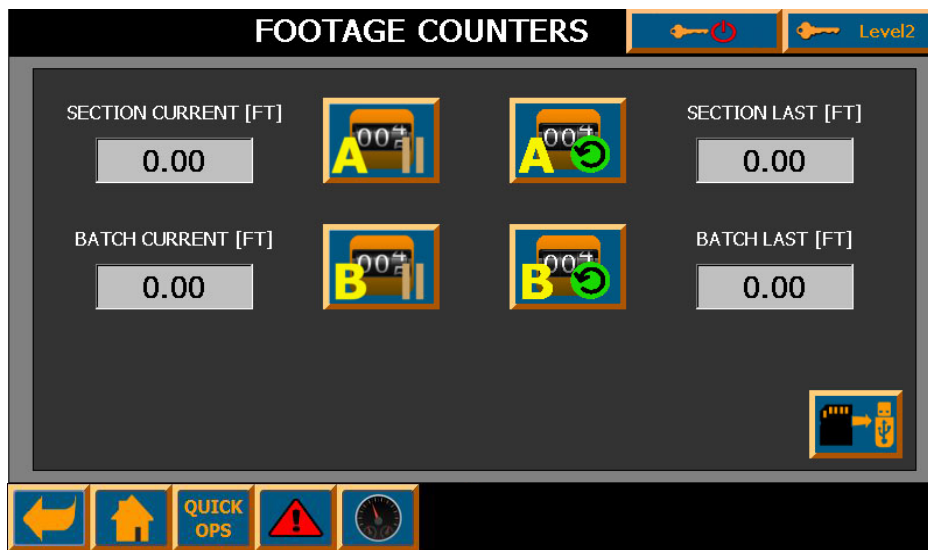

The footage counters start automatically when the NPC-STD -Puller is in the RUN mode.

The footage counter readings from the Quick Ops page also appear on the main Footage Counters page (above).

SECTION CURRENT records the footage run during the current shift (or until the counter is re-set).

BATCH CURRENT records the combined totals from the SECTION CURRENT readings.

Either of the above can be paused and resumed or re-set to ZERO by pressing respective A or B counter PLAY/PAUSE or reset buttons.

Any time the SECTION CURRENT or the BATCH CURRENT is re-set, those values are transferred as the SECTION LAST and the BATCH LAST readings. These can also be re-set to ZERO by pressing and holding the respective buttons.

This information can be helpful in deterng the total footage being produced by each shift and from one day to another. These footages can also be compared to the useable product produced to calculate the amount of scrap being produced at any given time.

16.0 SYSTEM DIAGNOSTICS SCREENS

Press System Diagnostics icon  on HOME page to access this page.

This screen has three different views that can be changed by pressing tabs in the upper part of the screen (System Info, I/O Status and Actual Values).

The screenshot displays the 'SYSTEM DIAGNOSTIC' interface. At the top, there are three tabs: 'SYSTEM INFO' (selected), 'I/O STATUS', and 'ACTUAL VALUES'. The 'SYSTEM INFO' view is divided into three main sections: 'MACHINE CONFIGURATION', 'OUTPUT REFERENCE', and 'EXTERNAL REFERENCE'. Below these are 'USER LINE SPEED LIMITS' and 'MISC' settings. A navigation bar at the bottom includes icons for back, home, quick ops, warning, and a gauge.

SYSTEM DIAGNOSTIC		
SYSTEM INFO	I/O STATUS	ACTUAL VALUES
MACHINE CONFIGURATION		
GEAR RATIO	58.33 : 1	
DIRECTION OF ROTATION	STANDARD	
MACHINE VERSION	US	
UNITS	US	
AUTOMATIC LOGON	DISABLED	
OUTPUT REFERENCE		
OUT REF. TYPE	DISABLED	
CUTTER COMM.	DISABLED	
CUTTER OUTPUT	DISABLED	
CUTTER PLS. DURATION	80	ms
CUTTER PLS. DELAY	0	ms
CUTTER CPM	100	
EXTERNAL REFERENCE		
REF. SOURCE	INTERNAL	
EXT. REF. TYPE	SPEED	
EXT. REF. MAX LINE SPD.	10.00	fpm
EXT. REF. FILTER DELAY	1.000	
REMOTE REF SWITCH	DISABLED	
REMOTE REF. SOURCE	INTERNAL	
STANDADT SPD. RAMP	15.0	sec.
RET. TO RUN SPD. RAMP	15.0	sec.
USER LINE SPEED LIMITS		
MIN. LINE SPEED	3.75	fpm
MAX. LINE SPEED	50.00	fpm
MISC		
TRIM VALUE	10	%

System Info view shows all machine setup parameters.



I/O Status view shows current LED status of PLC discrete inputs and outputs as well as current voltages read at analog inputs AI0 and AI1.

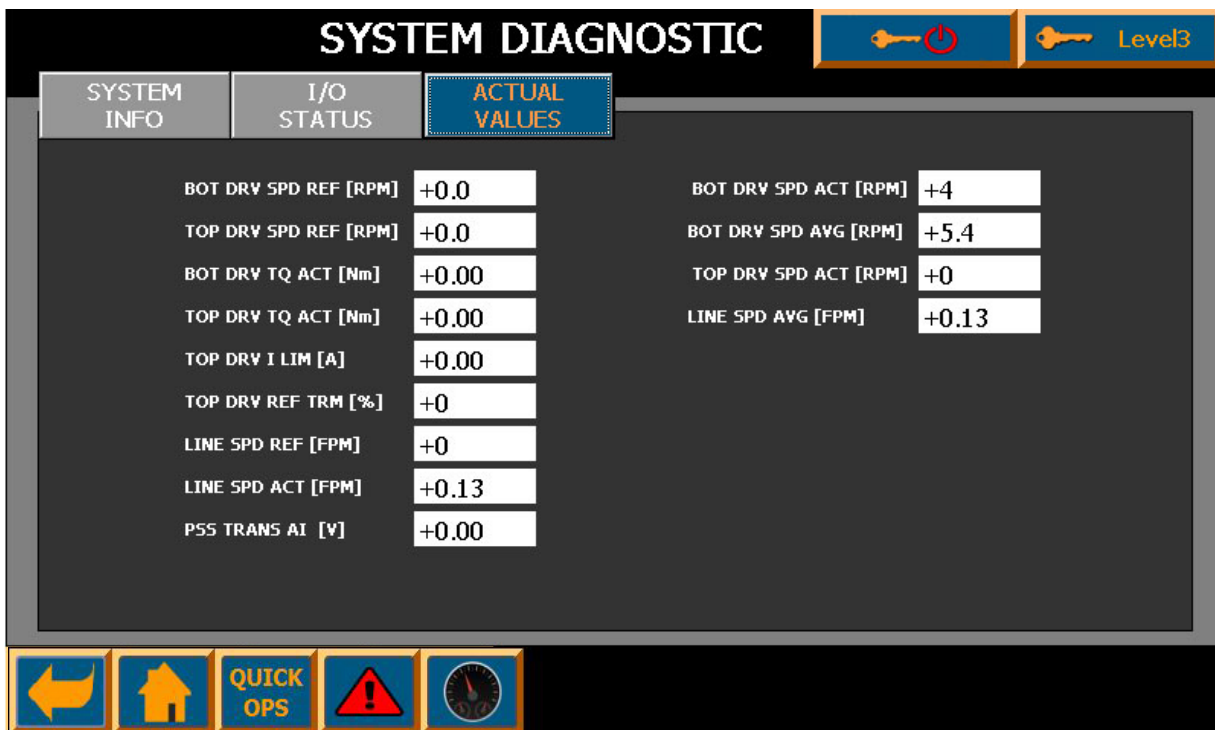

Actual Values view shows most actual machine values (e.g. motor speeds, torques etc.).

A full range of diagnostics can be accessed including:

- BOT DRV SPD REF – is commanded speed of bottom drive
- TOP DRV SPD REF – is commanded speed of top drive
- BOT DRV TQ ACT – actual torque of the bottom belt motor [%]
- TOP DRV TQ ACT – actual torque of the top belt motor [%]
- TOP DRV U TQ LIM – maximum torque limit of upper drive
- TOP DRV REF TRM[%] – additional torque trim applied to factory settings increase to provide additional torque assist, decrease to reduce torque assist from top belt
- LINE SPD REF [ft./min] – set line speed
- LINE SPD ACTUAL [ft./min] – calculated line speed based on the current motor rpm, pulley diameter, belt thickness and gear ratio
- PSS TRANS AI [V] – actual voltage read at analog input AI0 (voltage of the pressure transducer)
- BOT DRV SPD ACT – is instantaneous speed of bottom drive [rpm]
- TOP DRV SPD ACT – is instantaneous speed of top drive [rpm]
- BOT DRV SPD AVG – is moving average speed of bottom drive [rpm]
- TOP DRV SPD AVG DRV – is moving average speed of top drive [rpm]
- LINE SPD AVG – aggregate average of top and bottom drive averages [rpm]

17.0 ALARM SCREENS

If the alarm light flashes, pressing the  button or VIEW ALARM button whenever New Alarm Present pop-up window is present on the Quick Ops screen, displays Current Alarms screen. All current alarms are shown in the table together with short alarm descriptions.



Pressing View Alarm button on the New Alarm Present pop-up window will close pop-up and open Current Alarm screen. Pressing IGNORE will close pop-up only.

3/11/2014
8:17:18 PM

CURRENT ALARM

Level 1

No.	Time	Date	Status	Text	GR
110	8:02:36 PM	3/11/2014	I	Belt tension air pressure too low.	0
107	8:02:36 PM	3/11/2014	I	EStop / Safetys are not OK. Check EStop, safety switch,...	0
104	8:02:36 PM	3/11/2014	I	Top drive Profinet fault. Check connection between the d...	0
101	8:02:36 PM	3/11/2014	I	Bottom drive fault No. 5200 See drive manual.	0

QUICK
OPS

ALARM
HISTORY

Pressing alarm name selects it. To acknowledge and reset selected alarm, press button.

To get more information on the selected alarm, press button. A small pop up window will show up with more detailed alarm description and suggested actions to clear it.

Pressing ALARM HISTORY button located in the right bottom corner of the alarm screen will change view from Current Alarm to the Alarm History.

3/11/2014 8:18:20 PM		ALARM HISTORY				Level3
No.	Time	Date	Status	Text	GR	
\$ 260000	8:12:38 PM	3/11/2014	I	Invalid password or user name. Logon has failed.	0	
\$ 80029	8:02:51 PM	3/11/2014	I	Log initialization ended. 1 logs reported errors.	0	
\$ 80015	8:02:50 PM	3/11/2014	I	Alarm_log_10 - The system cannot find the drive specifie...	0	
I 110	8:02:36 PM	3/11/2014	I	Belt tension air pressure too low.	0	
I 107	8:02:36 PM	3/11/2014	I	EStop / Safetys are not OK. Check EStop, safety switch,...	0	
I 104	8:02:36 PM	3/11/2014	I	Top drive Profinet fault. Check connection between the d...	0	
I 101	8:02:36 PM	3/11/2014	I	Bottom drive fault No. 5200 See drive manual.	0	
\$ 140000	8:02:36 PM	3/11/2014	I	Connection established: HMI_connection_1, Station 192....	0	
\$ 70018	8:02:34 PM	3/11/2014	I	User administration imported successfully.	0	
\$ 110001	8:02:34 PM	3/11/2014	I	Change to operating mode 'online'.	0	
\$ 70022	8:02:34 PM	3/11/2014	I	User administration import started.	0	
\$ 80028	8:02:33 PM	3/11/2014	I	Log initialization started.	0	
\$ 270006	8:02:32 PM	3/11/2014	I	Project modified: Alarms cannot be restored from the pe...	0	

QUICK OPS

CLEAR ALARM HISTORY

CURRENT ALARM

Alarm History view shows more detailed information like time and date when alarm, when alarm was acknowledged, when alarm condition was cleared (alarm is gone) as well as system alarms and events (like when user tried to logon but entered wrong username or password).

Alarm History buffer can be cleared by the user by pressing CLEAR ALARM HISTORY button (this action requires Level3 authorization).

Symbols in column Status represent status of the alarm event:

- I - means alarm occurred
- A – means alarm was acknowledged
- O – means alarm condition was cleared (alarm is no longer present)

18.0 -PULLER OPERATION



DANGER! PINCH POINT
 Never get clothing or any part of your body near pinch points

DANGER: Never remove or disable safety devices to sustain production. Operating without these safety devices could lead to hazardous conditions that can cause severe injury. Take all necessary precautions when working around moving parts to prevent body parts and clothing from being pulled into the machine.

1. Make sure all components properly installed and hardware is tight.
2. Check that puller is firmly anchored with floor locks.
3. Ensure machine is properly wired and all enclosure doors are closed.
4. Push E-Stop pushbutton.
5. Power on the machine.
6. The following **System Overview** screen will appear on the control panel.



19.0 -PULLER MAINTENANCE

It is recommended that maintenance and inspection be performed on a scheduled basis. Maintenance requirements may vary widely for each installation and specific operating conditions. It is suggested that a complete inspection be performed with necessary maintenance at the end of the first month, the first three months, and the first six months. These inspections will indicate how often future maintenance will be necessary.

- ❑ All electrical, mechanical repairs and tests are to be performed by qualified personnel only.
- ❑ Disconnect electric power from control box before opening panel for maintenance.
- ❑ Do not disable or bypass equipment safety features.
- ❑ Refer to system component manuals for additional information.



WARNING: Before beginning repair work, disconnect all power sources and secure against inadvertent reconnection.



WARNING: Auxiliary equipment may contain moving parts that may cut, crush, or otherwise injure personnel when safety/access covers are removed. Do not place hands or limbs in equipment during operation.

At Startup

- ❑ Verify all guards are in place and able to be fully closed.
- ❑ Ensure belt tension is set properly
- ❑ Record equipment Serial Numbers and the NPC-STD Controller program revision level.

Every Belt Change

- ❑ Inspect condition of line pace encoder if used.

Daily

- ❑ Inspect belts for wear and tear
- ❑ Check belt tension
- ❑ Verify puller alignment
- ❑ Verify full travel available in traction assemblies
- ❑ Every 3 Months
 - ❑ Check all electrical connections to make sure that they have not become loose, especially those connections at contactors, like motor starters.
 - ❑ Monitor gear reducer temperature. Gear reducer temperature should not exceed 200°F (93°C) at any time or operating condition. See gear reducer manual for further maintenance instructions.

20.0 -CUTTER MAINTENANCE

It is recommended that maintenance and inspection be performed on a scheduled basis. Maintenance requirements may vary widely for each installation and specific operating conditions. It is suggested that a complete inspection be performed with necessary maintenance at the end of the first month, the first three months, and the first six months. These inspections will indicate how often future maintenance will be necessary.

- ❑ All electrical, mechanical repairs and tests are to be performed by qualified personnel only.
- ❑ Disconnect electric power from control box before opening panel for maintenance.
- ❑ Cutter enclosure may be hot. Components inside the enclosure will be hotter than the air inside, especially the servomotor and resistor.
- ❑ Do not disable or bypass equipment safety features.
- ❑ Refer to system component manuals for additional information.



WARNING: Before beginning repair work, disconnect all power sources and secure against inadvertent reconnection.



WARNING: Auxiliary equipment may contain moving parts that may cut, crush, or otherwise injure personnel when safety/access covers are removed. Do not place hands or limbs in equipment during operation.

At Startup

- ❑ Verify all guards are in place and able to be fully closed.
- ❑ Ensure blades are attached securely.
- ❑ Record equipment Serial Numbers and the NPC-STD Controller program revision level.

Every bushing or blade change

- ❑ Verify free motion of blade(s) past bushings and that bushing gap is properly set

Daily

- ❑ Clean bushings and lubricant tray.

Every 3 Months

- ❑ Check all electrical connections to make sure that they have not become loose, especially those connections at contactors, like motor starters.

21.0 WARRANTY – NOVATEC, INC. - Effective Date 21 Jan 2016

NOVATEC, INC. offers comprehensive product warranties on all of our plastics auxiliary equipment. We warrant each NOVATEC manufactured product to be free from defects in materials and workmanship, under normal use and service for the periods listed under “warranty periods”. The obligation of NOVATEC, under this warranty, is limited to repairing or furnishing, without charge, a similar part to replace any part which fails under normal use due to a material or workmanship defect, within its respective warranty period. It is the purchaser’s responsibility to provide NOVATEC with immediate written notice of any such suspected defect. Warranted replacement parts are billed and shipped freight pre-paid. The purchaser must return the suspect defective part, freight prepaid and with identifying documentation to receive full credit for the part returned. NOVATEC shall not be held liable for damages or delay caused by defects. No allowance will be made for repairs or alterations without the written consent or approval of NOVATEC.

The provisions in equipment specifications are descriptive, unless expressly stated as warranties. The liability of NOVATEC to the purchaser, except as to title, arising out of the supplying of the said equipment, or its use, whether based upon warranty, contract or negligence, shall not in any case exceed the cost of correcting defects in the equipment as herein provided. All such liability shall terminate upon the expiration of said warranty periods. NOVATEC shall not in any event be held liable for any special, indirect or consequential damages. Commodities not manufactured by NOVATEC are warranted and guaranteed to NOVATEC by the original manufacturer and then only to the extent that NOVATEC is able to enforce such warranty or guaranty. NOVATEC, Inc. has not authorized anyone to make any warranty or representation other than the warranty contained here. Non-payment of invoice beyond 90 days will invalidate the warranty. A renewed warranty can be purchased directly from NOVATEC.

Please note that we always strive to satisfy our customers in whatever manner is deemed most expedient to overcome any issues in connection with our equipment.

Warranty Period:

Note: All warranty periods commence with the shipment of the equipment to the customer.

5 YEARS

NPS Bessemer Series Pullers	NVT Vacuum Tanks	C Bessemer Series Cutters
NCT Cooling Tanks	NC Bessemer Series Cutters	NS Series Upcut Saws
NPC-STD Puller Cutters		

1 YEAR**Custom Equipment****Exclusions:**

Routine maintenance/replacement parts are excluded from the warranty. These include, but are not limited to: belts, rollers, bushings, knives, hoses, gaskets, seals, motors, internal solenoids, fuses and motor brushes. Use with abrasive materials will void the warranty of any standard product. NOVATEC reserves the right to limit the warranty if the customer installs replacement parts that do not meet the specifications of the original parts supplied by NOVATEC.

This warranty shall not apply to equipment:

1. Repaired or altered without written approval of NOVATEC unless such repair or alteration was, in our judgment, not responsible for the failure
2. Which has been subject to misuse, negligence, accident or incorrect wiring by others
3. Warranty is void if processing rates exceed manufacturer-recommended levels or if damage is caused by ineffective power isolation and/or power spikes/sags or incorrect installation.

NOTE: All conditions and content of this warranty are subject to changes without notice.

NOVATEC, Inc.
222 E. Thomas Ave.
Baltimore, MD 21225 www.novatec.com