

VPDB Vacuum Pumps

MODELS:

- >VPDB-3
- >VPDB-5
- >VPDB-7.5
- >VPDB-10
- >VPDB-10/3
- >VPDB-15
- >VPDB-20



In the space provided below you should record the model and serial number(s) of your equipment and the date the equipment was received.

In the event you would need aftermarket assistance our parts and service department uses this information, along with the manual number, to provide help for the specific equipment installed.

Please keep this instruction manual, any relevant addendums, engineering prints and parts lists together for accurate documentation of your equipment.

User Manual: VPDB-UG 19 FEBRUARY 2020
Serial Number(s):
Model Numbers:

NOTES

DISCLAIMER: NOVATEC, Inc., shall not be liable for errors in this instruction manual. Information can change without notice. Novatec makes no warranty of any kind concerning the information contained herein, including, but not limited to the implied warranties of merchantability and fitness for a particular purpose.

Table of Contents

1.0 INTRODUCTION	4
2.0 WARNING	4
3.0 OPERATING LIMITATIONS	4
3.1 Operating at Higher Altitudes	4
3.2 Seek Time	4
4.0 UNPACKING	4
5.0 GENERAL INSPECTION	4
6.0 MECHANICAL INSTALLATION	5
6.1 Compressed Air Supply:	5
6.2 Regulator Warning	5
6.3 Combination Vacuum Breaker and Vacuum Relief Valve	5
6.4 Discharge Selection Valve (DSV)	5
6.5 Closed Loop Vacuum System	5
6.6 Closed Loop Dry Air Vacuum System	6
6.7 Ambient Air Vacuum Conveying System	6
7.0 ELECTRICAL INSTALLATION	7
8.0 STANDARD SPECIFICATIONS	8
9.0 OPERATING AT HIGH ELEVATIONS	8
10.0 PARTS LIST	8
11.0 MAINTENANCE AND INSPECTION SCHEDULE	9
11.1 Belt Adjustment and Replacement	9
11.1.1 Inspecting V-Belts	9
11.1.2 Replacing V-Belts	10
11.2 Special Note: Sheave Re-installation	10
11.3 Cleaning Air Filter	10
11.4 Removing Sound Curtains	10
11.5 Blower Lubrication	11
12.0 WIRING DIAGRAM	12
13.0 WARRANTY	15

1.0 INTRODUCTION

NOVATEC VPDB Series Vacuum Pumps are designed to pneumatically convey plastic pellets or powders in a vacuum conveying system. It does this by creating a vacuum to “pull” air through the piping system. Plastic pellets or powders are introduced into the moving air stream in various ways, including through the use of probes, pick-up tubes, and rotary air locks. The VPDB is used in conjunction with vacuum chamber station valves, etc. to form the conveying system, which is controlled with either Master Control or Distributed Control Panels. Several vacuum power units may be designed into the system as required. Vacuum conveying systems typically distribute material from silos, surge bins, blenders, or drying hoppers to processing machinery.

2.0 WARNING

Always disconnect power before servicing. Only qualified technicians should service, maintain, or repair the VPDB. Before using this equipment, read in detail the product bulletins and other information found in this manual. A safe installation is necessary before operating the equipment. The instructions should be understood and followed before installing or operating the equipment.

3.0 OPERATING LIMITATIONS

3.1 Operating at higher altitudes— 3000 ft above sea level or more.

Atmospheric pressure is lower at higher elevations and as a result, the compression of air by the pump requires more work for vacuum conveying. In these higher altitude applications the pressure relief valve of VPDB pumps must be adjusted on site to prevent the pump from damaging itself or the motor by attempting to compress air of reduced density to an unsafe level. Contact Novatec Engineering or Service at the number on the front cover of this manual when operating the pump at 3000 ft or higher elevation.

Blower exhaust temperature and motor cooling are a function of both vacuum level and elevation. Blower exhaust temperature must not exceed 300°F to avoid premature blower failure.

Decreased motor FLA limits may require alternate overload protection or increased frame size/Hp.

3.2 Seek Time

Excessive starting and stopping of the pump will reduce blower and motor life and void the warranty. Seek Time is a control parameter that allows your pump to operate for short periods in vacuum break mode (no vacuum loading) while the system control searches for new demands.

Using the Seek Time feature, pump starts must be limited to 12 per hour to prevent premature failure. The minimum Seek Time for a pump is 180 seconds to prevent exceeding 12 starts per hour. Optimum Seek Time may be set dependent upon pump capacity, utilization, number of stations, capacity of each vacuum chamber, and individual station throughputs. (See your control panel instruction manual for information on Seek Time)

4.0 UNPACKING

Caution should be exercised to see that the equipment is not handled roughly. The crate must be removed carefully. The machine must not be used to pry against. Do not pry against the machine when removing the crate. The vacuum power unit is usually shipped completely assembled and requires no further attention prior to installation. Note any shipping damage on delivery receipt and report immediately to trucking company.

5.0 GENERAL INSPECTION

When the unit is unpacked, make a visual inspection looking for missing parts or damage that may have occurred during shipment. Report any missing parts to Novatec immediately. All electrical and mechanical connections should be checked for tightness, as vibration during transit may cause them to loosen.

IMPORTANT: Before placing the vacuum pump into service, be sure oil has been put in the pump, as oil may have been drained following factory quality control testing. See page 11 for lubrication guidelines.

Note that replacement blowers are shipped without oil.

6.0 MECHANICAL INSTALLATION

Only qualified technicians familiar with local and national codes should install this equipment. Connect the vacuum lines as shown on the installation drawings. Connect the compressed air (80 - 120 psig) to air actuated valves as required.

Locate the pump where it can be interconnected with the vacuum system piping easily.

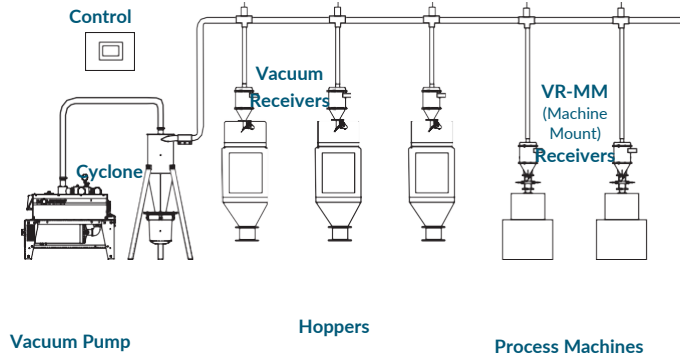

Accommodations should be made to allow full access of the pump for service, especially the belt guard, starter, filter, vacuum breaker valve, vacuum blower and vacuum relief valve. The vacuum gauge should be visible but can be carefully rotated in its fitting as required. The pump

should be secured to the floor to prevent movement from vibration and isolating pads (not supplied) may be installed to minimize noise transfer to the floor, if desired.

The pump is commonly located near the vacuum conveying system's cyclone dust collector and is commonly connected directly to the cyclone lid with rigid tubing or flex hose.

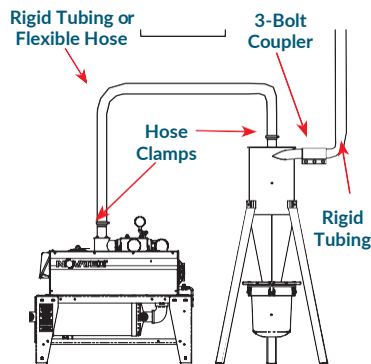

It is convenient to service the dust collector and the pump filter at the same time.

6.1 Compressed Air Supply:

Clean compressed air should be supplied to the VPDB pump's vacuum breaker valve regulator, providing 80 to 120 psig. A filter (not supplied) should be provided if the cleanliness of the air is questionable.

6.2 Regulator Warning



The compressed air regulator has been set at the factory to allow the vacuum breaker to relieve at the specified vacuum. **Tampering with the regulator will void the warranty.** Only qualified Novatec service personnel may adjust the relief point via regulator pressure.

Pump Model	Relief Point for 60hz Operation	Regulator Setting
VPDB-3	12.0" Hg	29 psig
VPDB-5	12.5" Hg	30 psig
VPDB-7.5	12.5" Hg	30 psig
VPDB-10	12.5" Hg	30 psig
VPDB-10/3	12.5" Hg	30 psig
VPDB-15	12.5" Hg	30 psig
VPDB-20	12.5" Hg	30 psig

6.3 Combination Vacuum Breaker and Vacuum Relief Valve

The Novatec vacuum breaker valve for system seek operation also serves as the vacuum relief valve to regulate the pump's workload. The dual functionality is accomplished by utilizing an equilibrium of compressed air pressure and vacuum level in conjunction with the vacuum breaker action, governed by the system's conveying control panel.

NOTE: Specifications will be reduced for standard pump assemblies running on 50Hz. Information shown is for standard VPDB vacuum pumps. Refer to special job draw-

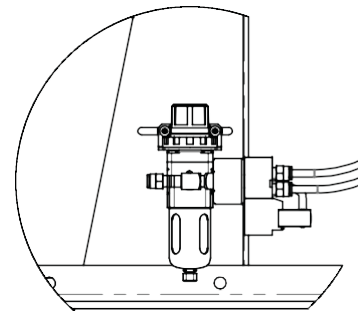

Located behind electrical control box

ings for custom unit information if applicable.

6.4 Discharge Selection Valve (DSV)

Pump exhausts to atmosphere or can be pipe outside of pump room.

- Requires a separate Relief Vent in a closed system.
- Includes 3-Bolt Coupler and pump adapter fitting.
- For use with either VRB or VPDB pumps

6.5 Closed Loop Relief Vent (CLR)

Provides Pressure Relief in a Closed Loop Conveying System.

- Install near take-off devices in a closed loop system.
- Install one per row of take-offs that share a common closed loop manifold.

6.6 Closed Loop Dry Air Vacuum System

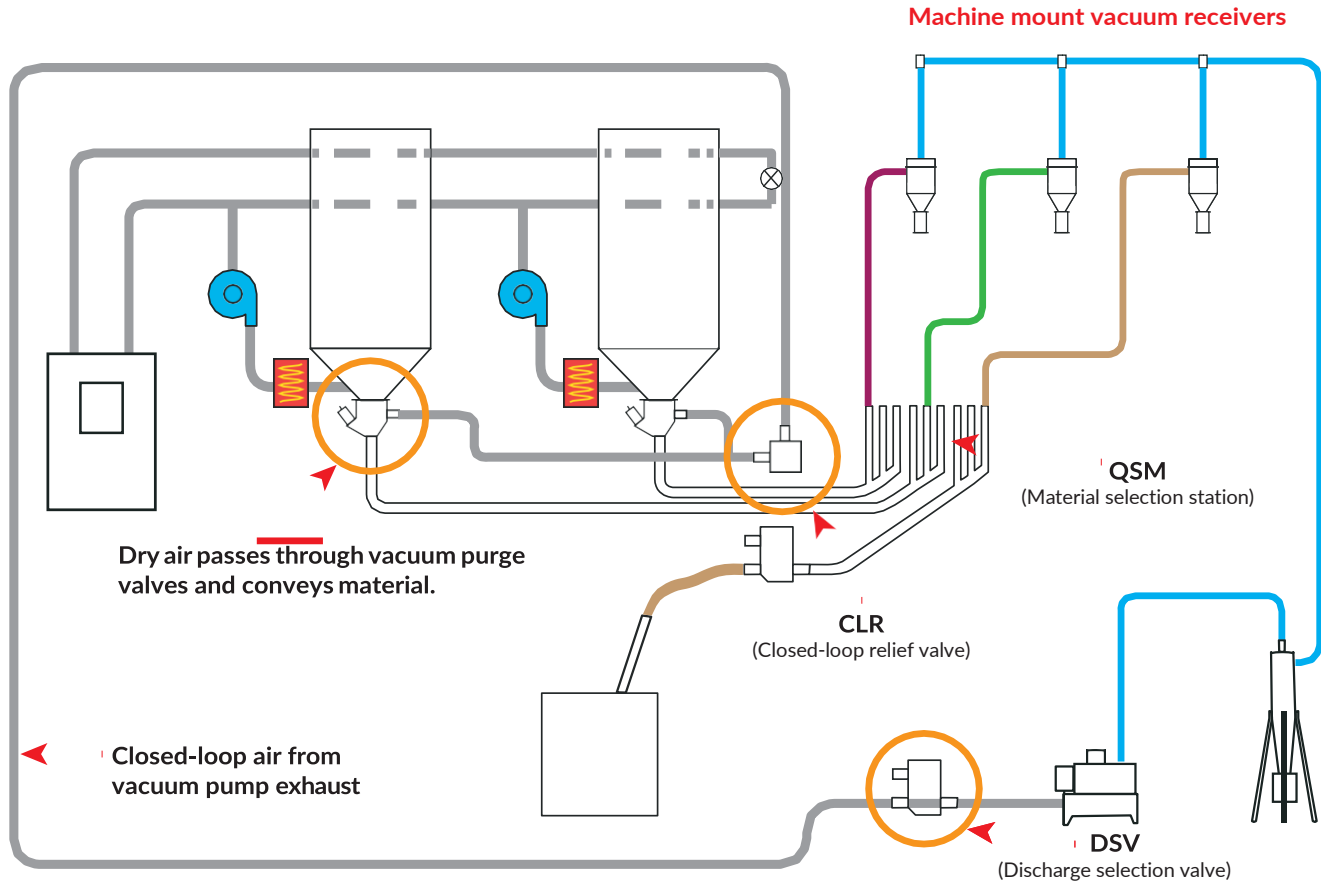

6.7 Ambient Air Vacuum Conveying System

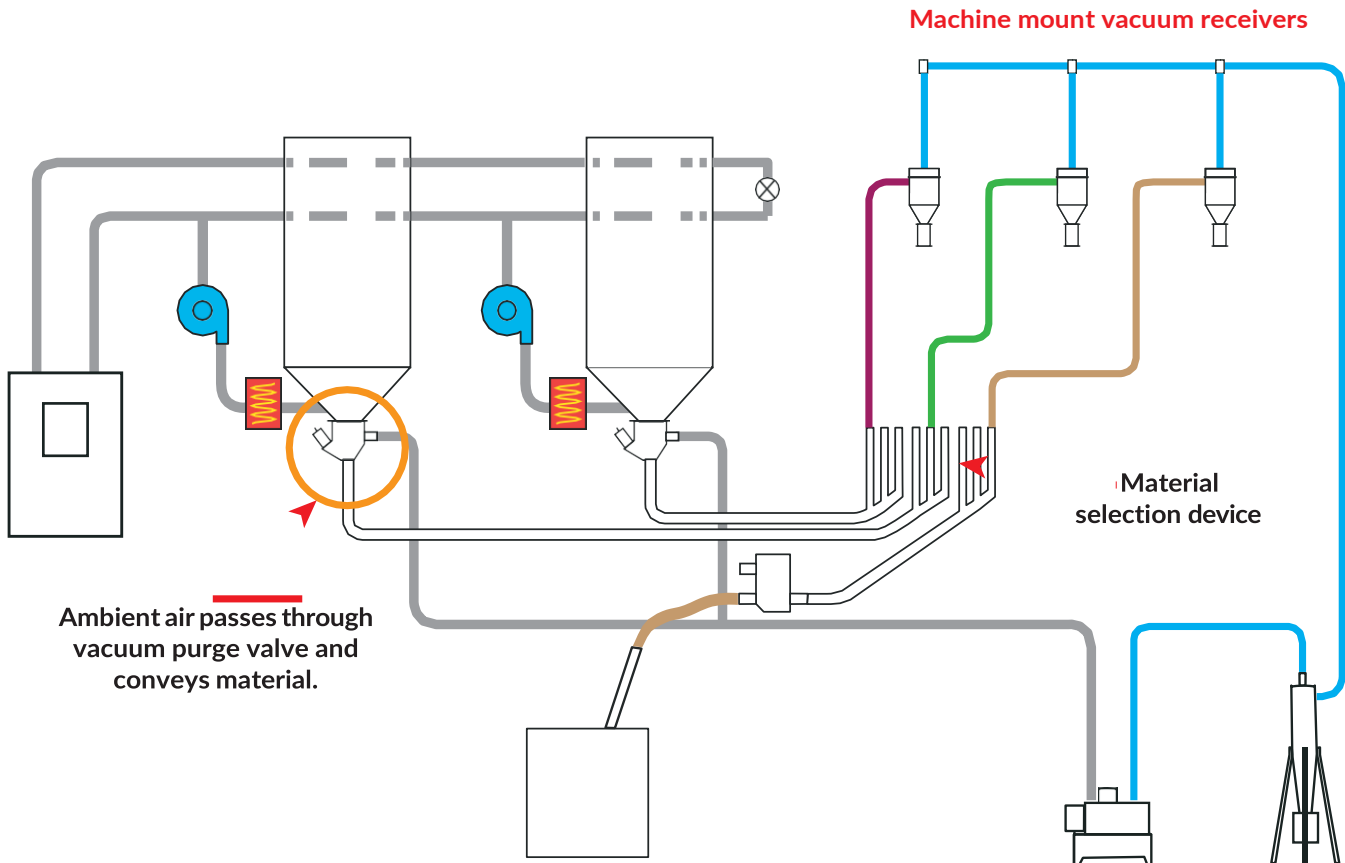

7.0 ELECTRICAL INSTALLATION

Connect the proper power supply (check nameplate) through a main line disconnect switch (not supplied) to terminal connections L1, L2, L3 and ground into the VPDB control cabinet that contains the motor starter. This is the only power connection required since the motor is pre-wired at the factory. See schematics with this package. See FLA specification table below.

Connect control wiring from the conveying system control panel to the same electrical enclosure as shown on the wiring schematic for the conveying system control panel. Verify the correct rotation of the motor with the directional labels on the pump assembly.

7.1 3-Phase Electrical Power

1. Verify nameplate information on the pump frame assembly.
2. Use the FLA/KVA chart below as a guide
3. A nominally rated 3-phase disconnect switch must be provided.
4. All connections must be provided in strict adherence to local and national codes by a qualified electrician.

7.2 FLA / KVA Listings

Full Load Amperage and KVA ratings for VPDB vacuum pumps by model and voltage:

Horsepower	Voltage	FLA	KVA
VPDB-3 3HP	208/3/60	9.4	3.5
	230/3/60	8.5	3.5
	400/3/50	5.2	3.5
	460/3/60	4.3	3.5
	575/3/60	3.5	3.5
VPDB-5 5HP	208/3/60	14.3	5.0
	230/3/60	13.0	5.0
	400/3/50	7.3	5.0
	460/3/60	6.5	5.0
	575/3/60	5.0	5.0
VPDB-7.5 7.5HP	208/3/60	21.3	7.8
	230/3/60	19.4	7.8
	400/3/50	11.4	7.8
	460/3/30	9.7	7.8
	575/3/60	7.8	7.8
VPDB-10 10HP (2.5" OD Vacuum Tubing)	208/3/60	29.5	10.7
	230/3/60	26.8	10.7
	400/3/50	15.6	10.7
	460/3/60	13.4	10.7
	575/3/60	10.7	10.7
VPDB-10/3 10HP (3.0" OD Vacuum Tubing)	208/3/60	29.5	10.7
	230/3/60	26.8	10.7
	400/3/50	15.6	10.7
	460/3/60	13.4	10.7
	575/3/60	10.7	10.7
VPDB-15 15HP	208/3/60	43.3	15.7
	230/3/60	39.4	15.7
	400/3/50	22.8	15.7
	460/3/60	19.7	15.7
	575/3/60	15.8	15.7
VPDB-20 20 HP	208/3/60	56.4	20.3
	230/3/60	51	20.3
	400/3/50	29.3	20.3
	460/3/60	25.5	20.3
	575/3/60	20.4	20.3

8.0 STANDARD SPECIFICATIONS

(3000 ft. elevation and below)

Model	Hp	CFM	Max Recommended Operation Vacuum	Line Size (OD)
VPDB-3	3	55	11" Hg	1½"
VPDB-5	5	100	11.5" Hg	2"
VPDB-7.5	7.5	155	11.5" Hg	2½"
VPDB-10	10	170	11.5" Hg	2½"
VPDB-10/3	10	235	11.5" Hg	3"
VPDB-15	15	250	11.5" Hg	3"
VPDB-20	20	470	11.5" Hg	4"

Information shown is for standard VPDB series Positive Displacement vacuum pumps. Specifications will be reduced for 50Hz. Specifications will change when the pump is operated at elevations 2000 ft. or more above sea level (see section below).

NOTE: Refer to special job drawings for custom unit information if applicable. Verify nameplate information on motor before installing and operating. All information is subject to change without notice.

10.0 PARTS LIST

QTY	DESCRIPTION	MODEL						
		VPDB-3	VPDB-5	VPDB-7.5	VPDB-10	VPDB-10/3	VPDB-15	VPDB-20
1	Blower	PD-3M-HORZ	PD-3M-HORZ	PD-4M-HORZ	PD-4M-HORZ	PD-4M-HORZ	PD-5M-HORZ	MVP-P408-HORIZ
1	Motor 230/460/3/60	01913	01914	01915	01916	01916	01917	98-0868
1	Motor 575/3/60	04202	04199	04823	03596	03596	04200	14294
1	Vacuum Gauge	50011						
1	V-Belt	BX55	BX57					
2	V-Belt			BX57	BX57	BX55		
3	V-Belt						BX57	BX59
1	Regulator Assembly	115 VAC = asVPDB-AR-07						
		24 VDC = asVPDB-AR-03						
		24 VAC = asVPDB-AR-06						
1	Vacuum Breaker Valve Assy	VBV-BASE-NPT						
1	Motor Starter	Contact Factory - Parts@novatec.com						
1	Filter Element	hf-047	hf-047	hf-047	hf-047	hf-048	hf-048	hf-048
1	Regulator	50154						
1	Regulator Bracket	07-1397						
*	Lubrication Oil	Gardner Denver AEON PD-XD Lubricating Oil. NOVATEC P/N VPDB-QT and VPDB-CASE						

*See lubrication chart on page 11 to determine stocking level for oil.

NOTE: Parts shown are for standard VPDB series vacuum pumps. Refer to special job drawings for custom unit information. Verify information on existing part before ordering and installing replacement. All information is subject to change without notice.

9.0 OPERATING AT HIGHER ELEVATIONS

(3000 ft. above sea level or more)

Atmospheric pressure is lower at higher elevations and as a result, the compression of air by the pump requires more work for vacuum conveying. In these higher altitude applications, the pressure relief valve of VPDB pumps must be adjusted to prevent the pump from damaging itself or the motor by attempting to compress air of reduced density to an unsafe level. Failure to adjust the pump will void the pump warranty.

When the end-use site is known, Novatec endeavors to pre-adjust the vacuum pump's performance at the factory to compensate for elevations above 3000 feet. Novatec then labels the vacuum relief valve accordingly. If your pump-use site is 3000 feet above sea level or more, and no indication of pre-adjustment is present on the pump assembly, please contact Novatec Engineering or the Novatec Service Department at the number on the front cover of this manual to get instructions for adjusting your VPDB pump for use at elevations at 3000 feet or more above sea level.

11.0 MAINTENANCE AND INSPECTION SCHEDULE

It is recommended that maintenance and inspection is done on a scheduled basis. Maintenance requirements will naturally vary widely for each installation and specific operating conditions. It is suggested that a complete inspection be performed with the necessary maintenance at the end of the first day, the first week, the first month and the first 3 months. These inspections will be indicative of how often future maintenance will be necessary.

Every Week

Inspect the Filter cartridge. Clean or replace as required. Remove any fines collected from the catch pan. This time interval should be shortened if experience indicates unusual dust loading. Check the system for air leaks and correct as required.

Every Month

Inspect the vacuum breaker valve filter/silencer. Clean or replace as required.

If service to the vacuum breaker is required remove it from the filter housing.

Every 6 Months

Disconnect power and check for loose electrical connections. Tighten all bolts and nuts that may have

loosened due to vibration.

11.1 Belt Adjustment and Replacement

11.1.1 Inspecting V-Belts

1. Remove the pump from service and disconnect electrical power.
2. To inspect V-belts, remove the 2 bolts on ends of the belt guard (see figure 4). Carefully examine each belt for excessive stretch, looseness, frayed surfaces or exposed cord. Replace all belts if one or more belts are found to be excessively worn. Always replace belts as a set; never individually.
3. Inspect the belt tension (figure 5) using the specifications in the chart, below. Once belts are found in good condition and tensioned properly, replace the outside panel ensuring all 4 screws are fastened properly. Never operate the pump without the belt guard firmly installed.

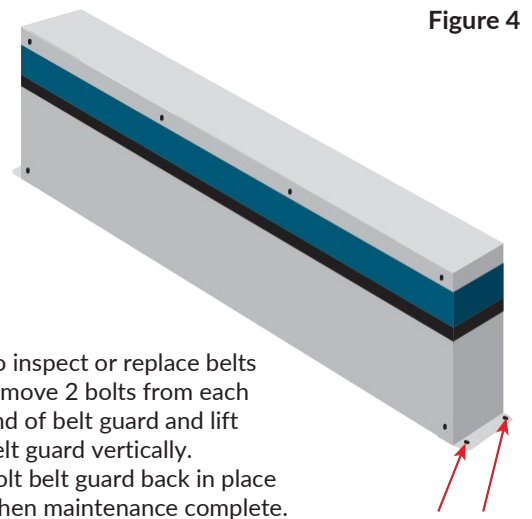
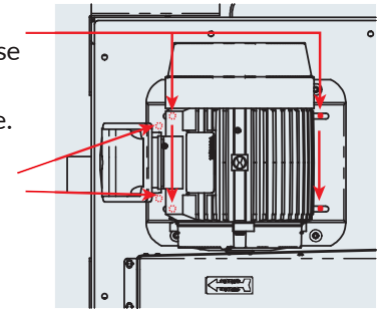

Figure 4

To inspect or replace belts remove 2 bolts from each end of belt guard and lift belt guard vertically. Bolt belt guard back in place when maintenance complete.

Typical both sides

Slightly loosen 4 each hex nuts on the motor base just enough to allow the motor to slide on the base. Use 9/16" wrench for 3 through 10 Hp units. Use 3/4" wrench for 3 through 10 Hp units.



Adjust 1 bolt on each side

of the motor base allowing the motor to slide, loosening or tensioning the belts.

Use 3/4" wrench for 3 through 10 Hp units.

Use 15/16" wrench for 15 and 20 Hp units.

Figure 5

Pump Model	Existing Belt Re-tensioning Pressure (lb.)	*New Belt Tensioning (lb.)	Belt Deflection at Pressure (jn.)
VPDB-3	3.4	5.1	0.31
VPDB-5	4.2	6.3	0.31
VPDB-7.5	3.6	5.4	0.31
VPDB-10	4.1	6.2	0.31
VPDB-10/3	4.1	6.2	0.31
VPDB-15	4.4	6.6	0.31
VPDB-20	4.6	6.9	0.34

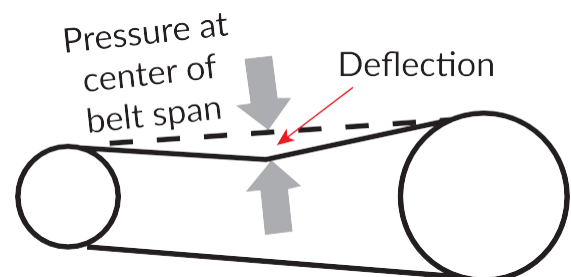

Figure 6

11.1.2 Replacing V Belts

If broken, stretched or excessively worn belts require replacement:

1. Remove the entire belt guard by removing the 4 bolts that connect the cover to the pump base (see figure 4, page 9), and lift the cover straight up.
2. Loosen the motor's mounting bolts and slide the motor base towards the pump, allowing the belts to loosen. Remove the belts (see figure 5, page 9).
3. Confirm use of the proper replacement belts (see parts list, page 8) and install them carefully onto each sheave pulley. All belts must be replaced as a set; never individually.
4. Re-tension the belts with the sliding motor base according to the chart (figure 6, see page 9). Note that new belts require greater initial tension than belts that have been in operation. Double check the belt tension while tightening the motor base and assure the motor stays in alignment while re-tightening (see figure 5, page 9).
5. Re-attach the belt guard ensuring the four mounting bolts are tight and locking washers are in place. Confirm that no part of the belt guard comes in contact with rotating sheaves or belts.
6. Reinstall the outside panel of the guard. All 4 bolts must be installed for safety. Never operate the pump without the belt guard firmly installed.

11.2 Special Note: Sheave Re-installation

In the event a new blower is fitted to your VPDB vacuum pump assembly, it is important to assure proper placement of the sheave on the pump's drive shaft. If not,

misalignment and unacceptable "overhang" can occur, prematurely wearing the seals and bearings of the pump.

Position of Sheave Pulley on VPDB Pump Drive Shaft:

CRITICAL NOTE:

On 3 and 5 Hp units: the bushing must be $1/32'' - 1/16''$ from the blower face. This will result in a $5/16''$ between the blower face and the sheave.

On the 10 through 15 Hp units: the bushing is held within the sheave. There should be $1/4''$ between the blower face and the sheave.

On the 20 Hp units: Position of Sheave Pulley on Pump Drive Shaft: The distance between the blower face and the installed pulley face must not exceed 0.38".

11.3 Cleaning Air-Filter

For your convenience the VPDB is equipped with a filter cartridge enclosed in a ClearVu cannister which allows you to know exactly when you need to clean or replace the filter element.



Filter Element in ClearVu Canister



Release clamps to remove ClearVu cannister. Pull cannister straight down and empty any dust.

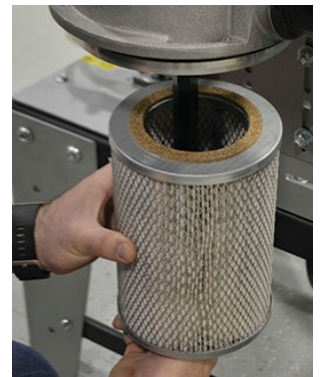

Pull filter straight down to clean or replace.

11.4 Removing Sound Curtains

If you have the optional sound curtain kit, panels can easily be removed for access to perform maintenance.



11.5 Blower Lubrication

Novatec VPDB Series vacuum pumps use horizontally installed Gardner Denver positive displacement blowers.

Gardner Denver recommends and Novatec uses:

Gardner Denver AEON PD-XD Lubrication or approved equivalent



NOVATEC P/N VPDB-QT (1qt.)
or P/N VPDB-CASE (12 qts.)

Lubrication Guidelines

- Novatec model MVP series vacuum pumps include splash lubricated bearings that require no grease, but both the gear and shaft sides of the pump unit contain oil sumps that must be maintained as part of your lubrication and oil replacement procedures.
- The lubrication should be changed after initial 500 hours of operation and then after every 1500 hours.
- The proper level should be in the middle of the sight gauge when the blower is not operating. **DO NOT OVERFILL OIL SUMPS** or damage to the blower may occur.
- The oil level may naturally rise and/or fall in the gauge during operation, but the oil level should not fall below the middle of the site gauge when the blower is idle.
- Routine "topping up" of oil levels is NOT advised. Each pump examination should include stopping the pump, allowing the oil level to stabilize and then checking the level in the sight glass windows before adding oil to the required level.

CAUTION:
DO NOT OVERFILL the pump with lubricant! Severe damage can occur, and warranty will be void.

Novatec VPDB Vacuum Pump Lubrication Capacities:

Pump Model	Shaft Side Oil Sump Capacity (oz.)	Gear Side Oil Sump Capacity (oz.)
VPDB-3	9.0	18.0
VPDB-5	9.0	18.0
VPDB-7.5	11.0	24.0
VPDB-10	11.0	24.0
VPDB-10/3	11.0	24.0
VPDB-15	19.1	40.0
VPDB-20	20.0	32.0

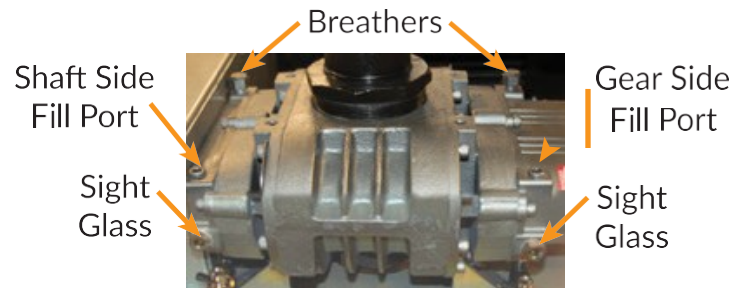

Oil levels should not be above or below centers of site glasses; oil levels will fluctuate when running.

Lubrication fill ports are located on the top of the blower. Sight glasses are located on the side of the blower. Oil level should be maintained up to the middle of the sight glass when the pump is idle. Be sure to maintain oil levels on both sides. Do not operate a pump with an insufficient lubricant level. Do Not Overfill.

E-Z Oil Drains Follow Label Directions to Open

Place container under drain and remove plug
Close valves and install plug after draining.



Place container under each drain. **Lift black tab to open valves.** Close valves when oil is drained.

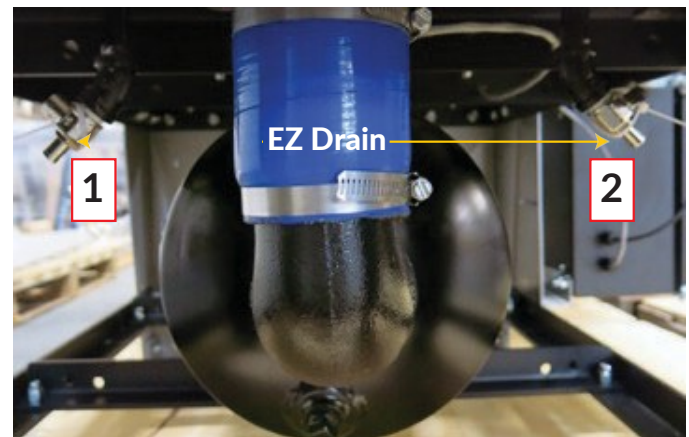

On VPDB-20, oil drains are located under the pump deck.

- Shaft Side:
- Gear Side

12.0 WIRING DIAGRAMS

24 VDC control voltage – typical for 380 and 460 voltages.

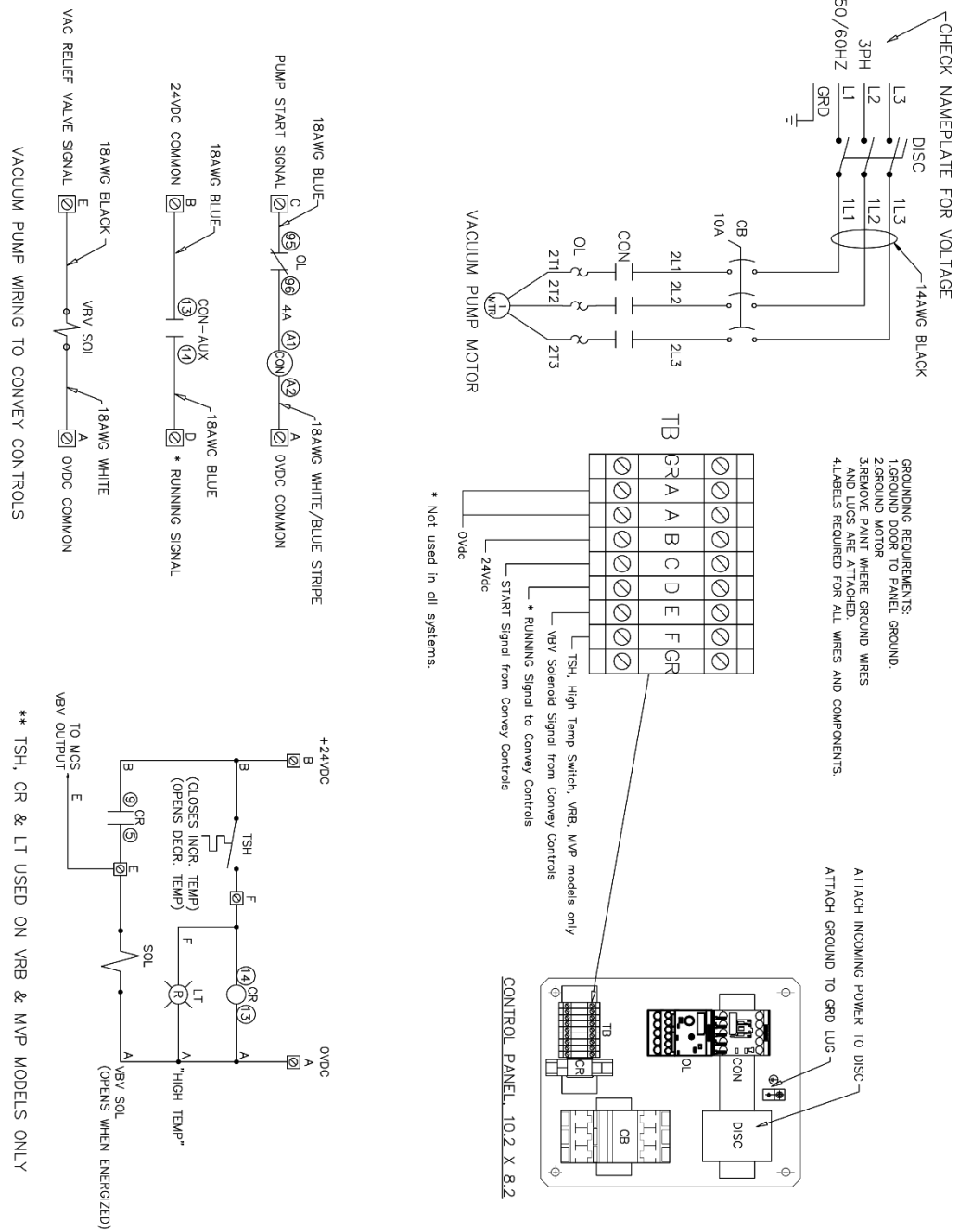

NOTE:
 Drawings provided are a generic representation of the VPDB Pump Series. Please reference the parts list for components applicable to your pump.

12.0 WIRING DIAGRAMS

115 VAC control voltage – typical for 380 and 460 voltages.

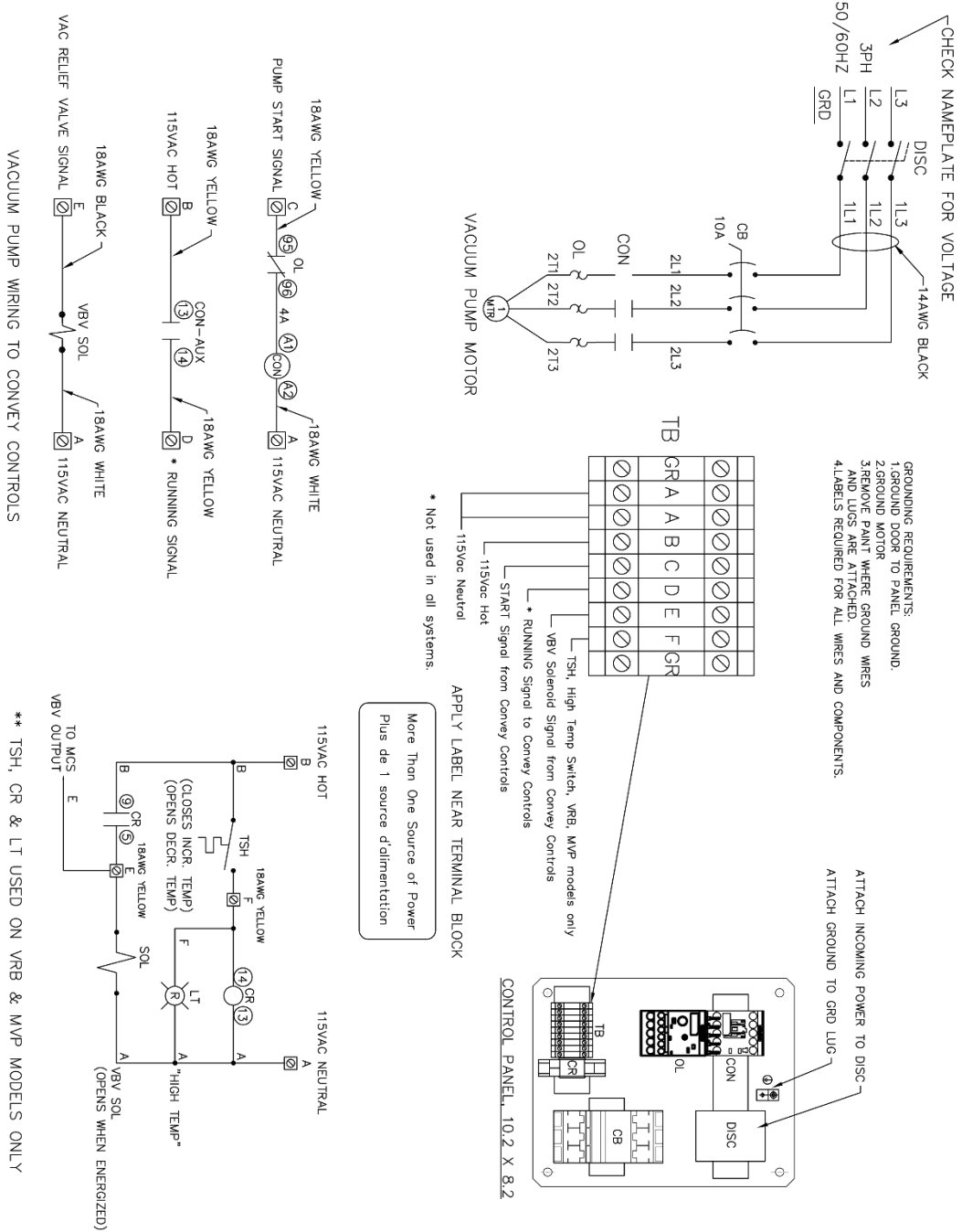

NOTE:
Drawings provided are a generic representation of the VPDB Pump Series. Please reference the parts list for components applicable to your pump.

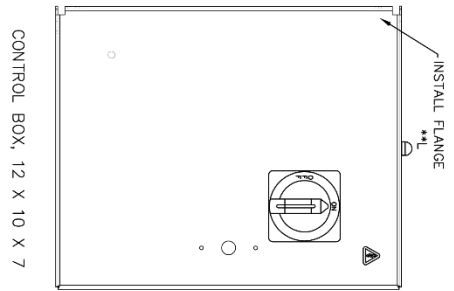

13.0 WARRANTY

NOVATEC, INC. - EFFECTIVE DATE 1 APRIL 2019

NOVATEC, INC. offers COMPREHENSIVE PRODUCT WARRANTIES on all of our plastic's auxiliary equipment. We warrant each NOVATEC man- ufactured product to be free from defects in materials and workman- ship, under normal use and service for the periods listed under "Warranty Periods". The obligation of Novatec, under this warranty, is limited to repairing or furnishing, without charge, a similar part to replace any part which fails under normal use due to a material or workmanship defect, within its respective warranty period. It is the purchaser's responsibility to provide Novatec with immediate written notice of any such suspect- ed defect. Warranted replacement parts are billed and shipped freight pre-paid. The purchaser must return the suspect defective part, freight prepaid and with identifying documentation to receive full credit for the part returned. Novatec shall not be held liable for damages or delay caused by defects. No allowance will be made for repairs or alterations without the written consent or approval of Novatec.

The provisions in equipment specifications are descriptive, unless expressly stated as warranties. The liability of Novatec to the purchaser, except as to title, arising out of the supplying of the said equipment, or

its use, whether based upon warranty, contract or negligence, shall not in any case exceed the cost of correcting defects in the equipment as herein provided. All such liability shall terminate upon the expiration of said warranty periods. Novatec shall not in any event be held liable for any special, indirect or consequential damages. Commodities not manufactured by Novatec are warranted and guaranteed to Novatec by the original manufacturer and then only to the extent that Novatec is able to enforce such warranty or guaranty. Novatec, Inc. has not authorized anyone to make any warranty or representation other than the warranty contained here. Non-payment of invoice beyond 90 days will invalidate the warranty. A renewed warranty can be purchased directly from Novatec.

Please note that we always strive to satisfy our customers in whatever manner is deemed most expedient to overcome any issues in connection with our equipment.

Warranty Periods:

Note: All warranty periods commence with the shipment of the equipment to the customer.

5-YEAR (Except 1-Year on Non-Novatec Buy-Out Items)

Resin Drying to Include:

NovaWheel™ Dryers *
Dual Bed Dryers
NovaDrier *
NDM-5 Membrane Dryer
Gas-Fired Process Heaters
Gas-Fired Regeneration Heaters
Drying Hoppers
Central Drying Hopper Assemblies
Heater/Blower Units and Hot-Air Dryer
Silo Dehumidifiers
NovaVac Dryers *
Nitrodry Nitrogen Dryers
DryTemp Plus

Central System Controls to Include:

FlexTouch™ Series Controls
FlexXpand™ Series Controls
OptiFlex™ Series Controls
PLC Communications Modules
Greenboard Communications Modules
LOGO! Mini PLC
MCS-600 Series Controls - (Distributed I/O)
MCS-400 Series Controls
CL Silo Manager

Moisture Measurement Equipment to Include:

MoistureMaster®

PET Resin Crystallizers

Resin Blending and Feeding to Include:

WSB Blenders, MaxiBatch & Feeders *
Gaylord Sweeper Systems

Downstream Extrusion Equipment to Include:

C and NC Bessemer Series Cutters
NPS Bessemer Series Pullers
NPC Mini Puller/Cutter
All NS Series Servo Saws
Rx SmartMed Extrusion Products
All Cooling and Vacuum Tanks Manufactured by Novatec

Resin Conveying and Systems Components to Include:

GSL Series Vacuum Loaders
GlassVu Loaders, Receivers and Hoppers
VL/VLP Series Loaders
VRH, VR, VR-FL, VRP & VRM Series Receivers
Compressed Air Loaders
AL-B Barrel Loader
Cyclone Dust Collectors
Conveying System Accessories
Surge Bins
Valves and Accessories
Electronic Metal Separators
Quick Select Manifolds
Tilt Tables
Filter Dust Collectors
Drawer Magnets
Velocity Control Valves

3-YEAR

Resin Conveying System Components to Include:

** VPDB Vacuum Positive Displacement Pumps
** SVP Vacuum Pumps
** MVP Vacuum Pumps
** Railcar Unloading Systems

****5-Year Extended Warranty** - When a MachineSense® data plan is activated for products with **, Novatec automatically extends the warranty to 5 years. The data plan must be activated within 60 days after product shipment and remain active through the warranty period to maintain extended warranty eligibility. The first 6-months of data plan usage is free from Novatec.

1-YEAR

Infrared Dryers
UltraVac Vacuum Pumps
Vacuum Regenerative Blower Pumps
Custom Equipment of any kind unless otherwise specified

Exclusions:

Routine maintenance/replacement parts are excluded from the warranty. These include, but are not limited to: hoses, desiccant, filters, filter elements, wiper seals, gaskets, dew point sensors, infrared lamps, motors, internal solenoids, fuses and motor brushes. Use with abrasive materials will void the warranty of any standard product. Wear resistant options may be available to extend usable service life with abrasive materials. Novatec reserves the right to limit the warranty if the customer installs replacement parts that do not meet the specifications of the original parts supplied by Novatec.

***Specific Exclusions:**

1. NovaDrier™ and NITROdry™ warranty is void if coalescing filters are not replaced on a 6-month or yearly basis (per instruction manual) and/or membrane has been exposed to ozone.
2. NovaVac Dryer -The ability of the canisters to hold vacuum will be compromised if the vacuum seal edge is damaged from mishandling. We do not warranty canisters damaged from improper handling. We do, however, warranty the seals.

LOAD CELLS on our WSB's are covered by Novatec standard warranty as long as they have not been damaged from improper handling.

3. Desiccant Wheel Warranty will be void if the wheel has been exposed to plasticizer, dust or other contaminants as a result of negligence on the part of the processor.
4. DryTemp+ - We assume no responsibility from equipment failures resulting from untreated or improperly treated water.

This warranty shall not apply to equipment:

1. Repaired or altered without written approval of NOVATEC unless such repair or alteration was, in our judgment, not responsible for the failure
2. Which has been subject to misuse, negligence, accident or incorrect wiring by others
3. Warranty is void if processing rates exceed manufacturer-recommended levels or if damage is caused by ineffective power isolation and/or power spikes/sags or incorrect installation.

NOTE: All conditions and content of this warranty are subject to changes without notice.

Drying > Conveying > Blending > Downstream



222 East Thomas Avenue
Baltimore, Maryland 21225

www.novatec.com

Phone

410-789-4811 or 800-938-6682

24 Hour service: 800-938-6682

Fax: 410-789-4638

Email

Parts: parts@novatec.com

Service: service@novatec.com

Sales: sales@novatec.com