

Vacuum Receivers VR and VRP Series

Models: VR-5, VR-8, VR-12, VR-19, VR-38, VR-76, VR-114
VRP-12, VRP-19, VRP-38, VRP-76



VR Series
Pellet/Regrind
Receivers



VR-MM
Series
Receivers



VRP Series
Powder
Receivers

© NOVATEC, Inc. 2018 All Rights Reserved

Document: VR-VRP IM 9 FEB 2018



Novatec, Inc. 222 E. Thomas Ave. Baltimore, MD 21225 | www.novatec.com

Phone: 410-789-4811
Toll Free: 800-938-6682
Main Fax: 410-789-4638

Parts Email: parts@novatec.com
Service Email: service@novatec.com
Sales Email: sales@novatec.com

NOTES:

Please record the following information, which is specific to this piece of equipment, in the space provided. Our Parts/Service Department will need these numbers to properly respond to any of your requests.

Instruction Manual: VR-VRP IM 9 FEB 2018
Model #: _____
Serial # _____

<p>DISCLAIMER: NOVATEC, Inc. shall not be liable for errors contained in this Instruction Manual nor for misinterpretation of information contained herein. NOVATEC shall not, in any event, be held liable for any special, indirect or consequential damages in connection with performance or use of this information.</p>
--

FOREWORD

This manual is dedicated to the principle that any engineered system will have many elements contributing to the smooth operation of the system, and that these must be understood in order that installation and operation can proceed successfully.

The electrical and mechanical components in the GSL Series loaders have been manufactured, selected and assembled with care to give you excellent service. All components of your GSL loader have been carefully engineered and manufactured and have been thoroughly inspected for quality, function and performance.

Before installing this system, please read this manual, review the diagrams and the safety information. This should save valuable installation and operation time later and will help ensure safe operation and long life.

Table of Contents

1-UNPACKING AND INSPECTION.....	4
2-BASIC FUNCTIONS OF VACUUM RECEIVERS.....	4
2.1 NOVATEC VR SERIES RECEIVERS.....	4
2.2 NOVATEC VRP SERIES RECEIVERS.....	4
2.3 OPTIONS & ACCESSORIES.....	4
3.0 SPECIFICATIONS.....	5
3.1 VR Series Vacuum Receivers.....	5
3.2 VRP Series Vacuum Receivers.....	7
4-PRINCIPLE OF OPERATION-VACUUM SYSTEMS.....	8
5-PRINCIPLE OF OPERATION-VACUUM RECEIVERS.....	9
6-RECEIVER INSTALLATION.....	10
6.1 VACUUM BREAKER “T” VALVE INSTALLATION.....	11
7-VRP SERIES RECEIVER COMPRESSED AIR INSTALLATION.....	11
8-DEMAND LEVEL SWITCH WIRING.....	12
9-INITIAL START UP.....	13
9.1 VR (PELLET/REGRIND) RECEIVERS:.....	13
9.2 VRP (POWDER) RECEIVERS:.....	13
10-USE OF PROPORTIONING VALVES.....	14
13-MAINTENANCE.....	16
13.1 VR Series - FLAT SCREEN FILTER CLEANING:.....	16
13.2 CARTRIDGE FILTER CLEANING.....	17
13.3 WASHING CARTRIDGE FILTERS.....	18
13.4 DRYING THE CARTRIDGE:.....	18
14-TROUBLESHOOTING.....	19
14.1 PROBLEM: POOR OR NO CONVEYING:.....	19
15-WARRANTY.....	22

1-UNPACKING AND INSPECTION

After receipt of the unit, completely inspect it for damage. Although the units are packaged securely, vibration and mishandling during transit can cause damage.

Since receivers are part of a system and do not operate alone, examine carton carefully for accessories, wiring and spare parts that may have been included in the shipment. Check inside chambers for parts and shipping materials.

2-BASIC FUNCTIONS OF VACUUM RECEIVERS

NOVATEC VR and VRP Series vacuum receivers are vessels for the receipt of materials conveyed by a vacuum loading system consisting of a central vacuum pump, a control system and interconnected vacuum tubing.

Each unit is designed to operate within a specifically pre-engineered central vacuum system and must be matched to the line size of the system (tubing diameter), control voltage and throughput capability. Each receiver must be accompanied by a range of accessories for its operation. These components are purchased separately.

- control system
- vacuum breaker, or "T" valve
- tubing, bends, couplers and flex hose of the correct diameter for the vacuum system
- tubing, bends, couplers and flex hose of the correct diameter for material conveying

2.1 NOVATEC VR SERIES RECEIVERS

NOVATEC VR Series receivers are designed to receive virgin pellets and regrind materials vacuum conveyed to them from storage containers and are typically located over drying hoppers, blenders and process machines. VR series receivers are usually equipped with screen disc filters that permit the passage of dust and fines, but hold the virgin/regrind in the receiver chamber.

Machine Mount versions are available for both the VR series to load material directly into the machine throat.

2.2 NOVATEC VRP SERIES RECEIVERS

NOVATEC VRP Series receivers are designed to receive free flowing powders and are frequently used on extrusion processes. VRP receivers are equipped with high capacity filter cartridges and a blow down system designed to extend the operational life of the filter cartridges and keep *all* conveyed material, dust and fines within the receiver chamber.

2.3 OPTIONS & ACCESSORIES

VR Options include:

- Alternate line sizes
- Alternate control voltages (in lieu of 24 VDC)
- DeviceNet Cables for 24 VDC
- High Heat Packages for materials above 225°F
- Alternate Glass Hopper Sizes (for VR-MM models)

VR Accessories Include:

- Proportioning valves
- Capacitance Level Switch
- Pulsed Blowback Control
- Field Conversion Kits for Larger Glass Hoppers

VRP Options Include:

- Alternate line sizes
- Alternate control voltages (in lieu of 24 VDC)

VRP Accessories Include:

- Pulsed Blowback Control

3.0 SPECIFICATIONS

3.1 VR Series Vacuum Receivers

Model	Configuration	Volume		Capacity*		Line Size	
		ft ³	liters	lb	Kg	in	mm
VR-5	Standard	1/25	1.1	1.5	0.7	1.5, 2, 2.5	38, 50, 64
VR-5-B	Blowback †						
VR-5-MM	Machine Mount †						
VR-8	Standard	1/5	5.7	8	3.6	1.5, 2, 2.5	38, 50, 64
VR-8-B	Blowback †						
VR-8-MM	Machine Mount †						
VR-12	Standard	1/3	9	12	5.4	1.5, 2, 2.5, 3.0	38, 50, 64, 76
VR-12-B	Blowback †						
VR-12-MM	Machine Mount †						
VR-19	Standard	1/2	14	19	8.6	1.5, 2, 2.5, 3.0	38, 50, 64, 76
VR-19-B	Blowback †						
VR-19-MM	Machine Mount †						
VR-38	Standard	1	28	38	17.2	1.5, 2, 2.5, 3.0	38, 50, 64, 76
VR-38-B	Blowback †						
VR-38-MM	Machine Mount †						
VR-76	Standard	2	56	76	34.5	2, 2.5, 3, 4	50, 64, 76, 102
VR-76-B	Blowback †						
VR-114	Standard	3	84	114	51.7	2, 2.5, 3, 4	50, 64, 76, 102
VR-114-B	Blowback †						

* Resin capacity based on 38 lb/ft³ bulk density.
 † 24VDC standard - 115V is a no charge option.

Accessories:

Pulsed Blowback Control:

Mini-PLC control mounts near receiver and generates adjustable blowback signals when the central control is not equipped with the blowback feature.

External Proportioning Valve with Coupler:

Available for all receivers. (See separate data sheet)

Proportioning Valve Control:

Mini-PLC control mounts near receiver and generates adjustable proportioning signals when the central control is not equipped with proportioning capability. Utilizes the receiver's load signal.



Retrofit Glass Hopper Sizes for Existing MM Units:

(In lieu of 2 lb) Field conversion kit includes base, glass, top adapter plate and discharge valve. 8, 12, or 16 lb glass.

Station "T" Sequencing Valve:

Required for all receivers. (See separate data sheet)

Level Switch, Capacitance:

30mm diameter, 2m cable - Available for all receivers.

Options:

Must Specify JIT Glass Hopper Size - MM Units

2 lb standard on -8-MM, -12-MM and -19-MM (8,12, and 16 lb optional)
 16 lb standard on VRH-38-MM (8 and 12 lb optional)
 Note: 2 lb glass not available on VRH-38

DeviceNet Cables for All Models:

(in lieu of standard cables, 24VDC only)

High Heat Packages for Discharge, Filter Assemblies and Inlet Check Valve:

(For temps above 250°F) (See price list 315)

Custom Drilling of MM Flange:

(Standard base flange is blank for customer drilling.)

Extended Wear Package for VR-5, through VR-114 Models Includes:

- Removable ceramic lined inlet (N/A on VR-5 and VR-8)
- Ceramic coated inlet flapper check valve
- Removable ceramic coated impact wear plate
- SS Discharge flapper

Ceramic lined inlet diameters available

- VR-5, VR-12 and VR-19 (1.5" - 2.5")
- VR-38 and VR-76 (1.5" - 3")
- VR-114 (2.5" - 4")

(See price list 315)

Dimensions and Weights

Hopper Loading Packages										
Part Number	A		B		C		D		Shipping Wgt.	
	in	cm	in	cm	in	cm	in	cm	lb	Kg
VR-5	18	46	11	27	4.3	11	6	15.2	25	11
VR-8	29	74	22	55	13.2	33.5	6	15.2	29	13
VR-12	24	62	18	45	10.6	22	10	25	40	18
VR-19	28	72	22	55	14.6	37	10	25	45	21
VR-38	34	86	25	63	17.7	45	16	41	55	25
VR-76	43	109	35	88	27	69	16	41	65	30
VR-114	42	107	34	87	25	64	24	61	120	55

Mounting Patterns

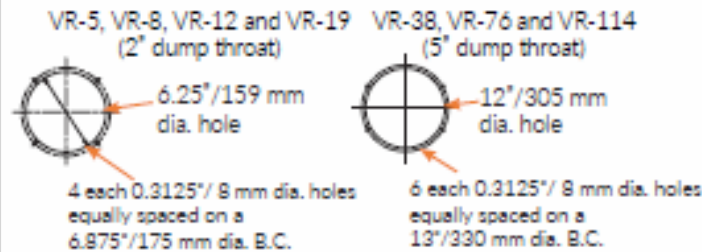

Machine Mount Packages (2 lb Glass)									
Part Number	A		B		D		Shipping Wgt.		
	in	cm	in	cm	in	cm	lb	Kg	
VR-5 MM	22	56	15.6	39.6	6	15.2	30	14	
VR-8 MM	33	84	24.5	62	6	15.2	34	16	
VR-12 MM	28.6	72.6	22	56	10	25	45	21	
VR-19 MM	32.6	82.8	26	66	10	25	50	23	
VR-38-MM	37.9	92.3	30.7	78	16	4.6	60	28	

NOTE: 8 lb glass: add 3.7" to A and B, 12 lb glass: add 7.7" to A and B, 16 lb glass: add 10.7" to A and B. (2 lb glass n/a on VR-38) (See options page 3)

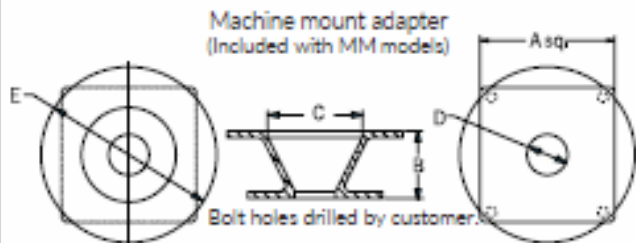

Machine Mount Adapter Dimensions												
Glass Size lb/Kg	Model	A		B		C		D		E		
		in	cm	in	cm	in	cm	in	cm	in	cm	
2/0.9	VR-5, -8, -12, -19	5	12.7	2.5	6.4	3.5	8.9	1.5	3.8	6.5	16.5	
2/0.9	VR-MM-F65*	6.5	16.5	2.5	6.4	3.5	8.9	2.25	5.7	6.5	16.5	
Varies	VR-MM-8, -12, -16**	6	15.2	5.7	14.5	8	20.3	2	5.1	10	29.2	

* Optional 2 lb glass adapter dimensions
** Optional large glass adapter dimensions

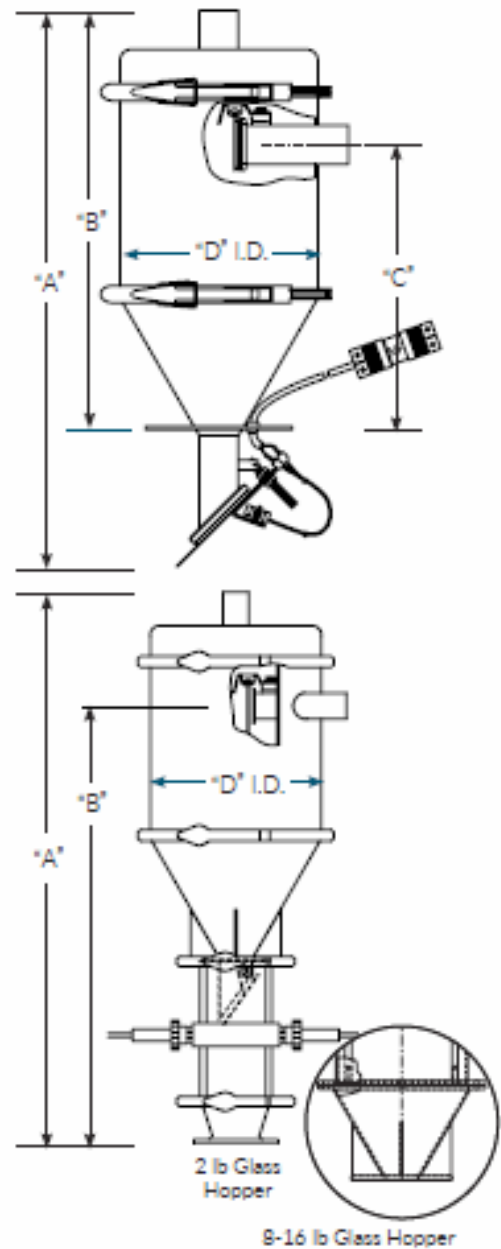

3.2 VRP Series Vacuum Receivers

Overall Dimensions and Weights								
Model	A		B		C		D	
	in	cm	in	cm	in	cm	in	cm
VRP-12	35	89	28	71	11	28	10	25
VRP-19	39	99	32	81	14	36	10	25
VRP-38	54	137	46	117	17	43	16	41
VRP-76	64	162	56	142	27	69	16	41

Part Number	VRP-12		VRP-19		VRP-38		VRP-76	
Characteristic	U.S.	Metric	U.S.	Metric	U.S.	Metric	U.S.	Metric
Volume	1/3 ft ³	9 liters	1/2 ft ³	14 liters	1.0 ft ³	28 liters	2 ft ³	57 liters
Resin Capacity	12 lb	6 Kg	19 lb	9 Kg	38 lb	17 Kg	76 lb	34 Kg
Discharge Diameter	2 in	51 mm	2 in	51mm	5 in	127mm	5 in	127mm

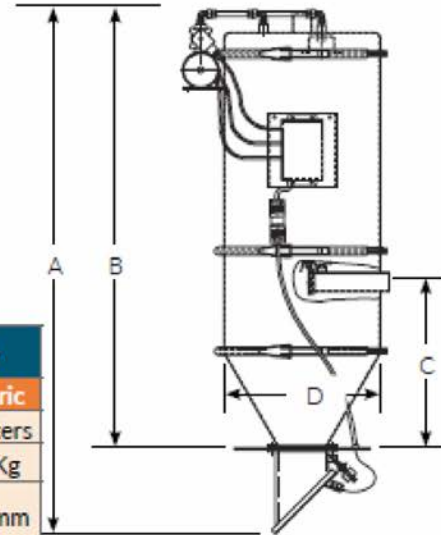

Mounting Patterns

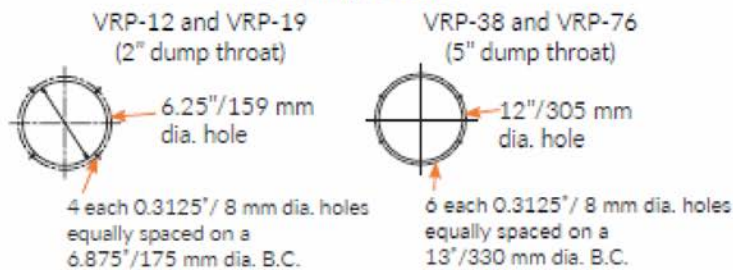

Options:

Alternate Line Size: No Charge			
VRP-12	VRP-19	VRP-38	VRP-76
Line Size	Line Size	Line Size	Line Size
2.5"	2.5"	2.0"	2.0"
	3.0"	3.0"	3.0"
(in lieu of 2.0")	(in lieu of 2.0")	(in lieu of 2.5")	4.0"
			(in lieu of 2.5")
Alternate Control Voltage: 115/1/60Hz (in lieu of 24 VDC) No Charge (For all models)			

Extended Wear Package with Removable Inlet for All Models

Includes:

- Ceramic lined removable inlet (1.5 - 3" O.D.)
- Ceramic coated inlet flapper check valve
- Ceramic coated impact wear plate
- SS Discharge flapper

Accessories:

Valves & Valve Controls (See price list # 360)

Pulsed Blowback Control: 24 VDC or 115/1/60. Requires connection to the 24 VDC (or 115 if using 115 volt power at the receiver or loader, plus load signal)

Air Evacuation Sub-base: For VRP-12 through VRP-76.

Notes:

- An optional Air Evacuation Filter Sub-Base should be included if the receiving hopper is not already vented and filtered.
- An optional pulsed blowback control may be added if the loading control is not equipped with blowback capability.
- A proportioning valve option may be easily added to any model to allow proportional loading (by time) of two materials (usually virgin and regrind).
- A vacuum "T" sequencing valve, purchased separately, is required for each receiver when multiples are used in a system.
- Material/vacuum line size and control voltage must be specified.

4- PRINCIPLE OF OPERATION-VACUUM SYSTEMS

NOVATEC central vacuum conveying systems utilize a powerful vacuum pump to create vacuum conveying power for a number of receivers. Receivers are interconnected with the vacuum pump via tubing and a control system. Each receiver in the system has the ability to use the central pump for vacuum conveying power within a sequencing arrangement...one receiver at a time. The selected conveying control system in use determines the sequence of operation and triggers vacuum isolation valves, known as vacuum breaker or “T” valves, located near each receiver, one at a time, to allow vacuum to flow to each receiver with a demand for a set period of time. After that receiver loads, the vacuum signal is passed onto another receiver with vacuum demand, allowing it to load.

Vacuum systems typically employ a central dust collector, located near the vacuum pump. The dust collector allows material fines and dust that are carried through from each receiver to be trapped, before they are allowed to enter the pump. VR receivers are typically equipped with only screen filters, freely allowing dust and fines to pass through and be trapped by the central dust collector. In this regard, users find efficiency in two ways:

1. The conveyed materials are somewhat ‘stripped’ of dust and fines by the vacuum system. These fines typically provide little value and/or actually detract from the molding process.
2. The maintenance required for the filter medium is greatly reduced and is more conveniently located at floor level, near the pump.

VRP receivers are not equipped with flat screens, but very fine cartridge filters that trap all of the material, dust and fines being conveyed.

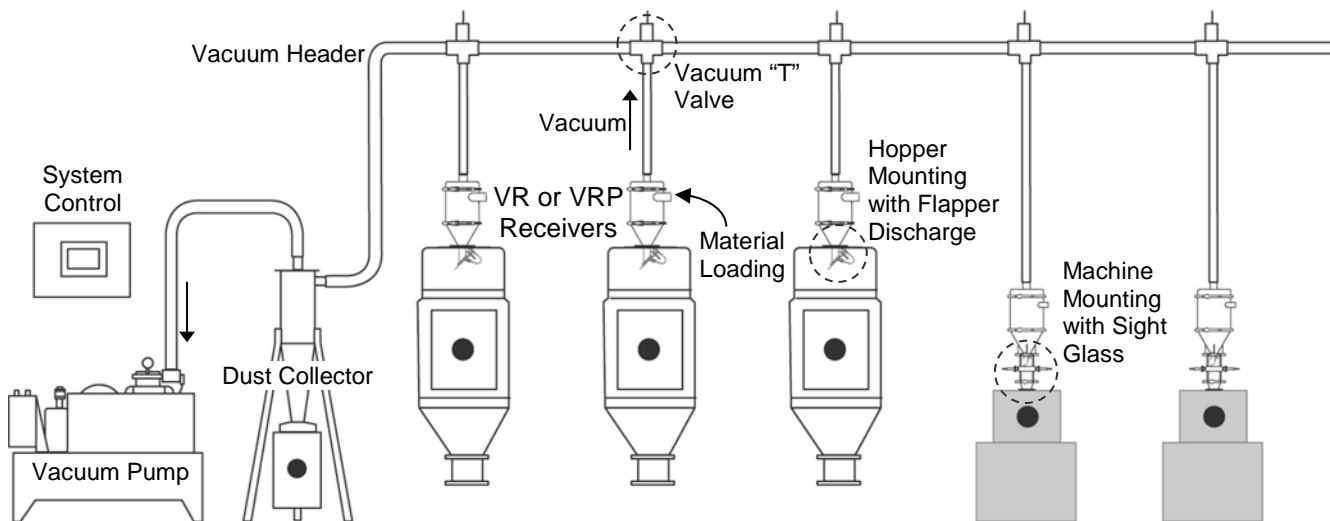

5-PRINCIPLE OF OPERATION-VACUUM RECEIVERS

Each receiver is equipped with a material level switch that signals the control system with a 'demand' for vacuum power from the central pump to load. The switch may be a tilt switch, located on the flapper valve below each receiver or in the form of an electric eye that can sense the presence or absence of material in a sight glass below the receiver. The switch is designed to signal a lack of material and the need, or demand, for the material supply to be replenished.

Inlet check valve
inside receiver

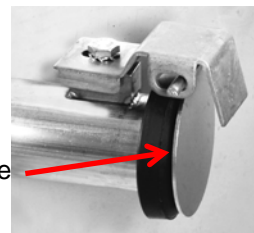

The control system will receive the demand signal from the receiver and when it is able, send a signal to that receiver station, allowing it to load. The receiver station is equipped with a vacuum breaker that will open, allowing vacuum power to enter only that receiver, creating suction to pull its discharge flapper valve shut and pull material to the receiver from the selected material source. As material is pulled into the receiver vessel, it passes through a check valve on the receiver inlet and the receiver's chamber fills. The vacuum air used for this process is drawn through the filter media of the receiver back towards the central pump for the time setting established on the central control for that receiver. The filter media blocks the loaded material from entering the vacuum line that exits the receiver.

Once the load time setting expires, the central control turns off its signal to that receiver, allowing the vacuum breaker valve to close, shutting off the vacuum supply to that receiver. While the control system directs the vacuum signal to move on to other receivers in the system, the loaded receiver, no longer under the negative pressure of vacuum, gravity unloads its material into the vessel or machine below it. At this point VRP receivers are triggered to blowback their cartridge filters with compressed air, cleaning off collected dust and fines. The check valve installed on the material inlet of the VRP, now closed, blocks the flow of the blow down air from entering the material conveying line. VR receivers are not equipped with the blowback feature.

Material discharges from the chamber by gravity and flows to its destination (dryer, blender, machine). If the loaded material completely evacuates the chamber and does not back up into the receiver, the process will repeat. This is the result of the discharge flapper on the base of the receiver, which is pushed open by the discharged material, swinging back by gravity towards closing after material is unloaded. The flapper's demand switch will indicate a new demand to the central control. If material does back up into the receiver, it will not allow the discharge flapper to swing shut. This will stop the demand switch on the flapper from sending another demand signal to the control. Once material drifts away from the flapper, the flapper will swing by gravity towards closing and once again create a demand signal.



Counter-weighted flapper
discharge valve with tilt
demand switch.

Machine mounted units do not require a flapper valve or demand tilt switch, but instead utilize a clear sight tube, which mounts vacuum-tight to the machine throat, with a sensor to control loader operation based upon the level of material within the sight tube. In many cases, a redundant, vacuum-sealing flapper is added to the sight glass, to assure a vacuum tight seal for loading. The sensor used on machine mount sight glasses may be a capacitance type, with a sensitivity adjustment, set against the glass, or a pair of photoelectric sensing elements called an emitter and a receiver that send a signal through the glass. In either case, the function is similar to the flapper tilt switch in the way it signals the central control system when material is not present and that the receiver requires loading. Note that a sensor on the sight glass may be vertically adjustable for different levels of material in the sight glass, IE: The user can adjust at what level the receiver will call for more material.



VR-MM Machine Mount with photo-eye demand switch.

6-RECEIVER INSTALLATION

Mount the receiver body to the hopper lid, positioning it so that the material inlet is directed towards the material pick up point or conveying line. Make sure the dump valve flapper has enough room to move freely. Secure the receiver to the hopper lid with captive bolts or clamps to ensure a safe installation with no chance of hardware vibrating loose. Ensure a tight seal when securing the loader to the hopper or machine. This is particularly important for VRP units that will be conveying powder.

On machine mounted units, the bottom flange is usually supplied undrilled to allow a range of mounting patterns and hardware choices. A gasket is used to provide a tight seal between the receiver base and the machine throat.

Conveying lines should be installed horizontal and/or vertical, using a 90 degree radius bend for directional changes, and it should be as direct as possible with no slope. All connections must be vacuum tight. Rigid conveying tubing should be properly supported by the installer to provide a safe and secure installation. Use flexible material handling hose to connect the material pick-up lance or vacuum take-off box to the conveying line. The flexible hose should be only as long as needed, since excess hose will reduce loader efficiency and is prone to rapid wear.

6.1 VACUUM BREAKER “T” VALVE INSTALLATION

Each receiver in the vacuum loading system requires a vacuum breaker valve to be connected to it, which in turn is connected to the central vacuum header coming from the vacuum pump/dust collector. The header typically interconnects several receivers with the vacuum pump. See separate instructions for vacuum breaker valve installation. The vacuum breaker valve is the key device for directing vacuum power to the receiver for operation. On VR series receivers, the vacuum breaker valve is the only electrical/pneumatic device associated with the receiver, unless other options are employed. The valve requires a connection to clean and dry compressed air, between 80 and 125 psi. The valve also requires electrical connection to the control system being used. See the central control instructions to assure that the solenoid on the vacuum breaker valve is the proper voltage and for connecting the valve solenoid coil to the control system.

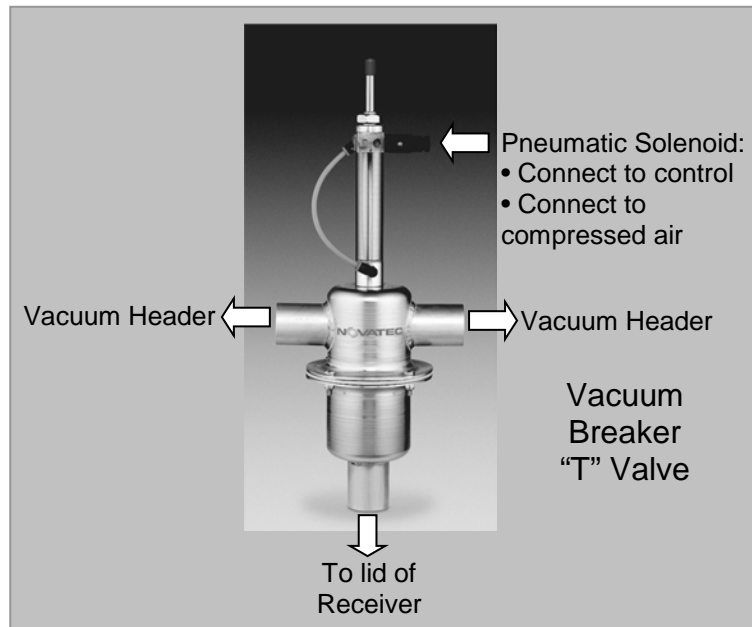

Connect the vacuum breaker valve to the lid of the receiver as described in the vacuum breaker valve instructions. Depending upon the installation, the valve to receiver connection can be a combination of tubing and flex hose as required, but should be kept as short as possible. The final connection to the lid of the receiver should be provided with flex hose to allow easy removal of the receiver lid for cleaning and maintenance.

7-VRP SERIES RECEIVER COMPRESSED AIR INSTALLATION

VRP series receivers include an on-board compressed air filter blowback system consisting of an accumulator, solenoids, and cartridge filters inside the receiver. Connect a clean, dry compressed air supply line to the accumulator tank. The minimum requirement for effective filter cleaning is 80 PSI. Do not exceed 125 psi. A flexible connection is often desired for this connection since movement of the accumulator section is often required for effective cleaning and maintenance of the receiver. Utilizing a non-restricting quick disconnect will allow full removal of the receiver if necessary.



8-DEMAND LEVEL SWITCH WIRING

Each receiver is equipped with a demand level switch that must be connected to the central control system. The switch may be in the form of a tilt switch on the discharge flapper valve, a capacitance sensor or rotating level switch, located in a bin below the receiver, a photoelectric switch on the sight glass of a machine throat receiver, or some other form. In all cases, this demand switch is required to tell the central control system when this receiver is in need of material. Since the receiver may be moved occasionally for cleaning or equipment changes, NOVATEC provides most demand switches with twist-lock connectors, allowing the receiver to be removed while the wiring to the control to can remain intact. This robust connector provides a reliable connection point for wiring to the control.

The following illustrations show 24 VDC wiring details for common NOVATEC demand devices. Use these illustrations in conjunction with the wiring instructions for your central controls to carefully connect the demand switches to your control system.

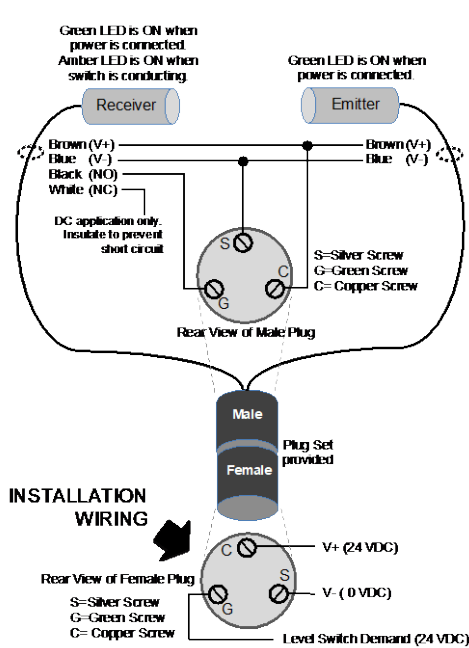

Typical Photo-eye Demand Switch

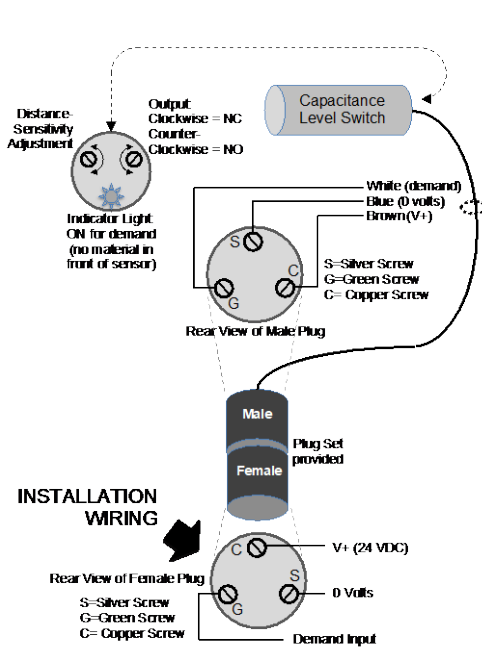

Typical Capacitance Demand Switch

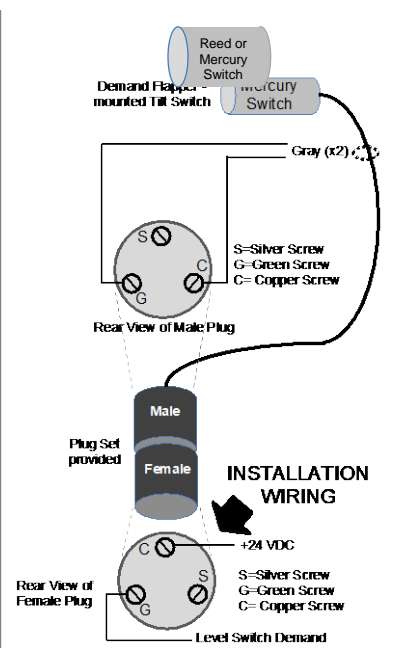

Typical Discharge Flapper Tilt Demand Switch

CAUTION: Follow All Plant Wiring Formats and Local or National Electrical Codes.

9-INITIAL START UP

9.1 VR (PELLET/REGRIND) RECEIVERS:

For optimum receiver operation, adjust the vacuum-on load time on the central control so that the vacuum chamber is almost completely full at the end of the load cycle. **Do not allow the chamber to overflow.**

Adjust the dump time so that it is only 1 to 2 seconds longer than the time necessary to completely empty the chamber.

9.2 VRP (POWDER) RECEIVERS:

For optimum receiver operation, adjust the vacuum-on load time at the central control so that the lower vacuum chamber is almost completely full at the end of the load cycle. VRP series powder receivers include an extended body to house the cartridge filters. Loaded material should not be allowed to be filled up into this extended hopper area. It is intended only as a housing for the filter cartridges, not a high capacity hopper for collecting loaded material. **Do not allow the chamber to overflow.**

Adjust the dump time so that it is only 1 to 2 seconds longer than the time necessary to completely empty the chamber. Coordinate dump time with the blowback cycle (see below) to assure that the bulk of loaded material has evacuated the chamber efficiently, while filters are being cleaned.

The number of blowback pulses needed to clean the filter cartridges depends upon the material being conveyed. Free-flowing, unblended powder will require minimal filter cleaning while heavily loaded, blended powders may necessitate the maximum filter cleaning sequence to keep the cartridges free of accumulation and allow longer operational life between manual cleanings and/or replacement. Refer to the instructions accompanying the specific filter-cleaning blowback control being employed for adjustment instructions. Adjust the pulse cycle so the filters remain clean. A mid-range setting is suggested as a starting point.

Note that during discharge and blowback, the check valve inside the VRP receiver should swing shut by gravity, preventing blowback air from flowing down through the conveying line and possibly ejecting dust into the atmosphere at the feed tube or take off box. If dusting is experienced out of the material conveying line, decrease the load time to prevent the check valve from becoming jammed with loaded material, which can prevent it from closing, when vacuum is removed.

10-USE OF PROPORTIONING VALVES

Proportioning valves are a convenient method for introducing regrind into the process while vacuum loading of virgin material. The proportioning valve is typically installed onto the material inlet of the receiver and is connected to the central control system, or an accessory control specifically designed for proportioning valve operation.

Note that a proportioning valve should never be relied upon for *accurate* mixing of two materials, but are only a process convenience for loading a second material (typically regrind). An ideal use of a proportioning valve is emptying a granulator of reground material, in quantities known to not exceed the limitations or specifications of the process. If requirements for the proportioning valve require more accuracy, consult with NOVATEC regarding the use of a blender in lieu of a simple proportioning valve.

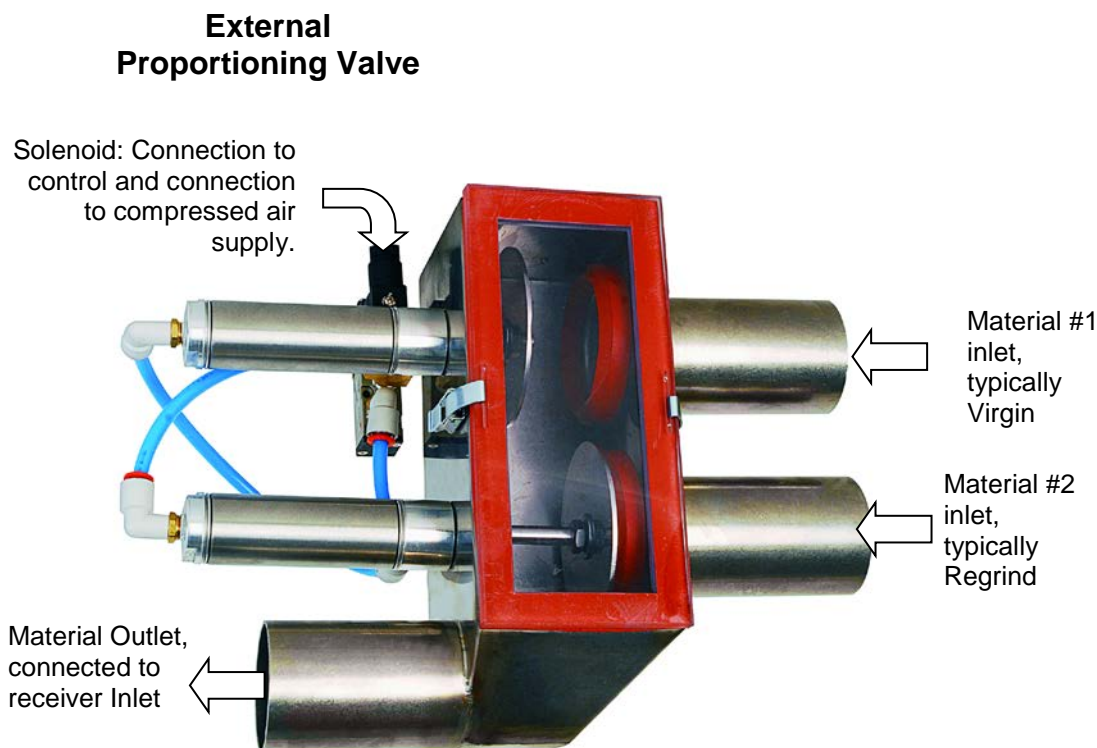

Proportioning valves and their associated controls split the central control's vacuum-on time for a particular receiver into two parts: one for loading virgin and one for loading regrind.

Making initial settings for the proportioning valve will require:

1. Determining and setting the approximate percentage of vacuum on time to be dedicated to regrind loading, based upon the specs of the product being produced.
2. Depending upon the control being used, determining and setting the approximate percentage of vacuum on time to be dedicated to virgin loading.
3. The number of valve switches (virgin/regrind/virgin/regrind, etc.) the valve will perform while vacuum loading, to encourage "mixing" of the two materials.
4. Increasing the vacuum-on time to compensate for use of the proportioning valve.

Be aware that use of a proportioning valve will ask the vacuum system to alternately vacuum convey *two* materials, and each time a material is to be loaded, it takes time to stimulate the material into motion by vacuum. This process adds valuable time to the conveying process and can create conveying problems if too many 'mixing' cycles are set on the control.

Also, the density and flow characteristics of virgin and regrind materials are typically very different, as well as the conveying distances. These factors must be taken into consideration as the percentage and number of valve cycles are set on the proportioning controls. A 50% setting of vacuum time dedicated to regrind will never equate to a 50% quantity of regrind material ending up in the receiver. It is best to make trial and error tests of proportional loads to see what results are created rather than assuming a specific outcome based purely on control settings.

It is common that vacuum on time for any receiver equipped with a proportional valve must be increased to allow for the dual loading capabilities of the proportioning valve.

13-MAINTENANCE

13.1 VR Series - FLAT SCREEN FILTER CLEANING:

VR Series receivers are typically used for conveying virgin pellets and/or regrind. The amount of regrind or small, irregularly sized particles within the conveyed materials that might be trapped in the screen, along with conveying velocity and throughput will all determine the frequency of necessary screen filter cleaning. Typically a standard screen filter will only need to be manually cleaned when changing materials. Or in the event of infrequent (or no) material changes, once a week.

CAUTION: Be sure to turn off the receiver at the central control and/or disconnect electrical power and compressed air supplies before any type of maintenance. Receivers may be automatically energized to operate with no warning, startling the maintenance worker.

The filter screen may be removed for inspection and cleaning by unclamping the ring clamp of the lid, directly below the vacuum connection. If necessary, disconnect the vacuum line. Carefully remove the lid and expose the flat disc filter directly below the lid. The screen may now be removed for inspection and cleaning.



Vacuum cleaning the bottom of the screen is recommended to remove collected resin debris, dust and fines. If compressed air is used, be sure to wear goggles and blow from the top (course, expanded metal side) of the filter down through the finer screen media. Never bang the filter against a hard surface to dis-lodge debris. Distortion of the media or sealing ring can result.

Once clean, thoroughly inspect the filter for severe wear, holes, tears and material abrasion. Any break in the filter media indicates the need for new filter. Do not attempt to repair the screen. Remember that the screen assures that loaded material makes it way into the process and not to the vacuum line, central dust collector or pump. In addition, examine the sealing ring around the screen filter. This ring provides the vacuum seal between the lid, the filter and the receiver body. The ring must be smooth, clean and intact to provide a suitable seal for vacuum sealing. Replace the filter if the seal is not in perfect shape.

Once cleaning/inspection is complete, the filter may be reinstalled by placing it on the flat rim of the loader body (fine screen DOWN and course screen UP) and placing the receiver lid down upon it and centering the screen filter between the two. Replace the clamp and tighten. With newly installed filters, the clamp may need to be adjusted to provide a vacuum-tight and mechanically firm seal.

13.2 CARTRIDGE FILTER CLEANING

VRP Series receivers are typically used for conveying free flowing powder materials. For this task, they are equipped with higher capacity cartridge filters. The amount of dust within the conveyed materials will determine the frequency of necessary manual filter cleaning.

NOTE: Although the blowback system of the receiver will extend the operational life of the filter media, it cannot be relied upon alone. Frequent checks of the filter accompanied by thorough manual cleanings are required, in addition to cleanings during material changes to prevent cross contamination.

CAUTION: Be sure to turn off the receiver at the central control and/or disconnect electrical power and compressed air supplies before any type of maintenance. Receivers may be automatically energized to operate with no warning, startling the maintenance worker.

The cartridge filters may be removed for inspection and cleaning by unclamping the ring clamp of the lid, directly below the vacuum connection. If necessary, disconnect the vacuum line. Carefully remove the lid and expose the cartridge filter mounting plate directly below the lid. The cartridge filter mounting plate, with the cartridge filters installed below it may now be carefully removed for inspection and cleaning.

If only light cleaning of the cartridge filters is required, the filters may remain installed onto the filter plate and cleaned in place. However, full removal and thorough cleaning of each cartridge is highly recommended. Vacuum clean the outside of the filters to remove collected resin debris, dust and fines. If compressed air is used, be sure to wear goggles and blow from the inside of each filter down through and out of the filter media. Never bang a filter against a hard surface to dis-lodge debris. Distortion of the media or sealing ring(s) can result.

Once clean, thoroughly inspect the filter for severe wear, holes, tears and material abrasion. Any break in the filter media indicates the need for new filter cartridge. Do not attempt to repair the media. Remember that these filters assure that loaded material makes it way into the process and not into the vacuum line, central dust collector or pump. In addition, examine the sealing ring around the top of each filter cartridge. This seal provides the vacuum seal between the cartridge filter and the filter mounting plate and must be fully intact. Replace the cartridge if this seal is not perfect.

If compressed air is used, blow down through inside of filter to the outside.

Vacuum Cleaning of filter(s) exterior is recommended

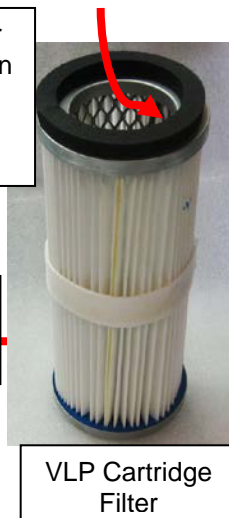

13.3 WASHING CARTRIDGE FILTERS

Polyester filter cartridges, supplied as standard with all NOVATEC VRP receivers are also washable to extend their life. Use one of the procedures outlined below. This cleaning procedure enables soiled filter cartridges to be put back into operation at lower pressure differentials. Cartridges may be washed several times to extend their operational life, but use caution to avoid letting high pressure water puncture filter media that may already be weakened by prolonged exposure to abrasive materials during vacuum loading:

POLYESTER FILTER CARTRIDGES WASHING, VARIANT A:

Wash with a commercial high-pressure cleaner, in compliance with the following conditions:

- Pressure: Temperature: max. 212°F (100°C)
- Cleaning agent: Maximum pH 5 - 7
- Cleaning Procedure: 8 to 10 pleats can be cleaned at a time, moving slowly from top to bottom, holding the nozzle approximately 12 in. (30cm) away from the filter. Water collecting inside the filter at the bottom can be drained out by tilting the cartridge.

POLYESTER FILTER CARTRIDGES WASHING, VARIANT B:

- Wash with a jet attachment from a conventional water hose.
- Cleaning procedure: Hold the hose at a distance of at least 2 inches (5 cm) from the surface of the cartridge, and use the jet to spray out each pleat from top to bottom.

13.4 DRYING THE CARTRIDGE:

The cartridge must be thoroughly dried in order to ensure trouble free operation after they have been cleaned. Choose:

- Dry at room temperature for a period of not less than 1 week.
- Dry in an oven at temperatures of max. 212°F (100°C) over a period of 12 hours.

Once each cartridge is cleaned, dried and inspected, it may be re-installed onto the filter mounting plate in the same fashion it was removed. Examine the filter mounting plate to be sure it is intact and its perimeter seal is smooth and clean since it will form a vacuum tight seal between the receiver lid, the filter mounting plate and the receiver body. Replace the seal if it is not in perfect shape.

Once filter cartridges are mounted to the filter mounting plate, reinstall it by placing it on the flat rim of the receiver body with the cartridges down inside the body. At this point, **it is critical that each cartridge filter is located directly below one of the receiver lid's blowback nozzles that will clean it during the blowback sequence.**

By viewing the receiver lid and the blowback nozzles on the underside of it, the filter plate may be rotated into proper position prior to placing the lid down on it and centering the filter plate between the two. Each blow down jet on the lid must be centered over a cartridge filter for effective blowback action. Replace the clamp and tighten. With newly installed filter plate seals, the clamp may need to be adjusted to provide a vacuum-tight and mechanically firm seal.



3 Cartridge Filters are Mounted on a Common Plate in all Models Except the VRP-5

14-TROUBLESHOOTING

14.1 PROBLEM: POOR OR NO CONVEYING:

1. VACUUM T VALVE OPERATION

Each vacuum receiver in the conveying system is coupled to a vacuum “T” valve that isolates the vacuum conveying power of the pump to one receiver at a time for conveying. Each T valve in the system must close off air flow when it is NOT in operation, allowing other receivers to receive full vacuum. One ‘stuck’ valve can ruin the vacuum supply for the entire system. Check that each valve operates in response to its receiver’s turn in the vacuum system. Each valve should open for loading and close when loading is complete. The extended shaft of the valve’s cylinder is a good indication of valve operation.

Rule of thumb: If only one receiver in the system is conveying correctly, it is probably that receiver’s T valve that is not closing properly.

2. RECEIVER DISCHARGE FLAPPER STUCK OPEN

The flapper valve at the base of the receiver provides three critical functions:

- Seal off the base of the receiver, creating a sealed vacuum chamber and allowing it to load,
- Open reliably to allow material to empty out and
- Signal the conveying control system of the need for more material (when it swings shut, by its own weight).

If the flapper valve is stuck open or does not fully close, conveying cannot take place. A problem receiver can be easily checked for proper, free movement of its flapper valve:

- If conveying is not triggered when the flapper is closed, there is an issue with the electrical demand switch.
- If the flapper does not swing nearly shut by its own weight, there is a pivot point (hinge) or counterweight issue.
- If the flapper is ‘stuck’ in the open position, there is a material contamination issue with the pivot point (hinge) of the valve and it must be cleaned and examined for wear. Contamination of the hinge is typically caused by material, finding its way into the pivot point, but in older receivers, may also be a metal burr that has formed from age.

3. INLET CHECK VALVE STUCK OPEN

Many receivers are equipped with swinging check valves on their material inlets. Check valves provide a variety of useful functions for system operation and are pushed open when material is conveyed into the receiver. But on systems that convey material from one source to multiple receivers, each check valve in the system must seal to allow the one receiver being loaded to receive the full vacuum force from the conveying pump. A check valve that is stuck open, either by hinge wear or a trapped pellet, will leak valuable vacuum air, decreasing vacuum capability at other receivers or even preventing conveying throughout the system.

Rule of thumb: On systems that convey material from one source to multiple receivers via a common material line; If only one receiver in the system conveys correctly, it is probably that receiver’s check valve that is not closing properly.

4. CONVEYING CONTROLS NOT PROPERLY (RE) PROGRAMMED

Central material conveying systems that include a network of pumps, receivers and material sources provide high efficiency and a multitude of flexibility. But often, new requirements are not completely programmed after material or system configuration changes. Items to check:

- Is the new material source further away than the previous source? More conveying time and/or purge time might be required to accommodate this difference in distance.
- Is the new material as free-flowing as the last material? Does the material have a tendency to clog the conveying lines, or simply convey slower due to weight or shape? Changes to load/purge times as well as material pick-up tube changes may be required.
- Has the receiver been assigned to the proper vacuum pump? The proper material valve?
- Has system piping and or wiring been modified to accommodate this new configuration for conveying?

5. CONFIRM PROPER VACUUM BREAKER VALVE OPERATION

Located on the central vacuum pump of the system, the vacuum breaker valve allows ambient air to be drawn into the pump when the conveying system is NOT conveying. This function prevents rapid re-starts and stops of the pump during the “seek” time of the loading control, cools the pump and prevents the over loads in the pump starter from over heating. But the pneumatically-operated breaker valve must close and seal when the vacuum system is conveying material, directing all vacuum force to the job of conveying. Check the following:

- The valve is connected to a reliable source of clean compressed air, which is turned on. Air pressure should be 85-120 psi.
- The valve must not be leaking vacuum air. Often a sucking sound can be heard, indicating the valve is not sealing properly.
- View the level of vacuum created by the pump on its vacuum gage while attempting to convey material: Although the reading on this gauge will vary greatly depending upon your system configuration, it is a valuable tool for assessing system operation and discovering faults. Vacuum levels below 6” indicate a breaker valve fault or other problems in the vacuum system.

6. CHECK THE SOURCE OF YOUR MATERIAL

Easily overlooked, the source of your material may be either empty or the wrong tubing or valve connections have been made.

Common bulk box issues are:

- Rat-holing: The feed tube has sucked up all the free-flowing material around its pick-up end and the material must now be stirred to allow material to flow into the feed tube again. A Gaylord tilter may be helpful in this situation.
- Bag liner line plugging: The feed tube has sucked in the thin film lining of the gaylord, blocking off material flow to the receiver.
- Feed tube fell out of the box: By weight of its own hose, or by vibration of the flex hose while conveying.
- Out of material: Time to move in a new bulk box.

Common material selection issues:

- Conveying line connected to the wrong source of material:
- Wrong purge valve selected: If a purge valve is used at the material source, it must be programmed by the system control to operate in conjunction with a specific receiver. Material changes require making a new valve selection at the system control.
- Purge valve is not operating: If a purge valve is used at the material source, it must be energized to allow material loading (and de-energized for purging). A fault at this valve, IE: lost compressed air connection, an open purge valve access door or a material jammed purge valve will prevent material movement.

7. FEED TUBE / TAKE-AWAY BOX AIR SETTINGS

The conveying of material by air cannot be accomplished without air movement. Regardless of the type of pickup device being used; purge valve, wand, take-off box, etc.... these devices must be adjusted to allow the introduction of material and air, in a mixture suitable for conveying the specific material the distance required.

15-WARRANTY - Effective Date 7 February 2018

NOVATEC, INC. offers COMPREHENSIVE PRODUCT WARRANTIES on all of our plastics auxiliary equipment. We warrant each NOVATEC manufactured product to be free from defects in materials and workmanship, under normal use and service for the periods listed under "Warranty Periods". The obligation of Novatec, under this warranty, is limited to repairing or furnishing, without charge, a similar part to replace any part which fails under normal use due to a material or workmanship defect, within its respective warranty period. It is the purchaser's responsibility to provide Novatec with immediate written notice of any such suspected defect. Warranted replacement parts are billed and shipped freight pre-paid. The purchaser must return the suspect defective part, freight prepaid and with identifying documentation to receive full credit for the part returned. Novatec shall not be held liable for damages or delay caused by defects. No allowance will be made for repairs or alterations without the written consent or approval of Novatec.

The provisions in equipment specifications are descriptive, unless expressly stated as warranties. The liability of Novatec to the purchaser, except as to title, arising out of the supplying of the said equipment, or its use, whether based upon warranty, contract or negligence, shall not in any case exceed the cost of correcting defects in the equipment as herein provided. All such liability shall terminate upon the expiration of said warranty periods. Novatec shall not in any event be held liable for any special, indirect or consequential damages. Commodities not manufactured by Novatec are warranted and guaranteed to Novatec by the original manufacturer and then only to the extent that Novatec is able to enforce such warranty or guaranty. Novatec, Inc. has not authorized anyone to make any warranty or representation other than the warranty contained here. Non-payment of invoice beyond 90 days will invalidate the warranty. A renewed warranty can be purchased directly from Novatec.

Please note that we always strive to satisfy our customers in whatever manner is deemed most expedient to overcome any issues in connection with our equipment.

Warranty Periods:

Note: All warranty periods commence with the shipment of the equipment to the customer.

5-Year (Except 1-Year on Non-Novatec Buy-Out Items)

Resin Drying to Include

NovaWheel™ Dryers *
Dual Bed Dryers
NovaDrier *
NDM-5 Membrane Dryer
Gas-Fired Process Heaters
Gas-Fired Regeneration Heaters
Drying Hoppers
Central Drying Hopper Assemblies
Heater/Blower Units and Hot-Air Dryer
Silo Dehumidifiers
NovaVac Dryers *
Nitrogen NovaDriers (Nitro)
DryTemp Plus

Central System Controls to Include

FlexTouch™ Series Controls
FlexXpand™ Series Controls
OptiFlex™ Series Controls
PLC Communications Modules
Greenboard Communications Modules
LOGO! Mini PLC
MCS-600 Series Controls – (Distributed I/O)
MCS-400 Series Controls
CL Silo Manager

Moisture Measurement Equipment to Include

MoistureMaster®

PET Resin Crystallizers

Resin Blending and Feeding to Include

WSB Blenders, MaxiBatch & Feeders *
Gaylord Sweeper Systems

Downstream Extrusion Equipment to Include

C and NC Bessemer Series Cutters
NPS Bessemer Series Pullers
NPC Mini Puller/Cutter
All NS Series Servo Saws
All Cooling and Vacuum Tanks Manufactured by Novatec

Resin Conveying and Systems Components to Include

GSL Series Vacuum Loaders
GlassVu Loaders, Receivers and Hoppers
VL/VLP Series Loaders
VRH, VR, VR-FL & VRP Series Receivers
Compressed Air Loaders
AL-B Barrel Loader
Cyclone Dust Collectors
Conveying System Accessories
Surge Bins
Valves and Accessories
Electronic Metal Separators
Quick Select Manifolds
Tilt Tables
Filter Dust Collectors
Drawer Magnets
Velocity Control Valves

3-Year

Resin Conveying System Components to Include

** VPDB Vacuum Positive Displacement Pumps
** SVP Vacuum Pumps
** MVP Vacuum Pumps
** Railcar Unloading Systems

****5-Year Extended Warranty** - When a MachineSense® data plan is activated for products with **, Novatec automatically extends the warranty to 5 years. The data plan must be activated within 60 days after product shipment, and remain active through the warranty period to maintain extended warranty eligibility. The first 6-months of data plan usage is free from Novatec.

1-Year

Infrared Dryers
UltraVac Vacuum Pumps

Vacuum Regenerative Blower Pumps
Custom Equipment of any kind unless otherwise specified

Exclusions:

Routine maintenance/replacement parts are excluded from the warranty. These include, but are not limited to: hoses, desiccant, filters, filter elements, wiper seals, gaskets, dew point sensors, infrared lamps, motors, internal solenoids, fuses and motor brushes. Use with abrasive materials will void the warranty of any standard product. Wear resistant options may be available to extend usable service life with abrasive materials. Novatec reserves the right to limit the warranty if the customer installs replacement parts that do not meet the specifications of the original parts supplied by Novatec.

***Specific Exclusions:**

1. NovaDrier and NovaDrier-Nitro warranty is void if coalescing filters are not replaced on a 6-month or yearly basis (per instruction manual) and/or membrane has been exposed to ozone.
2. NovaVac Dryer -The ability of the canisters to hold vacuum will be compromised if the vacuum seal edge is damaged from mishandling. We do not warranty canisters damaged from improper handling. We do, however, warranty the seals.
3. LOAD CELLS on our WSB's are covered by Novatec standard warranty as long as they have not been damaged from improper handling.
4. Desiccant Wheel Warranty will be void if the wheel has been exposed to plasticizer, dust or other contaminants as a result of negligence on the part of the processor.

This warranty shall not apply to equipment:

1. Repaired or altered without written approval of NOVATEC unless such repair or alteration was, in our judgment, not responsible for the failure
2. Which has been subject to misuse, negligence, accident or incorrect wiring by others
3. Warranty is void if processing rates exceed manufacturer-recommended levels or if damage is caused by ineffective power isolation and/or power spikes/sags or incorrect installation.

NOTE: All conditions and content of this warranty are subject to changes without notice.