



VRB Vacuum Pumps

These compact, quiet, low maintenance pumps provide powerful vacuum to convey free flowing pellets, powders and regrind.

Each VRB is shipped fully assembled, and lubricated to deliver optimum vacuum.

New! Temperature Switch – Standard. Extends the life of the blower by monitoring blower temperature. When limit is exceeded, the temperature switch activates vacuum breaker cycle to cool the blower, indicated by red LED on the control box.



New!
Temperature safety switch

Lower Noise Level

Operates more quietly than positive displacement pumps.

End Mounted Bearings

Reduces load and improves cooling.

Electronic Motor

Overload Protection

Phase loss detection, plus quicker trip speed vs. thermal overload provides superior motor protection.

New! Temperature Switch - Standard

Extend the life of the blower by monitoring blower temperature. When limit is exceeded, the temperature switch activates vacuum breaker cycle to cool the blower, indicated by red LED on the control box.

Vacuum Breaker Valve and Safety Filter

Provides trouble free operation and long pump life by minimizing pump starts and internal dust contamination.

Plus

- › Housing - aluminum
- › Impeller – aluminum, dynamically balanced
- › Direct drive impeller
- › Inlet/outlet silencers included
- › High temperature internal shaft seal and bearings
- › Class H motor insulation with 1.15 service factor
- › Performance tested ANSI/AMCA210-85
- › Voltage: 460/3/60 standard or choose optional 575/3/60 or 400/3/50
- › 1-year warranty

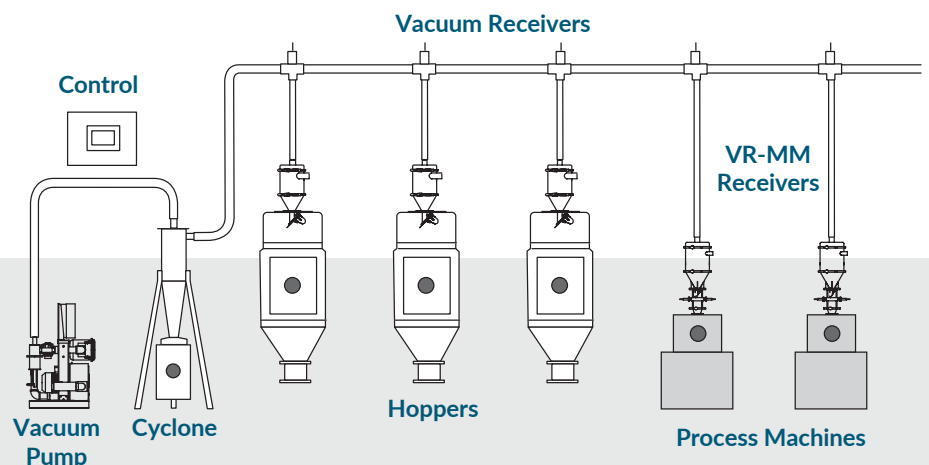

Specifications: (Consult factory for elevations above 3000 feet.)

Model	Stages	Pump Power	Line Size O.D.	Operating CFM	Operating/Relief Vacuum		Width	Depth	Height	Shipping Weight
		Hp	in	60Hz/50Hz	60Hz,Hg(in)	50Hz,Hg(in)	in	in	in	lb
VRB-3S	Single	3.5	1.5	55/55	6.5/7.5	4.5/6	24	26	40.5	140
VRB-5D	Dual	5.0	1.5	70/60	10/11	7/8.5	24	26.5	40.5	200
VRB-5S	Single	5.0	2.0	110/80	6.5/7.5	5.5/6	24	27.5	40.5	180
VRB-8D	Dual	8.5	2.0	125/115	11/12	8.5/10	28	35.5	46.5	250
VRB-11S	Single	11.5	2.5	200/140	9.5/10	7.5/8.5	28	34.5	46.5	400
VRB-17D	Dual	17.5	2.5	200	11/12	9.5/12	28	37	46.5	580

Standard Control Voltage: 24 VDC Standard motor voltage 460/3/60

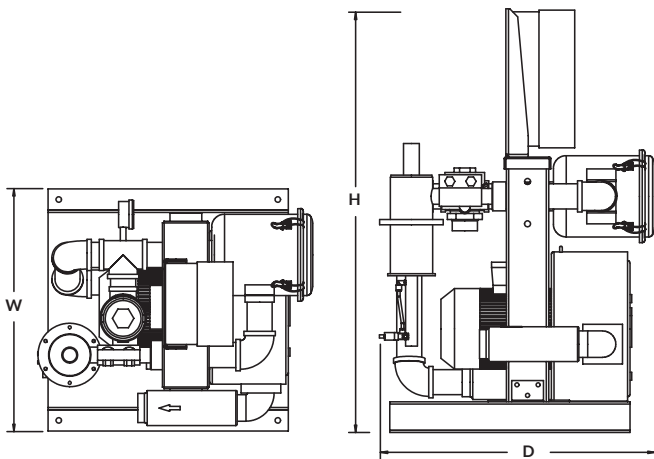

Basic package includes:

Pump with starter plus disconnect (Power isolation switch, contactor, electronic motor overload circuit breaker).

Options:

Alternate Control Voltages: 115/1/60 VAC (No charge)

Alternate Power Voltages: 460/3/60 (standard)

575/3/60 (no charge) includes fused disconnect with thermal motor overload protection 400/3/50 (No charge)

DeviceNet Cable(s) for Pump: In lieu of standard cable(s) (Available in 24 VDC only)

Accessories:

DeviceNet Cable: (in lieu of standard cables -24VDC only)

DSV Discharge Selection Valve for Dry Air Conveying:

EPV valve with connection stub to pump for 115 VAC or 24 VDC for line diameters of 1.5", 2" and 2.5".

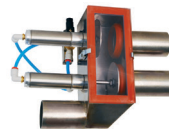

DSV Discharge Selection Valve

CLR Closed Loop Valve with Relief Vent: Provides pressure relief in a closed loop conveying system for line diameters of 1.5", 2", 2.5" and 3".



CLR Closed Loop Valve with Relief Vent