

Extrusion Up cut Traveling Saw Model NS-6



© NOVATEC, INC 2021 All Rights Reserved

Instruction Manual NS-6 IM 25 JAN 2021



Novatec, Inc. 222 E. Thomas Ave. Baltimore, MD 21225 | www.novatec.com

Phone: 410-789-4811
Toll Free: 800-938-6682
Main Fax: 410-789-4638

Parts Email: parts@novatec.com
Service Email: service@novatec.com
Sales Email: sales@novatec.com

Please record the following information, which is specific to this piece of equipment, in the space provided. Our Parts / Service department will need these numbers to properly respond to any of your requests

Instruction Manual: NS-6 IM 25 JAN 2021

Model#: NS-6

Serial # _____

Software Version _____

DISCLAIMER: NOVATEC, Inc. shall not be liable for errors contained in this Instruction Manual nor for misinterpretation of information contained herein. NOVATEC shall not, in any event, be held liable for any special, indirect or consequential damages in connection with performance or use of this information.

Table of Contents

1.0 PURPOSE OF THIS MANUAL.....	5
Explanation of Symbols.....	5
2.0 SAFETY PRECAUTIONS AND WARNINGS.....	5
3.0 GENERAL DESCRIPTION.....	6
3.1 Features.....	6
3.2 Specifications Model # NS-6.....	6
4.0 SPECIFICATIONS.....	7
5.0 INSTALLATION.....	8
5.1 Unpacking.....	8
5.2 Mechanical Installation.....	8
5.2.1 Positioning the Saw.....	8
5.2.2 Final Alignment and Leveling.....	9
5.2.3 Air.....	9
5.2.4 Dust Collector.....	9
5.3 Mechanical Operation and Adjustments.....	10
5.4 Saw Clamp Instructions.....	11
5.4.1 Ensure Product Fits.....	12
5.4.2 Blade Shroud Cover - Choose Clamp Plate Orientation.....	13
5.4.3 Clamp Product.....	13
5.5 Mechanical Checks & Pre-operation Inspection.....	14
6.0 ELECTRICAL INSTALLATION.....	15
7.0 STATUS LIGHT.....	16
7.1 Safety Information.....	16
8.0 SCREEN CONVENTIONS AND COMMON ELEMENTS.....	17
8.1 Button Borders.....	17
8.2 Logon, Password levels & alphanumeric keypad for entering username / password.....	17
8.3 Screen Title.....	18
8.4 Machine Status.....	18
8.5 Standard Navigation Buttons.....	18
8.6 Numeric Keypad.....	18
8.7 HOME Screen.....	19

9.0 POWER UP SEQUENCE 20

10.0 QUICK OPS EXAMPLE SCREENS 21

10.1 Quick Ops Buttons 22

 10.1.1 Cut Parameter 22

 10.1.2 Blade Controls 22

 10.1.3 Measured Length 22

 10.1.4 Control Buttons..... 22

 10.1.5 Recipe Functions..... 23

 10.1.6 Count Setup..... 23

 10.1.7 Counters 24

 10.1.8 Batch Counter Setup 24

 10.1.9 Production 24

11.0 RECIPE SCREENS 25

11.1 Recipe Screen..... 25

11.2 Recipe Select Screen..... 26

12.0 COUNTERS 26

13.0 SETUP SCREENS..... 27

13.1 SETUP 1 28

13.2 SETUP 2 29

13.3 SETUP 3 30

13.4 Servo Setup Page 32

14.0 MAINTENANCE..... 33

Installation 33

At Startup 33

Daily 33

Weekly..... 33

Every 3 Months 33

15.0 WARRANTY 34

1.0 PURPOSE OF THIS MANUAL

This manual describes the installation and operation of the NOVATEC, NS-6 Saw. Before installation of this product, please read this guide and any additional guides associated with the system's auxiliary equipment.

Explanation of Symbols

This manual includes both general and task-specific safety precautions. These precautions are highlighted in the manual by the following categories:



WARNING: This symbol identifies situations that are potentially hazardous to personnel or equipment.

NOTE

Highlights information provided in text or procedures. This information may or may not be related to safety.

2.0 SAFETY PRECAUTIONS AND WARNINGS

These operating instructions must be read, understood, and implemented by all personnel responsible for this system.

- ❑ All mechanical and electrical work **MUST** be performed by qualified personnel.
- ❑ **NEVER** disable or remove safety features. Doing so can result in severe injury.
- ❑ Always disconnect power and lockout power before servicing.
- ❑ Always disconnect pneumatic sources before servicing.
- ❑ Refer to the machine serial number, nameplate and drawings supplied with this system for correct power requirements.
- ❑ Be sure to install the equipment with the proper electrical connections according to all national and local regulations.
- ❑ Electric power supply should be through a separate disconnect switch with properly sized overload, circuit breaker or fuse protection.
- ❑ The customer is required to operate the equipment with all safety features in place and in proper working condition.
- ❑ NOVATEC shall provide no further guarantee for function and safety in the event of unauthorized modifications.

3.0 GENERAL DESCRIPTION

The NOVATEC, NS-6 Saw offers high versatility to cut a wide range of profiles. The extrusions are fed through the saw from an upstream puller. When a pre-determined length of extrusion has been fed, a cut cycle is activated to cut the extrusion to length. It does this in synchronization with the line speed.

3.1 Features

- Servo driven table travel
- Heavy-duty welded steel framing
- Swivel casters for increased mobility
- 120 tooth 20" carbide blade with triple chip grind *
- Access to saw compartment through access panels on 3 sides
- Front panel-mounted pneumatic controls
- Hinged table for easy blade change access
- User friendly touch-panel operation
- 5-Year Warranty

3.2 Specifications Model # NS-6

- 42" centerline height with +/- 2" of adjustment
- 24" of Servo Table Travel
- 20" diameter blade
- R-L extrusion flow
- 460VAC / 3-phase / 60Hz

* This type of blade affords the best cut finish for Rigid PVC. Toothed blades can be used but create noise. Noise is reduced by chip collection vacuum and adjustment of blade speed.

Machine Videos

Please follow this link for demonstration videos: <https://www.youtube.com/user/novatecinc/videos>.

4.0 SPECIFICATIONS

Model Number	NS-6
Blade Diameter	20"
Cut Capacity	6"
Saw Arbor Motor	3 HP
Cuts per Minute	15 cpm max *see note
Variable Motor Speed	1,000 to 3,500 rpm
Table Travel	24"
Table Travel Speed	45 fpm
Electrical	460VAC 3PH 6.7FLA

NOTE: Exceeding 15 cpm may void the warranty

Dimensions: NS-6 Extrusion Saw

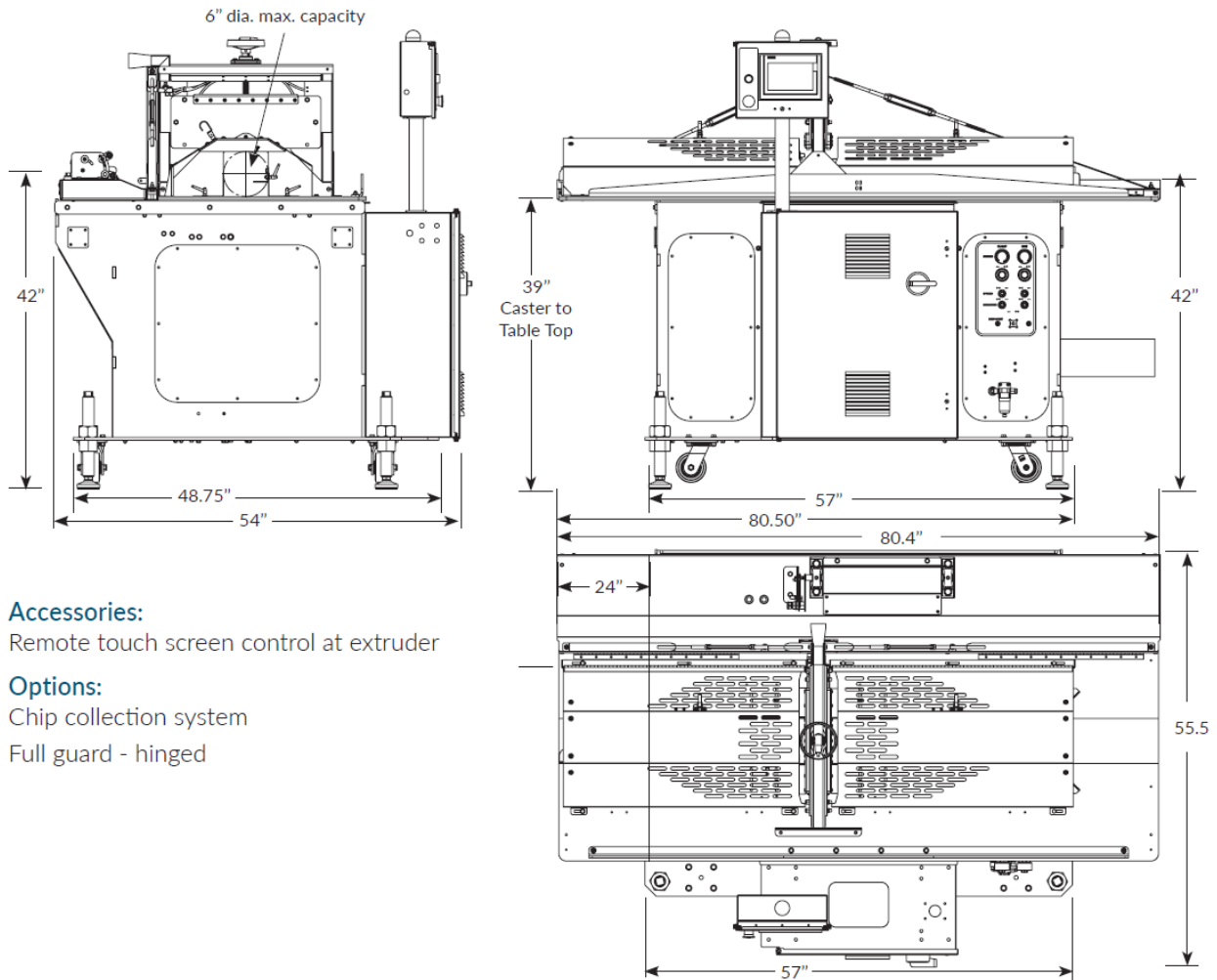

Accessories:

Remote touch screen control at extruder

Options:

Chip collection system

Full guard - hinged

5.0 INSTALLATION

5.1 Unpacking

1. Carefully unpack the saw and any other components delivered with it. Check all packaging for loose parts, documentation, and other included items. Carefully inspect all parts. Ensure that no wires, bolts, screws, terminals, or other connections have come loose during shipping. Check to ensure that all moving parts are not obstructed by debris or excess packing material. Store documentation where it can easily be retrieved.
2. You may require the following tools to complete the installation:
 - a. Adjustable wrench
 - b. Phillips and flat blade screwdriver
 - c. Hex Wrenches
3. Remove Shipping Brackets from underside of both ends of the table and retain them for linear bearing servicing procedure.

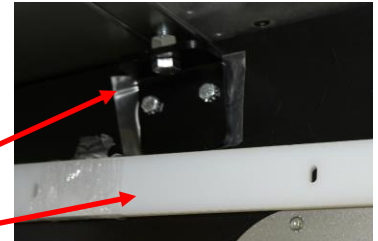

CAUTION: Attach the supplied polyethylene strips in place of the Shipping Brackets at the underside of table ends. These are important to **eliminate pinch points** between the table and the saw frame.

3. Manually push table from end to end to ensure it is free to travel.
4. All national and local electrical, building, and safety codes need to be followed. Proper grounding of all equipment is important. Check the electrical wiring schematic for wiring numbers and details. The following paragraphs describe installation of typical system components. Some of them are optional and may not be required for your system.

CAUTION: All machines must be grounded for electrical safety and to prevent static electricity shocks that are generated by some materials as they move.

All electronics are susceptible to electrostatic damage. Your CS-6 has been designed with electrostatic protection in mind. However, this cannot completely eliminate upsets due to excessive electrostatic voltage induced by the extrusion process. Grounding and use of static eliminators are very important.

5.2 Mechanical Installation

5.2.1 Positioning the Saw

Determine the required position of the saw. This should be done with consideration to the expected final location and adjacent equipment and the nature of the extrudate. Move saw to this position initially using the castors, align machine with process direction, then lower the stabilizing feet to hold the saw in place.

5.2.2 Final Alignment and Leveling

Once the general position has been determined, carefully align the saw with the extrusion line. It is easiest to adjust this position when on the floor before adjusting the height. Ensure that all equipment is properly aligned (pullers, tanks, etc.). To adjust the centerline height of the saw, adjust the stabilizing feet positioned at each corners of the frame. Once at the desired height, ensure that the saw table is level.

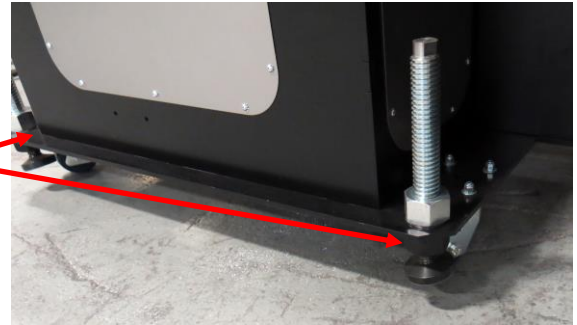

5.2.3 Air

Air from the plant main supply should be hooked up to the port at the lower front right side of the frame. This connection is 1/4" NPT female. Turn on air once it is safely connected. Ensure that there are no leaks.

5.2.4 Dust Collector

Install the dust collector 5" diameter tube to the tube on the upstream side of the saw and the 1-1/2" diameter tube on blade shroud (**Chip collection MUST be used**)

Attach 5" ID hose from your dust collection unit to the lower dust collection outlet.



NOTE: Inspect dust collector bag(s) regularly. Ensure smooth flow of particulate evacuation. Avoid binding of the telescopic ducting in the base of the saw and to the collector.



Tabletop dust / chip evacuation tube should be connected to the collection hose or plugged to avoid blowing dust / chips upward.

5.2 Mechanical Installation

5.2.1 Positioning the Saw

Determine the required position of the saw. This should be done with consideration to the expected final location and adjacent equipment and the nature of the extrudate. Move saw to this position initially using the castors, align machine with process direction, then lower the stabilizing feet to hold the saw in place.

5.3 Mechanical Operation and Adjustments

The CLAMP and SAW have been adjusted and tested at the factory prior to shipment. These settings are held in place with locknuts. Further adjustments should be made only if necessary and with the understanding of what each does. Loosen all locknuts before adjusting and retighten when done.

Set pressure on the clamp and saw regulators to 55 to 60 psi. These set the clamp force and the pushing force of the blade into the profile.

Cycle the machine valves from the Pneumatic Controls section of the SETUP 2 screen, as shown on page 29 of this manual.

Adjust clamp UP SPEED and DOWN SPEED by turning flow regulators. A separate speed control on the rear clamp cylinder is available to balance the front and rear cylinders. Set with a small blade screwdriver after removing the protective cover.

Adjust the saw "UP SPEED" until it is sufficient for cut quality and cycle rate. A separate speed valve on the rod end of the saw cylinder is available for a coarser speed adjustment.

Simultaneously adjust the saw "DOWN SPEED" and "DROP ADJUST" dials to get the blade to drop as fast as possible. This does not impact the stop point at end of forward travel. The drop adjust uses a variable volume pneumatic reservoir to provide air spring cushioning for blade down.



The easiest way to set the drop adjust is to rotate it fully counterclockwise (minimum volume) and then gradually increase this setting and the down speed setting until the saw arm drops without oscillation.

Use thumbscrew at rear of machine to position saw up height limit.

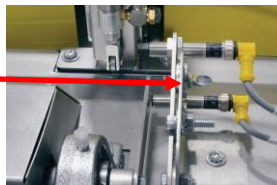



Turn on the Chip Collector.

On QUICK OPS screen, initially set a slow blade.

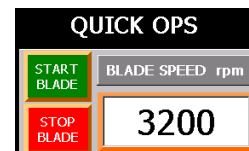
DO NOT EXCEED RECOMMENDED SAW BLADE SPEED



Set line speed on CURRENT RECIPE screen if in manual mode - saw will **not** operate without a speed reference. Access CURRENT RECIPE by pressing the  Edit Recipe button on the

Quick Ops screen. Perform a few test cuts and set blade height and speed by pressing  button on HOME PAGE and then accessing SETUP 2.

5.4 Saw Clamp Instructions

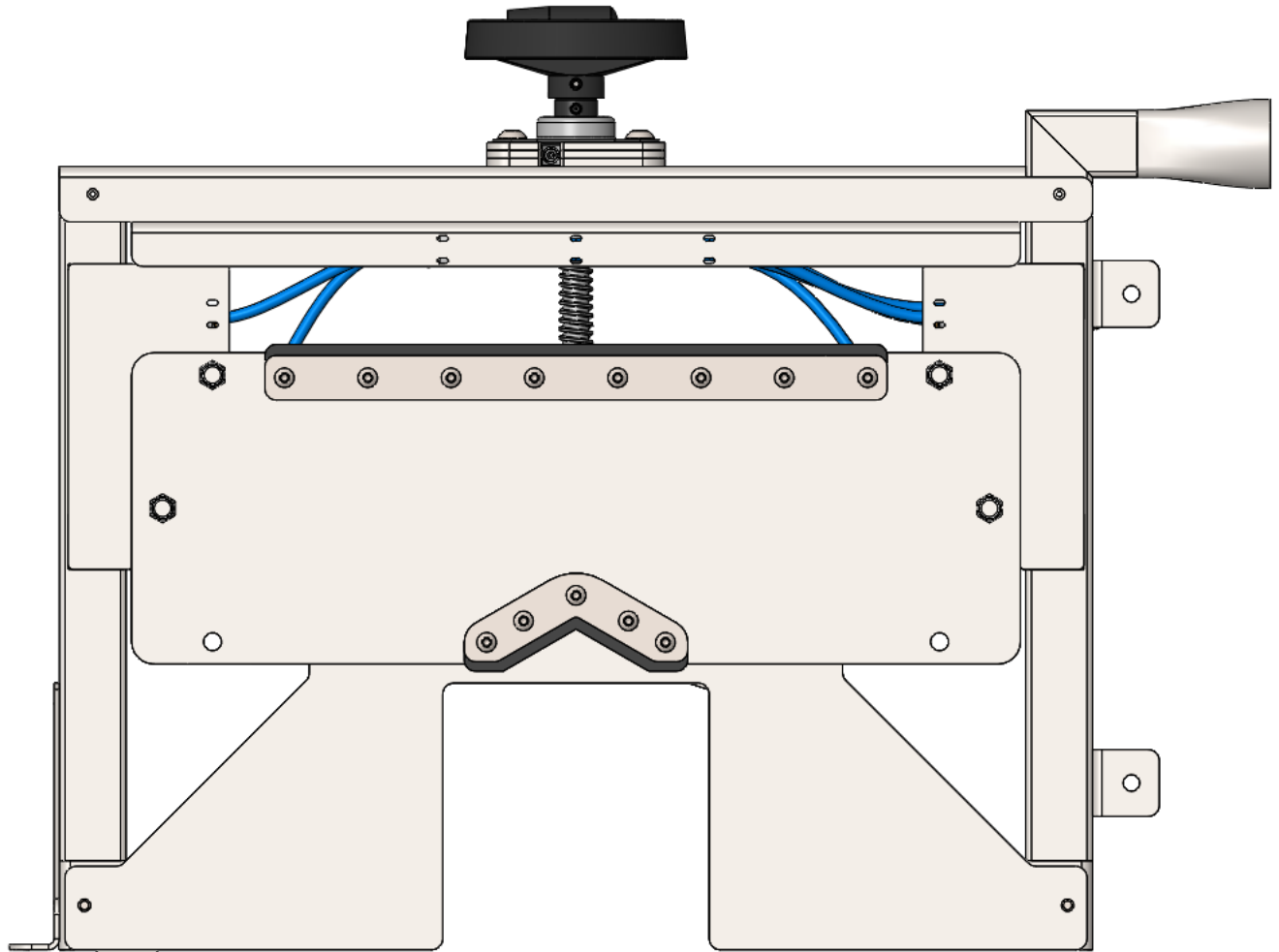

Blade Shroud Cover

This shroud aids with chip collection – it can be modified or swapped for other shapes to suit different profiles

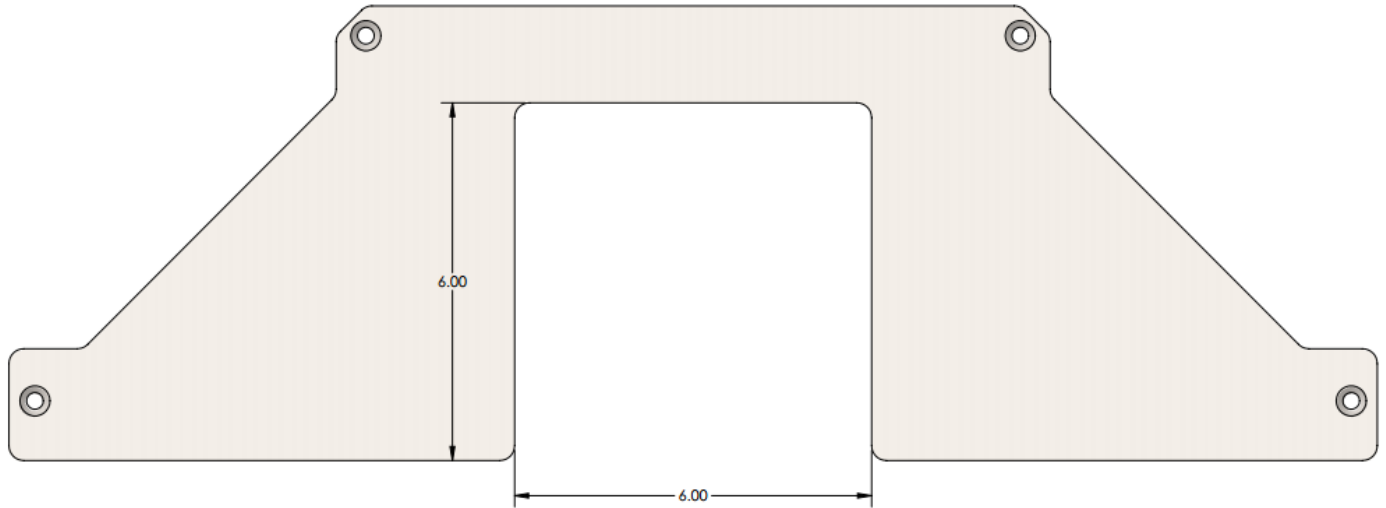

5.4.2 Choose Clamp Plate Orientation

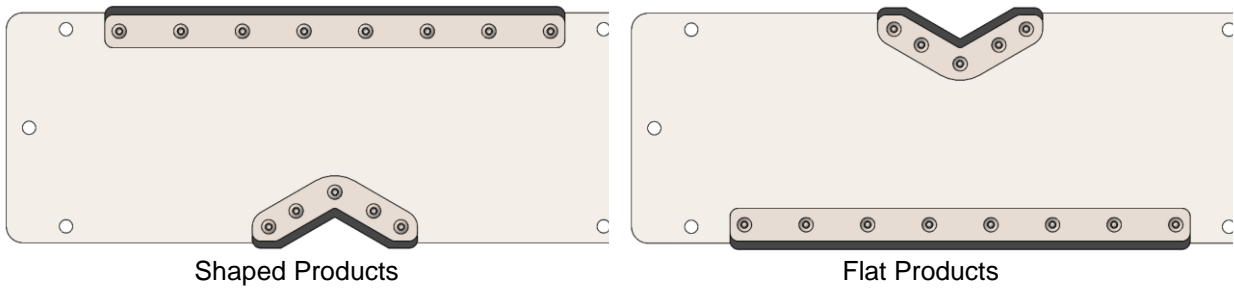

5.4.3 Clamp Product

Use handle to move clamp to desired height.

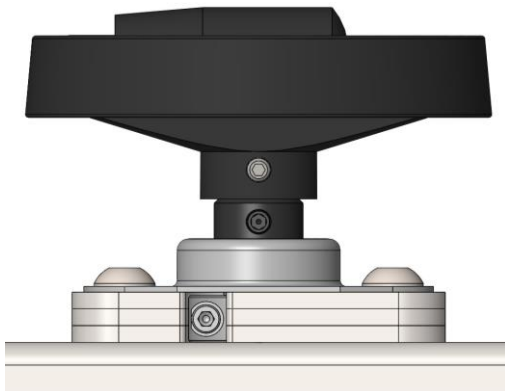

Once set, tighten shaft clamp to prevent unintentional changes.

Air cylinders add 1/2" of clamping

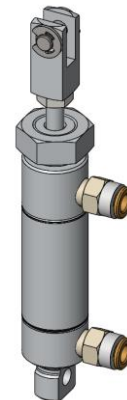

5.5 Mechanical Checks & Pre-Operation Inspection

- Open the hinged table – requires removal of 4 x 1/4" hex-head bolts at the front edge of the table, the upper blade shroud, clamp plates, dust shields and yellow guards. (See photos)

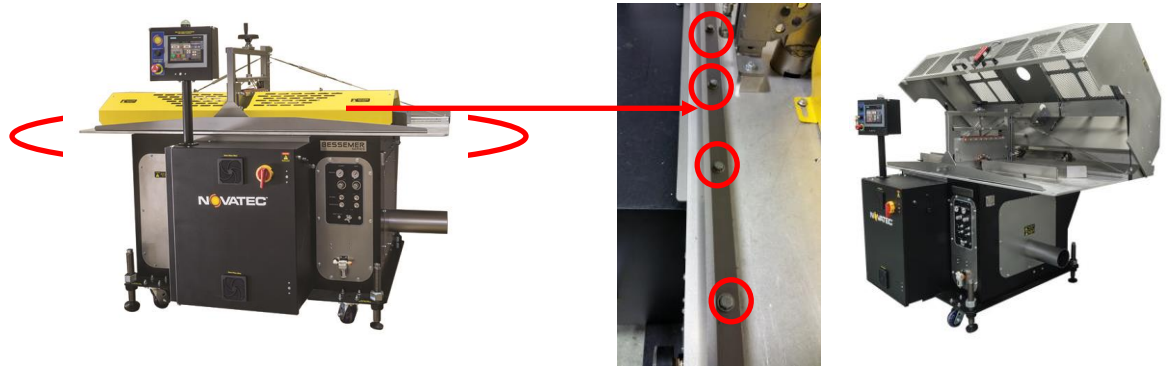

- Inspect chamber for proper blade assembly, blade run-out and free motion of arbor cover. (See photo) **NOTE: Arbor shaft has left-hand thread on NS-6 Saw.**
- Inspect blade marking for maximum operating speed.
- Close hinged table and secure with 4 x 1/4" hex head bolts.
- Reinstall the upper blade shroud.
- Reinstall clamp plates and aluminum dust shields.
- Re-install yellow tabletop guards.
- If using encoder mode install an encoder.

If not using an encoder, "LENGTH REF SOURCE" and "SPEED REF SOURCE" must be estimated and set at the CURRENT RECIPE screen.

- Options - Install cut signal trigger source. (24VDC sourcing) or obtain analog input kit from NOVATEC.

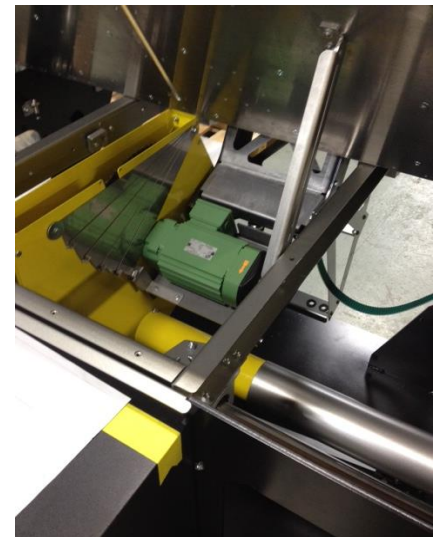

Sealed blade shroud for maximum chip collection



- **CAUTION: Never use equipment without the properly installed guarding which is appropriate to its location of use and compliant with local law and compliance guidelines.**

6.0 ELECTRICAL INSTALLATION

Always disconnect and lock out the main power supply before wiring power and control cables between the NS-6 saw and external devices. Refer to the wiring diagram and general arrangement drawings supplied with this system before making electrical connections.

- ❑ Use twisted-pair shielded cable for communications wiring, such as for RS-485 or Ethernet.
- ❑ Keep communication cables and control wiring as far as possible from high voltage equipment. If cables must run across power lines, keep them at right angles to the line.
- ❑ Ensure equipment grounding is properly connected. Shielded cable should be grounded at one end only in the main I/O enclosure to avoid ground loops.



WARNING: Avoid installing communication cable where it can be affected by static electricity!

Open the electrical enclosure and insert the main power through a knockout in the wall of the enclosure. Connect the power cable as indicated on the wiring diagram that was included with the machine. Check that all terminal screws are tight and secure. Close electrical enclosure.

Before powering up the machine, confirm that the placement and wires to the machine conforms to all applicable national and local regulations. When ready, turn on the power drop to the machine, then turn on the main disconnect at the electrical enclosure of the machine. Make sure that E-Stop button(s) are in the OUT position. Press the safety reset button after the machine has booted up.



CAUTION: All machines must be grounded for electrical safety and to prevent static electricity shocks that are generated by some materials as they move

All electronics are susceptible to electrostatic damage and, although as much protection as possible has been designed into the system; this cannot completely eliminate upsets due to electrostatic voltage being accidentally introduced into the electronic circuitry.



CAUTION: Ensure the blade is rotating in the correct direction.

7.0 STATUS LIGHT

The status light on top of the operator panel is used for machine alarm and status conditions. Below is the meaning behind this light.

- **Red – Fault.** A fault or safety condition that has stopped the machine.
- **Orange – Warning.** There is a condition that requires operator attention. The machine will continue to operate.
- **Flashing Orange – Table is Homing.** The table is moving home (at start up).
- **Off - Waiting for Start.** The system has homed but the blade must be started before the saw can be operated.
- **Flashing Green – Ready.** The saw is ready but not running. Press Run Product or Run Scrap to begin.
- **Green – Saw is Running Production.** The system is cutting production parts at the preset length.
- **Flashing Green and Orange –Scrap.** The saw is cutting Scrap parts.



Note: A piezoelectric horn is available. It can be configured to activate on warnings, faults or at a preset count. See the machine setup section for information on how to set this.

7.1 Safety Information



CAUTION: The blade should only be accessed after the machine has been powered down and locked out with proper lockout / tag procedures.



CAUTION: Ensure the blade has completely stopped. It may coast for many minutes.

NOTE: The Emergency stop will immediately stop table motion and the blade power will turn off. However, the blade will continue to run while it coasts to a stop.

NOTE: Quicker method: While the machine is safe, Use "Stop Blade" on the Quick Ops screen. This will stop the blade in about 45 seconds under control of the drive. After this period, the saw can be safely powered down and locked out.

Please contact NOVATEC if there are any questions or concerns.

8.0 SCREEN CONVENTIONS AND COMMON ELEMENTS

8.1 Button Borders

Buttons with a function have a raised border. When grey, there is no function. Pressing a button with a grey border causes a popup screen to appear with the prompt to enter a username, followed by password.



Pressed buttons change their border shadow to indicate to the operator that the press was recognized. A greyed button or field indicates that there is no function associated at the current access level. A higher-access level might allow access. Information prompts are also on a grey background.

8.2 Logon, Password levels & alphanumeric keypad for entering username / password

These procedures are common to all NOVATEC Pullers and Cutters.

Press  in upper right-hand corner of the screen.

An alphanumeric keyboard appears ...

NOTE: If the user access is not at a sufficient level, the operator will be prompted to enter a higher access level. A username and password must then be entered before any changes can be made.

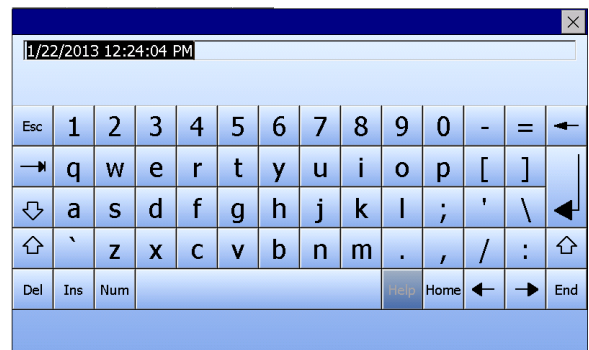

Default Usernames and Password:
 level1: 1111 (Operator)
 level2: 2222 (Production Supervisor)
 level3: 3333 (Maintenance)
 setup: 4444 (Setup for factory presets)

STOPPED			 level2
User	Password	Group	Logoff time
admin	*****	Administr...	15
level1	*****	Users	0
level2	*****	Production	5
level3	*****	Maintena...	15
novatec	*****	Novatec	15
pass	*****	Pass Virtual	5

Navigation icons: Home, QUICK OPS, Warning

NOTE: Access levels should be assigned to specific levels of personnel to avoid unwanted changes being made to sensitive settings.

 is used to log out and secure the system.

8.3 Screen Title

A Title is shown in the top center of every screen.

Example:



8.4 Machine Status

Machine Status is shown in the top right-hand corner of every screen.



8.5 Standard Navigation Buttons

Four buttons appear at the bottom of every screen. These provide quick navigation to other screens.



To
previous
screen

To
Home
Screen

To
QUICK
OPS
screen

To
Alarms
screen

8.6 Numeric Keypad (template)

Numeric parameters can be changed by the operator. Use Enter to accept the value that is typed in, otherwise to leave the previous setting use Esc to escape

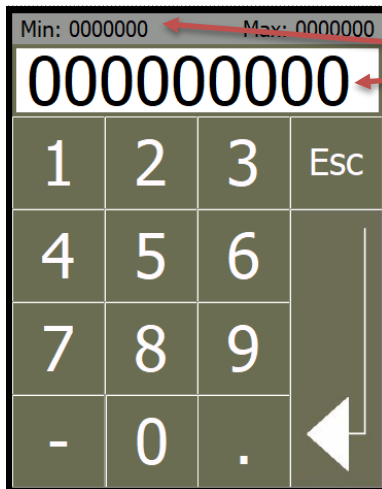

Maximum
Minimum
Current Value shows here when keypad first appears and is seen changing when a new value is typed in. Value entered cannot exceed limits.

8.7 HOME Screen



Quick Ops - opens the quick ops screen.



Recipe Select - opens the recipe select screen.



System Setup - opens the system setup screen (requires Level 3).



Batch Counters - opens the batch counter screen.



Center text / image shows model number and image for this saw. If the picture remains blank, there is likely a problem with communications.



Software Version – quote your revision number when contacting NOVATEC service.

9.0 POWER UP SEQUENCE

When powering up, a series of boot up operations take place to ensure that the safety system is functioning properly.



Splash Screen – is shown during boot up.

The screen is initially blue with a few icons and then the splash screen appears for about 3 seconds. If the splash screen remains on for too long maintenance should check for a problem.



Reset System to Home - This prompt in the top-left corner instructs the operator to Reset the System to home the saw table.

Follow along with on screen instructions – if safe to move the saw will begin HOMING (searches for home sensor).

The status light on top of the machine blinks orange. When home has completed, the screen will change to the Quick Ops screen and the light will turn off.



10.0 QUICK OPS EXAMPLE SCREENS

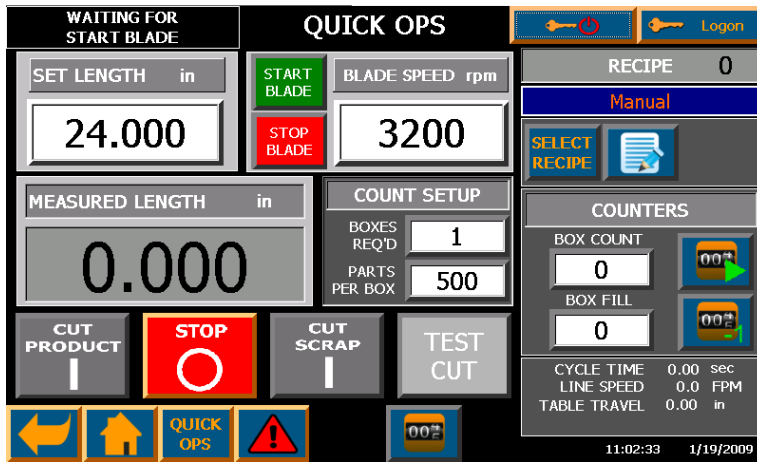

This is the default screen on startup after the splash screen. Quick Ops can also be accessed by using the Quick Ops button on the bottom of any screen.

It provides a quick overview and provides buttons and information relevant to the current mode.

Example: the screen before an operator has logged in. Its appearance is based on operating conditions and user setup options.



Example: level1 user. The grey borders around the buttons are now orange to indicate that the user has the proper authority to access them.

NOTE: Cut buttons are grey because the saw has not been homed or started.



Example: level 1 user after saw has been started.

In this view the line is not running yet.

NOTE: Line Speed is indicated in the bottom right-hand corner of the screen and must be > 0.1 FPM in order to operate.

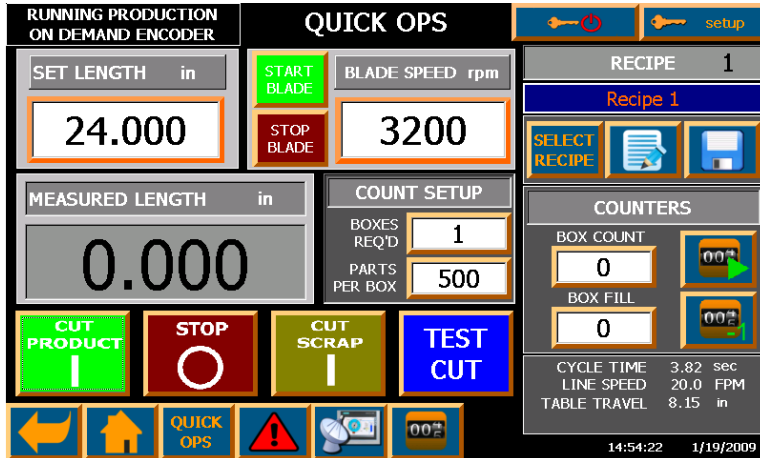

Example: system is running and cutting product. The red Stop button has dimmed, and the green Cut Product button has lit. The status box in the top left-hand corner has changed to indicate that the machine is now running and using an encoder.

The status area in the bottom right-hand corner status shows the last cycle time, line speed and the distance that the table traveled.

Each cutter is pre-programmed via the SETUP screens.

10.1 Quick Ops Buttons

10.1.1 Cut Parameter – is used to enter the cut interval. The actual parameter shown depends on the cut mode.

Example: Encoder mode uses Set Length. Set Length is shown whether the machine is running or stopped.

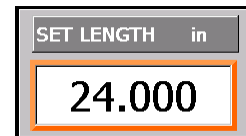

Cut Mode	Parameter	Units
Encoder	Set Length	in / mm
End Sense	Delay Time	sec
Timer	Cycle Time	sec

10.1.2 Blade Controls – are used to start and stop the blade and to set blade speed rpm.



10.1.3 Measured Length - shows actual length.

Options are to latch the last cut length or to hold the last cut length for a time before showing accumulated length. When an encoder is not used this parameter will remain zero.

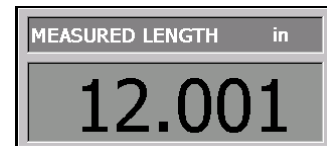

10.1.4 Control Buttons



Cut Product – is used to start cutting good product. If count is enabled, pieces will be counted.

Stop – is used to stop the cutter. If a cut cycle has already begun, it will continue running until the table has returned home.

Cut Scrap – is used to start cutting using the scrap settings. These pieces are not counted. Scrap can be used to change modes. The Cut Scrap button may be hidden from the operator – see System Setup.

Test Cut - causes a test cut. The test cut can be executed at any time. It is not counted. The method for executing a test cut can be set in two ways in the system setup – see System Setup.

10.1.5 Recipe Functions



Recipe Number - the grey field at the top shows the active recipe number.

Recipe Name - the blue field shows the active recipe name associated with recipe number. By default, recipe names are "Recipe" followed by recipe number. A level 2 operator can set a recipe from the Recipe Management page.



is used to access a preconfigured recipe. On power up, recall recipe is shown. This allows a quick recovery of a recipe after a power outage - see Recipe Select.



is used to edit the current recipe. Cut parameter, blade speed and count setup values are part of the recipe. Some items in a recipe can be changed by a level 1 operator, others require a level 2 operator. All parameters are visible - see Current Recipe.



is used to update the recipe. It is blue when active for level 2 and higher operators. This button will remain grey if no changes were made. Confirmation to save is required as current recipe will be overwritten.

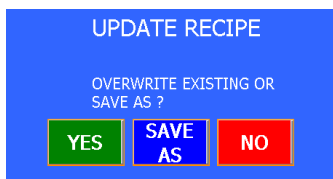

Update Recipe popup appears with options - Yes, No or Save As.

Special Manual / Default Recipe - a special recipe is available for when the operator wants to manually enter values without accidentally overwriting an existing recipe. This is known as the "Default" recipe. The recipe number for the default recipe is 0 and its name is "Manual". This recipe is factory set with known good starting values for a typical new product - see Recipe Select.

10.1.6 Count Setup

- is used to determine when a batch and / or a job has finished. The appearance of this section depends on the box count option.

Counts can be set up to activate functions, alarms, and outputs based on when a box or production run has finished.

If "Boxes Req'd" or "Pieces Req'd" is reset to 0, the production run will never provide a finished event.

"Parts Per Box" must always be greater than zero in order to function.

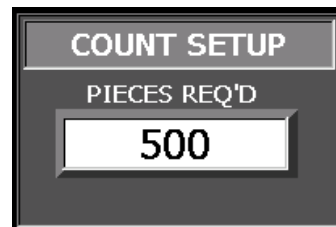
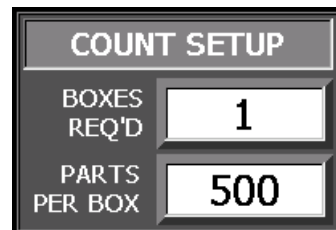

10.1.7 Counters

These parameters are for the batch counter. The choice will depend on whether box counting is required. Press a count value to change it. A keypad appears.

The button in the top-right corner is for pause or run.



The button in the bottom-right corner is used to remove one part from the count, for example operator notices a damaged part.

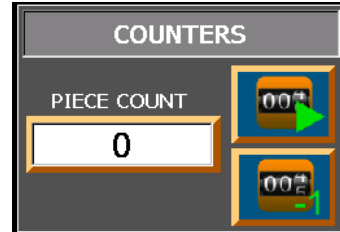
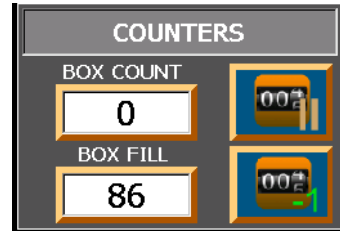

10.1.8 Batch Counter Setup - accesses batch count features - see Counters section.

10.1.9 Production

This status area displays useful information about the process.

CYCLE TIME measures how long it took to execute the entire cut cycle from leaving to returning to the home position.

CYCLE TIME	3.82	sec
LINE SPEED	20.0	FPM
TABLE TRAVEL	8.15	in



LINE SPEED is the calculated line speed – typically based on encoder scale.

TABLE TRAVEL indicates the forward travel that the table used on the last cut (maximum forward travel is 21 inches).

11.0 RECIPE SCREENS

11.1 Current Recipe



is used to access Current Recipe. Product and Scrap have the same options, which can be set different from one another.

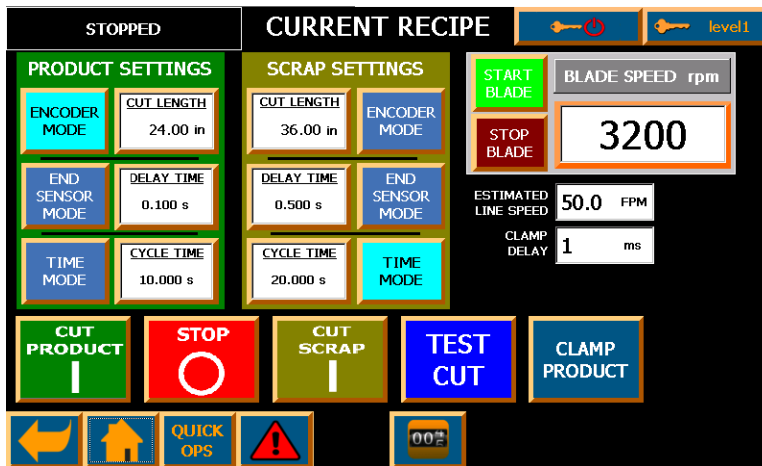

Encoder Mode – sets a mode based on a measured length interval. Length is typically provided by an encoder mounted on an upstream Puller. Other methods are available.

Cut Length – is used to set the part length when in Encoder Mode.

End Sensor Mode – is used to trigger a cut from a sensor input.

Delay Time – Set the time in seconds after the end sensor activates before the cut is activated. 0.000 s causes the cut to occur instantly.

Time Mode – sets a mode based on a time interval.

Cycle Time – sets the time interval.

Blade Controls – this section is used to start and stop the blade and to set the blade speed. Blade speed can affect cut quality.

Estimated Line Speed – calculates line speed from an encoder source. This can be set manually when not using an encoder. Speed can also be via a Profinet source, for example from upstream Puller.

Clamp Delay - is used to delay the saw activation.

11.2 Recipe Select

Recipe #	Recipe Select Material ID	Material Name	
1	0	Recipe 1	
2	0	Recipe 2	LOAD DEFAULT VALUES
3	0	Recipe 3	
4	0	Recipe 4	
5	0	Recipe 5	
6	0	Recipe 6	
7	0	Recipe 7	
8	0	Recipe 8	
9	0	Recipe 9	
10	0	Recipe 10	



Up and Down arrows are used to navigate to the required recipe. Arrows with '10' in them provide navigation one page at a time. Recipe 1 requires that the down button be pressed once followed by the up button.



is used to activate the highlighted recipe. Example: Recipe 2 is highlighted above so will be loaded.



An alternative option is to use "Load Default Values" – this activates the manual recipe.

Recipe Save As



is available to save a recipe. The Recipe Save As screen is the same as the Recipe Select screen except that the LOAD DEFAULT VALUES option is replaced by the check box. Select the recipe where to save, then press the check box button.

12.0 COUNTERS

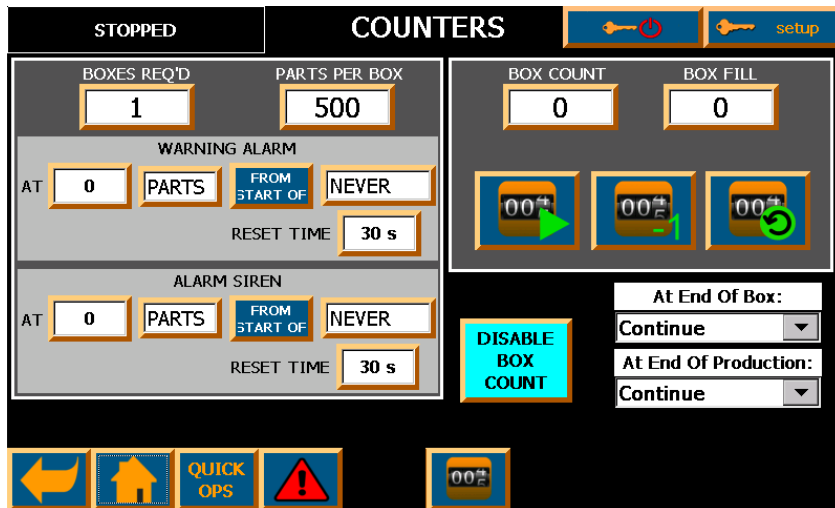

Many presets here are duplicates to those available in the Quick Ops section. The following explains the extra options not in Quick Ops.



Press and hold to reset counters.

Alarms

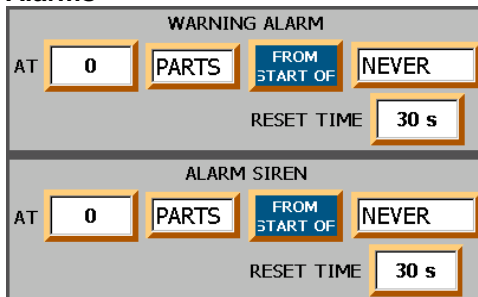

Options are available to activate a warning message or sound a siren when a production reaches a certain count.

Enter the time or number of parts required to activate the event – using the “At” preset.

The second preset sets whether the event will activate by part count or by time in seconds or minutes.

The third preset sets whether the count will be from the start or the end of a selected event.

The fourth preset can be set to Never, End of Box, End of Production, or Both.

The Warning Alarm activates a warning message. The Alarm Siren activates the horn, which can be silenced in the Quick Ops section. The siren must be configured in System Setup. Enter how long this alarm should remain activate in the Reset Time field. A setting of zero will latch the event until the operator acknowledges it or the condition is no longer present.

At End of Box: - is used to determine the action of the saw when the part count reaches the end of box. End of Box requires box count to be enabled.

At End of Production: – is used to determine the action of the saw when the part count has reached the total pieces setting.

- **Continue** – the saw keeps cutting the same product and counter continues to increment.
- **Cut Scrap** – if scrap mode is enabled, the saw will now execute the scrap recipe and the piece counter will stop.
- **Stop** – stops the saw.

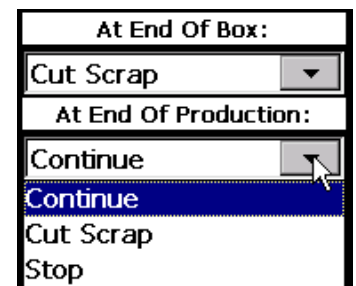

Box Count – is a toggle action switch used to enable or disable box counting method. Box count is enabled when the button is lit.

13.0 SETUP SCREENS

13.1 SETUP 1

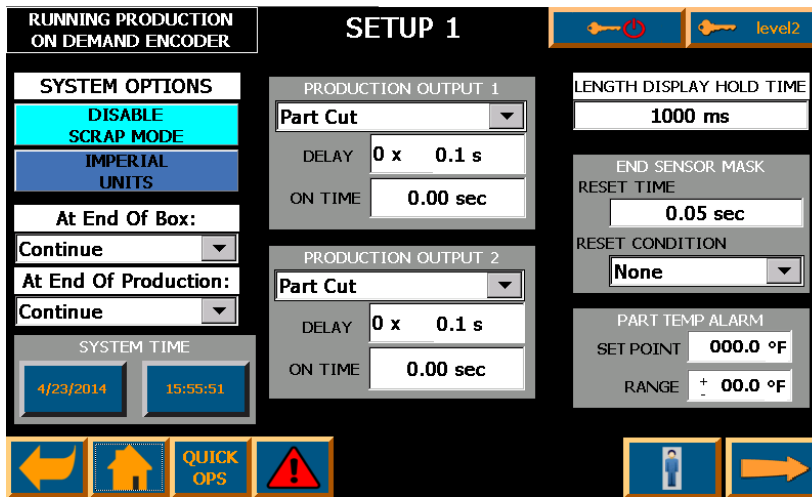

Level 2 or higher is required to access.

The arrow to go to the second setup page will appear for users with level 3 or higher.

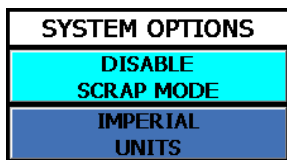

Enable / Disable Scrap Mode – has a toggle action. Scrap Mode is enabled when lit.

Imperial / Metric Units – has a toggle action to select units between English in inches or Metric in millimeters.

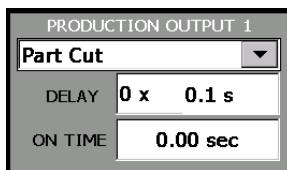

Production Outputs - two dry contact outputs are provided at the PLC - DQ8 relay extension module (page 7 of schematics – econn18 M12 F 5-pin is available for remote quick connect). An optional Analog output is available.

Production Output 1 = Q8.0
Production Output 2 = Q8.1

Each output can be configured to trigger on many events including Part Cut, Box Change, Production Done, Running, Run Product, Run Scrap, Stopped or Faulted. These signals can be delayed and held using the time settings. These outputs are low priority with a typical latency of about 30 ±10 msec.



this setting determines how long the display will hold the last cut before showing the next accumulated length. Set to zero to only show the last cut length.

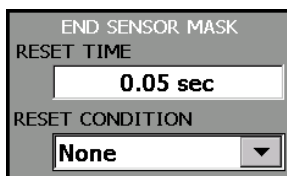

this setting is similar to a filter or anti-bounce and is used to prevent unwanted triggers from the sensor input. Reset time acts like an ignore period. A good rule of thumb is to set this to 75% of the expected time between cuts so that it is ready just before the next trigger. This mask can be configured to use the positive or negative signal edge. End Sense is on PLC Input 0.3 (page 4 of schematics – econn17 M12 F 5-pin is available for remote quick connect).



User Configuration Access - selects the User Configuration screen.



use to set system date and time.

13.2 SETUP 2

Set up 2 is available for level 3 and higher users.

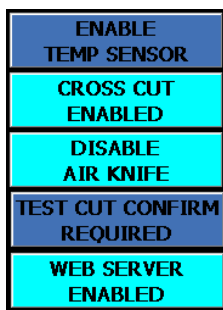
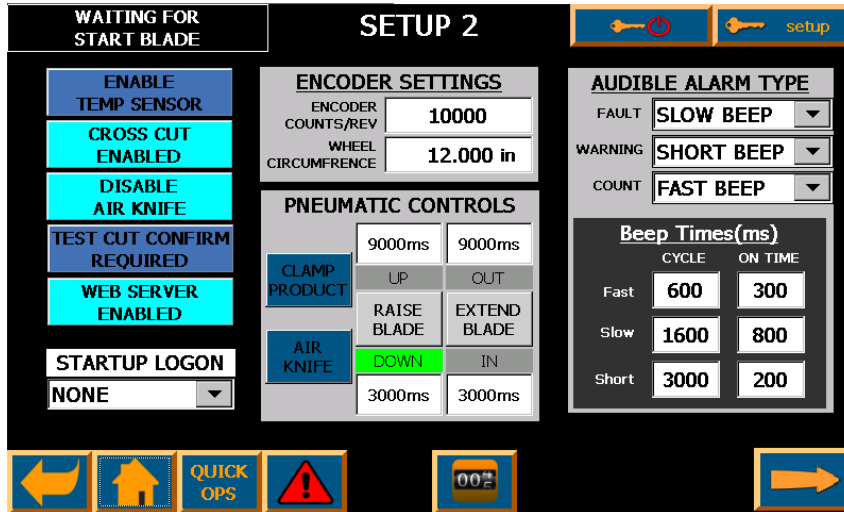

Temperature Sensor – currently unavailable on saws.

Cross Cut – for cross-cut saws.

Air Knife - for air knife option.

Test Cut Confirm Required – option for popup window to confirm a test cut.

Web Server – for access by another HMI or web browser. A license is required - a message will appear every few minutes if the license is missing and access will be blocked.



All machines ship with user login set to NONE. This means an operator must log in to start the machine. The saw can be fixed to start up at level 1, 2 or 3.

NOTE: Be wary of using a higher than needed setting as this will give operators access to areas which they do not need.

Encoder Scale

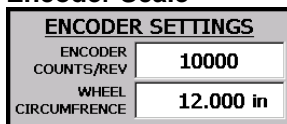

Counts per Revolution – this sets the number of quadrature counts per revolution of the encoder. Example: A 5,000-ppr Quadrature Encoder, using the method known as Quadrature x 4 provides 20,000 counts per revolution. Quadrature Encoders use two inputs known as channel A and channel B.

Wheel Circumference – this is the linear distance for one turn of the encoder measure wheel. If an encoder is attached to a pulley drive shaft use the pulley diameter x pi.

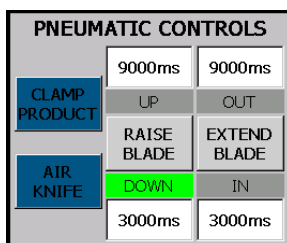

Pneumatic Controls – this area is available for manual test of the pneumatics. Air Knife and Extend Blade options are included when installed.

Buttons appear red when active.

Sensors may be used and they will light up green when on.

Timers are available to set duration of each activity.

AUDIBLE ALARM TYPE		
FAULT	SLOW BEEP	
WARNING	SHORT BEEP	
COUNT	FAST BEEP	
Beep Times(ms)		
	CYCLE	ON TIME
Fast	600	300
Slow	1600	800
Short	3000	200

Audible Alarm Type - is used to configure the horn sounds. Different sounds can be set for Fault, Warning, and Count complete.

Alarm choices are None, Slow Beep, Short Beep, Fast Beep, and Continuous. Each beep duration and frequency (cycle time) can be customized.

13.3 SETUP 3

Set up 3 is available for level 3 and higher users

The screenshot shows the 'SETUP 3' interface with the following sections:

- SYSTEM LIMITS:** MIN BLADE SPEED (2275 RPM), MAX BLADE SPEED (3200 RPM), MAX CUT RATE (15 CPM), MAX LINE SPEED (50 FPM).
- VELOCITY ADJUSTMENTS:** OFFSET (0.00 FPM), SCALE (+1.0000), GAIN (0.99), MEASUREMENT WINDOW (+100.0%).
- SPEED MATCHING CALC:** (Empty fields)
- BACKGROUND:** Three vertical bars with values 255, 255, 255 and corresponding colored buttons (red, green, blue) with '0' below them.
- LENGTH REF SOURCE:** Estimated Line Speed (dropdown)
- SPEED REF SOURCE:** Estimated Line Speed (dropdown)
- Buttons:** SERVO SETUP, EXIT HMI, RESET SYSTEM TO FACTORY DEFAULTS.
- Navigation:** Home, QUICK OPS, and other control icons.

SYSTEM LIMITS	
MIN BLADE SPEED	2275 RPM
MAX BLADE SPEED	3200 RPM
MAX CUT RATE	15 CPM
MAX LINE SPEED	50 FPM

System Limits – defines blade speed and cut-rate limits.

Min Blade Speed - sets the minimum blade speed that can be entered on the recipe screen.

Max Blade Speed - sets the maximum blade speed that can be entered.

Max Cut Rate – this determines the minimum time between cuts. Example: 15 CPM = 15 pieces may be cut per minute.

Max Line Speed – sets the maximum line speed allowed. This also sets the speed for the table to return to home.

LENGTH REF SOURCE	
Estimated Line Speed	(dropdown)
SPEED REF SOURCE	
Estimated Line Speed	(dropdown)

Length Reference Source– sets the source measuring method.

Speed Reference Source - has the same options as the length reference but is used for table speed.

Estimated Line Speed – provides a line speed simulator.

Encoder – uses the encoder counts for length and / or line speed.

Profinet – is for a communication connection between a NOVATEC supplied puller and saw. The puller transmits its actual speed as a telegram to the saw every tenth second.

VELOCITY ADJUSTMENTS	
OFFSET	0.00 FPM
SCALE	+1.0000
SPEED MATCHING CALC	
GAIN	0.90
MEASUREMENT WINDOW	+ 100.0 %

Velocity Adjustments – is for calibration of an input reference velocity.

- **Offset** – adds a signed value to the input reference.
- **Scale** – scales the input reference. This is a multiplier value.

Speed Matching Calc – is used to set response.

- **Gain** - determines how fast the cutter responds to changes in line speed. Setting 0.99 provides immediate reactions but can cause oscillation. A typical setting is between 0.5 and 0.8.
- **Measurement Window** – determines range. Three line speed readings outside the expected range window will cause the saw to stop. A setting of 100% overrides this check.

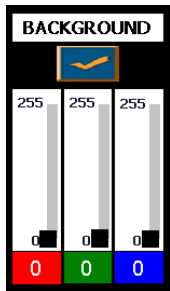

Screen Background Color - color mix - the Red, Green and Blue content for the background can be mixed by using these sliders. Alternatively, enter RGB values directly. The area around the check box shows the color mix result. When the color is as desired, use the checkbox to update the background color for all pages. Black (0,0,0) is the default background color.



CAUTION: Care should be taken when using very bright colors or colors that match other presets because this can cause a bleach out of some items.

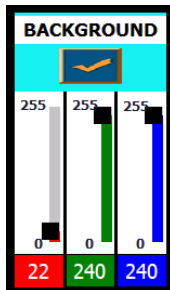

Example: RGB set to 22, 240, 240



this button will reset all setup values back to factory default. A drop-down box appears with the option to accept or cancel. **Use only if the setup values are altered such that the saw cannot run properly.**



SERVO SETUP - for maintenance and experienced operators. This provides a detailed setup information page for the cutter servomotor. This button is greyed out while the system is running.



EXIT HMI – is for maintenance personnel only. The operator interface program quits, and the Windows CE operating system begins. All control of the machine is lost until operator exits from Windows CE or machine is recycled.

13.4 Servo Setup Page

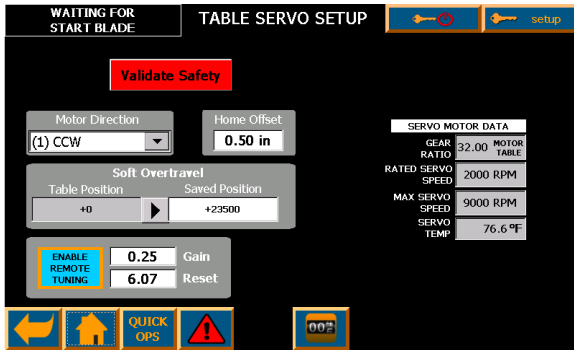

CAUTION: Care should be taken when accessing this page. Incorrect values set on this page by unqualified personnel could make the saw unusable

Validate Safety

Validate Safety - is used when commissioning the servo system or after a component is replaced. The procedure checks the components of the system against the stored safety program to ensure they match. Since components and software can be upgraded, this test must be performed even if the component being changed is the same type. The validation of components is required for the servo motor, encoder, power module, control unit, program, and compact flash (CF) card. The safety license is stored on the CF card. If missing, an alarm warning is shown but the system will still operate.



Motor Direction – the motor direction is set when the machine is first commissioned.



Home Offset – saws require a home reference. This is near the start end of the table. On initial startup the saw table moves to the home sensor. The table then moves forward to the Home Offset position and stops. This final position is the table home position (absolute zero). The home sensor now acts as a travel limit in case the table does not stop at home.

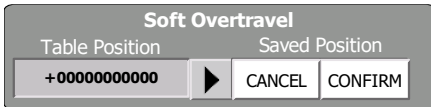

Soft Over-travel – provides a soft over-travel position of the table relative to the home position. Manually move the table to the desired position and press the arrow to save. A confirmation message appears in the numeric field.

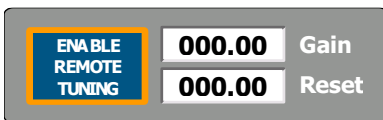

Remote tuning – is used to change tuning parameters for the table servo. These values can be adjusted to account for load and aging of the equipment.

WARNING - Improper settings could cause the servo to become unstable, or to lose torque or continuously fault. Remote tuning can be turned on or off.

Servo Motor Data– These values are for reference only and are dependent on the equipment installed.

SERVO MOTOR DATA		
GEAR RATIO	32.00	MOTOR TABLE
RATED SERVO SPEED	2000 RPM	
MAX SERVO SPEED	9000 RPM	
SERVO TEMP	76.6 °F	

Gear Ratio - Shows the gearbox / reducer ratio. Example: 32:1 gearbox.
Rated Servomotor Speed – is the rated speed of the motor @ the rated torque @ 400V - can be affected by ambient temperature and supply voltage.
Max Servomotor Speed – is the nameplate maximum speed of the motor.
Servomotor Temperature – actual temperature of the motor. *Most motors can handle temperatures up to 140°C (284°F).*
WARNING - Frequent heating and cooling of the motor can cause premature damage due to expansion and contraction.

14.0 MAINTENANCE

It is recommended that maintenance and inspection be performed on a scheduled basis. Maintenance requirements vary for each installation and operating condition. It is suggested that a complete inspection be performed with necessary maintenance at the end of the first month, first three months, and first six months. These inspections will indicate how often future maintenance might be necessary.

- All electrical, mechanical repairs and tests **MUST** be performed by qualified personnel.
- Disconnect electric power from the machine before accessing electrical enclosure.
- Depressurize pneumatic system before performing maintenance or repairs on pressure containing components.
- Do not disable or bypass equipment safety features.
- Refer to system component manuals for additional information.



WARNING: Before beginning repair work, disconnect all power sources (electric and pneumatic) and secure against inadvertent reconnection.



WARNING: Auxiliary equipment may contain moving parts that may cut, crush, or otherwise injure personnel if safety access covers are removed. Do not place hands or limbs in equipment during operation.

Installation

- Record equipment serial numbers and program revision level.

At Startup

- Verify all guards are in place and fully closed.
- Ensure hoses are attached securely.

Daily

- Clean debris from around the saw and inspect the cabinet for debris which would affect proper saw motion.

Weekly

- Use machine oil to flush / lubricate linear pillow block bearings. For heavy use do this twice per week.
- Inspect belt tension - if necessary lower upstream pulley and adjust to a point where the belt does not skip teeth at fastest speeds.

Every 3 Months

- Check all electrical connections to make sure that they have not become loose, especially connections at contactors (motor starters).
- Check all air lines to make sure they have not become loose.
- Lube the NS-6 saw cylinder guide bearings with sae 10w general purpose oil
- Use grease gun to lubricate the saw arm pivot bearings.

15.0 WARRANTY NOVATEC, INC. - EFFECTIVE DATE 8 MAY 2017

NOVATEC, INC. offers COMPREHENSIVE PRODUCT WARRANTIES on all of our plastic's auxiliary equipment. We warrant each NOVATEC manufactured product to be free from defects in materials and workmanship, under normal use and service for the periods listed under "**Warranty Periods**". The obligation of Novatec, under this warranty, is limited to repairing or furnishing, without charge, a similar part to replace any part which fails under normal use due to a material or workmanship defect, within its respective warranty period. It is the purchaser's responsibility to provide Novatec with immediate written notice of any such suspected defect. Warranted replacement parts are billed and shipped freight pre-paid. The purchaser must return the suspect defective part, freight prepaid and with identifying documentation to receive full credit for the part returned. Novatec shall not be held liable for damages or delay caused by defects. No allowance will be made for repairs or alterations without the written consent or approval of Novatec.

The provisions in equipment specifications are descriptive, unless expressly stated as warranties. The liability of Novatec to the purchaser, except as to title, arising out of the supplying of the said equipment, or its use, whether based upon warranty, contract, or negligence, shall not in any case exceed the cost of correcting defects in the equipment as herein provided. All such liability shall terminate upon the expiration of said warranty periods. Novatec shall not in any event be held liable for any special, indirect, or consequential damages. Commodities not manufactured by Novatec are warranted and guaranteed to Novatec by the original manufacturer and then only to the extent that Novatec is able to enforce such warranty or guaranty. Novatec, Inc. has not authorized anyone to make any warranty or representation other than the warranty contained here. Non-payment of invoice beyond 90 days will invalidate the warranty. A renewed warranty can be purchased directly from Novatec.

Please note that we always strive to satisfy our customers in whatever manner is deemed most expedient to overcome any issues in connection with our equipment.

Warranty Periods:

Note: All warranty periods commence with the shipment of the equipment to the customer.

5-Year

Resin Drying to Include

NovaWheel™ Dryers *
Dual Bed Dryers
NovaDrier *
NDM-5 Membrane Dryer
Gas-Fired Process Heaters
Gas-Fired Regeneration Heaters
Drying Hoppers
Central Drying Hopper Assemblies
Heater/Blower Units and Hot-Air Dryer
Silo Dehumidifiers
NovaVac Dryers *

Resin Blending and Feeding to Include

WSB Blenders, MaxiBatch & Feeders *
Gaylord Sweeper Systems

Resin Conveying to Include

GSL Series Vacuum Loaders
GlassVu Loaders, Receivers and Hoppers

Downstream Extrusion Equipment to Include

C and NC Bessemer Series Cutters
NPS Bessemer Series Pullers
NPC Mini Puller/Cutter
All NS Series Servo Saws
All Cooling and Vacuum Tanks Manufactured by Novatec

3-Year

When a Prophecy data plan is activated for VPDB and SVP pumps with PumpSense™, Novatec automatically extends the warranty to 3 years. The data plan must be activated within 60 days after pump shipment and remain active through the warranty period to maintain extended warranty eligibility. The first 6-months of data plan usage is free from Novatec.

2-Year

Central System Controls to Include

FlexTouch™ Series Controls
FlexXpand™ Series Controls
OptiFlex™ Series Controls
PLC Communications Modules
Greenboard Communications Modules
LOGO! Mini PLC

Moisture Measurement Equipment to Include

MoistureMaster®

PET Resin Crystallizers

Resin Conveying and Systems Components to Include

VL/VLP Series Loaders
VRH, VR, VR-FL & VRP Series Receivers
Compressed Air Loaders
AL-B Barrel Loader
Cyclone Dust Collectors
Conveying System Accessories
Surge Bins
Valves and Accessories
Electronic Metal Separators
Quick Select Manifolds
Tilt Tables
Filter Dust Collectors
Drawer Magnets

1-Year

Resin Conveying System Components to Include

*VPDB Vacuum Positive Displacement Pumps
*SVP Vacuum Pumps
MVP Vacuum Pumps
UltraVac Vacuum Pumps
Vacuum Regenerative Blower Pumps
Velocity Control Valves

*See 3-Year Warranty above

Central System Controls to Include

MCS-600 Series Controls – (Distributed I/O)
MCS-400 Series Controls
CL Silo Manager

Infrared Drers

***Custom Equipment of any kind unless otherwise specified.
Railcar Unloading System***

Exclusions:

Routine maintenance/replacement parts are excluded from the warranty. These include, but are not limited to hoses, desiccant, filters, filter elements, wiper seals, gaskets, dew point sensors, infrared lamps, motors, internal solenoids, fuses and motor brushes. Use with abrasive materials will void the warranty of any standard product. Wear resistant options may be available to extend usable service life with abrasive materials. Novatec reserves the right to limit the warranty if the customer installs replacement parts that do not meet the specifications of the original parts supplied by Novatec.

***Specific Exclusions:**

1. NovaDrier warranty is void if coalescing filters are not replaced on a 6-month or yearly basis (per instruction manual) and / or membrane has been exposed to ozone.
2. NovaVac Dryer -The ability of the canisters to hold vacuum will be compromised if the vacuum seal edge is damaged.
from mishandling. We do not warranty canisters damaged from improper handling. We do, however, warranty the seals.
3. LOAD CELLS on our WSB's are covered by Novatec standard warranty as long as they have not been damaged from improper handling.
4. Desiccant Wheel Warranty will be void if the wheel has been exposed to plasticizer, dust, or other contaminants as a result of negligence on the part of the processor.

This warranty shall not apply to equipment:

1. Repaired or altered without written approval of NOVATEC unless such repair or alteration was, in our judgment, not responsible for the failure.
2. Which has been subject to misuse, negligence, accident, or incorrect wiring by others.
3. Warranty is void if processing rates exceed manufacturer-recommended levels or if damage is caused by ineffective power isolation and/or power spikes/sags or incorrect installation.

NOTE: All conditions and content of this warranty are subject to changes without notice.