



VPDB / VPD Vacuum Pumps

Smart Pumps with Optional Predictive Maintenance

VPDB and VPD pumps provide powerful vacuum to convey free-flowing pellets, powders and regrind in single and multi-receiver systems.

Each vacuum pump is lubricated, tuned to deliver optimum vacuum and shipped fully assembled. An industrial discharge silencer is included.

- › **Monitor, Diagnose and Prescribe Corrective Action with Optional PumpSense™**



- › **Optional Prophecy Sensorlytics™ App**

Monitors pump components and sends maintenance advice and actionable intelligence via text and email. The purchase of optional PumpSense hardware includes free access to the Prophecy Sensorlytics data plan for six months.

- › **Vacuum Breaker Valve and Clear Canister Safety Filter**

These standard components provide trouble-free operation and long pump life by minimizing pump starts and internal dust contamination.

- › **Rotary Lobe Blower, Belt Driven by a 3-Phase Motor**

Creates deep vacuum for high throughput and/or long distance conveying.

- › **Electronic Motor Overload Protection**

Phase loss detection, plus quicker trip speed versus thermal overload provides superior motor protection.



VPDB-10

- › **New! E-Z Oil Drain**

Easy-open valves simplify oil changes.

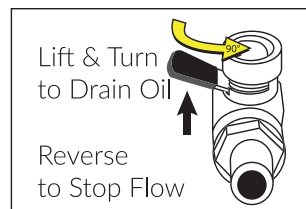

- › **Starter Panel Disconnect**

Circuit breaker provides local short circuit protection.

Plus

- › UL, CSA and CE compatible starter components
- › Fully enclosed belt housing
- › Vacuum gauge and relief valve
- › Standard pump voltage 460/3/60 (400V and 575V optional)
- › Standard control voltage 24 VDC (115V optional)
- › 3-year warranty
- › Extended 5-year pump warranty with activation and continued use of Prophecy Sensorlytics data plan.

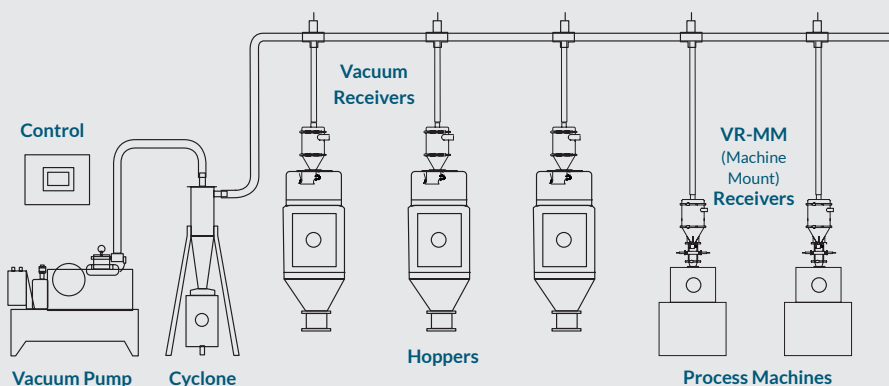

Specifications: (Consult factory for elevations above 3000 feet.)

Model Number	VPDB-3	VPDB-5	VPDB-7.5	VPDB-10	VPDB-10/3	VPDB-15	VPDB-20	VPD-25
Pump power	3 Hp	5 Hp	7.5 Hp	10 Hp	10 Hp	15 Hp	20 Hp	25 Hp
Inlet O.D.	1.5 in	2 in	2.5 in	2.5 in	3 in	3 in	4 in	4 in
Air volume	55 cfm	100 cfm	155 cfm	170 cfm	235 cfm	250 cfm	470 cfm	500 cfm
Vacuum relief	12 Hg	12.5 Hg	12.5 Hg	12.5 Hg	12.5 Hg	12.5 Hg	12.5 Hg	13 Hg
Width	42.6 in	42.6 in	44 in	44 in	44 in	56.5 in	52 in	71.17 in
Depth	30.6 in	30.6 in	30.6 in	30.6 in	33.8 in	37.2 in	39.3 in	35.33 in
Height	42.6 in	39.6 in	37 in	37 in	45.7 in	45.7 in	52.75 in	79.18 in
Product weight	480lb	515 lb	570 lb	575 lb	605 lb	750 lb	1015 lb	1360lb

Note: Height when stacked 2-high: 5 Hp= 86.4 in, 10 Hp= 83.7 in, 15 Hp= 104.6 in. Inquire about other models.
Standard control voltage: 24 VDC; Standard motor voltage 460/3/60

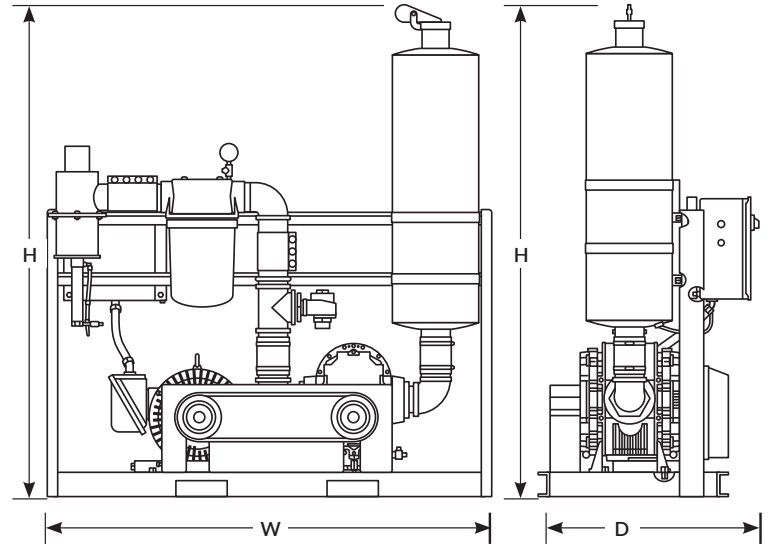
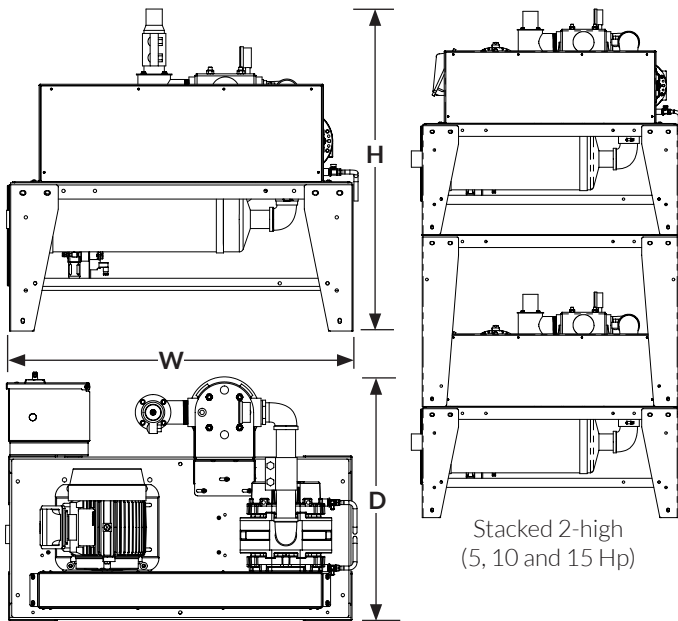

OPTIONS

- › **Alternate Control Voltages:** 115/1/60 VAC (no charge)
- › **Alternate Power Voltages:** 460/3/60 (standard)
575/3/60 (no charge) - includes fused disconnect with thermal motor overload protection
400/3/50 (no charge)
- › **DeviceNet Cable(s) for Pump:** In lieu of standard cable(s) (available in 24 VDC only)

ACCESSORIES

- › **Sound Curtain Kit:** 3-20 Hp



Optional sound curtain kit greatly reduces pump noise and allows easy access.

- › **DSV Discharge Selection Valve for Dry Air Conveying:**

EPV valve with connection stub to pump for 115 VAC or 24 VDC for line diameters of 1.5, 2, 2.5, 3 and 4 inches

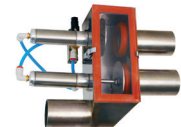

DSV discharge selection valve

- › **DeviceNet Cable for DSV:** (in lieu of standard cables - 24 VDC only)

- › **CLR Closed Loop Valve with Relief Vent:**

Provides pressure relief in a closed loop conveying system for line diameters of 1.5, 2, 2.5 and 3 inches



CLR closed loop valve with relief vent