



XSL Series Loader

The XSL Series Loader is standard with brushed motor, pendant control and pivot access.

XSL Series loaders provide self-contained, vacuum transfer of plastic pellets and regrind over short distances using powerful single-phase vacuum motors.

› **Double Pivot Access**

Loader operates in upright position then pivots and locks in place for easy access.

› **Full-Featured, Standard Plug-In Pendant Control**

Full-featured control is mounted on the loader. A 12-foot cable (standard) puts control at your fingertips, so changing loader parameters is easy.

› **MicroBurst Keeps Filters Clean**

High intensity MicroBurst blowback air blasts the whole filter area to remove dust and fines, ensuring that the dump throat is clear for proper sealing.

› **SureSeal Flapper Valve Avoids Loading Failures**

Reliable SureSeal seal surfaces stay aligned and resist wear, while a MicroBurst air blast removes residual dust for a tight seal.



XSL-12



Plus

- › 115V/1ph/50-60 Hz operation
- › 12 ft (3.66 meters) length of flex hose, lance and hose clamps
- › Dual reinforced polyester disc filter media
- › All material contact points are non-ferrous
- › Dump valve with integrated demand level switch on standard models
- › Conveying rate up to 500 lb/hr
- › Five-year warranty

Full-featured Pendant Control

Puts Loader Parameter Changes, Alarms, and Acknowledgments at the Operator's Fingertips

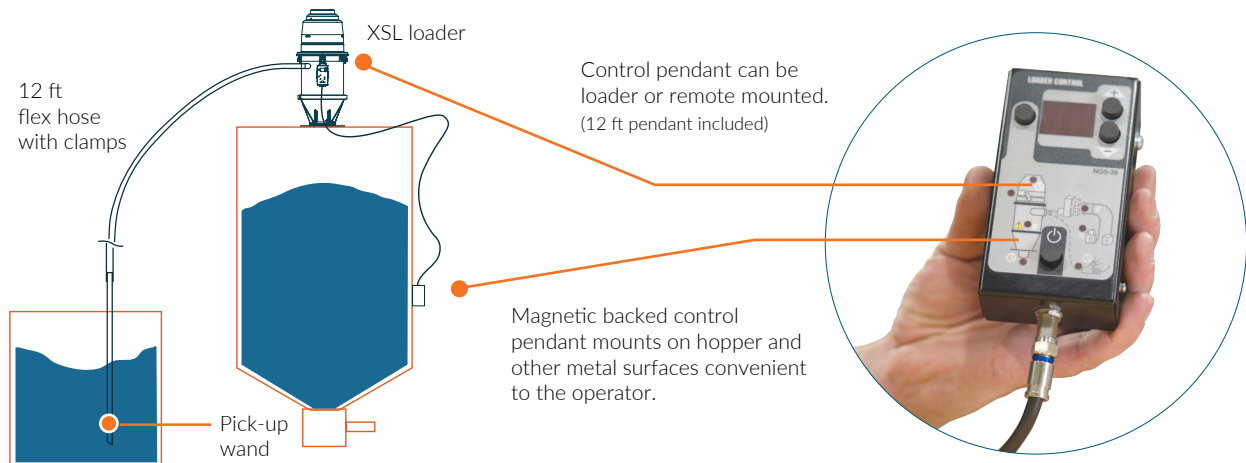

Full-featured control includes load time, no-load alarm, alarm light and silencer, as well as proportioning and purging.

Upright Operating Position



Pivot Position Clean Out is Quick and Easy



Easy pivot access for clean out.

Loader pivots forward from operating position and a captive detent pin locks loader in place during operation. Lid pivots back and locks in place for easy access.

Tool-less, Lockable Pivot Position Access



SPECIFICATIONS

XSL-12

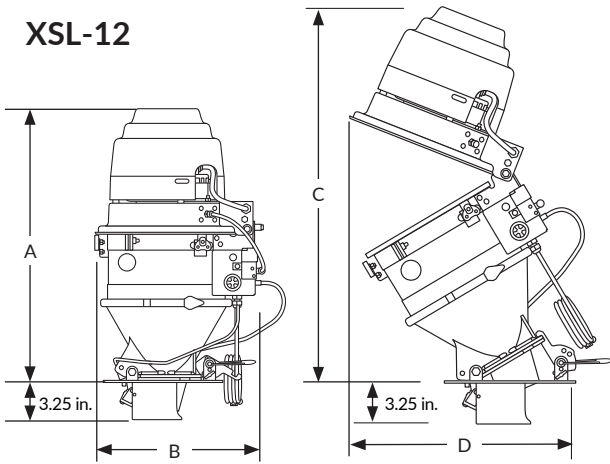

XSL-19

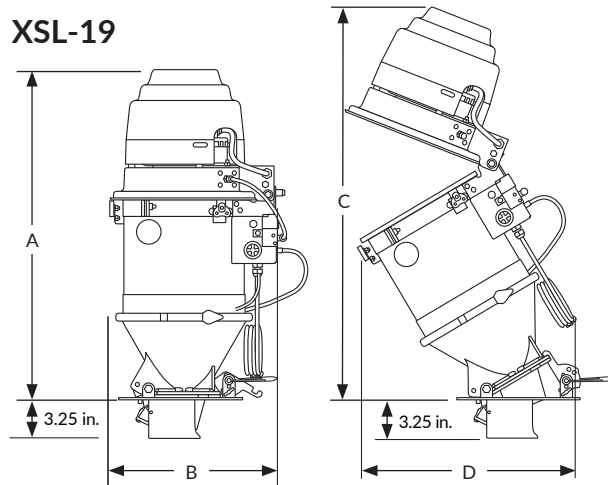

Model	Capacity*	Inlet O.D.	Discharge Diameter	A	B	C	D
XSL-12	12 lb	1.5 in.	3 in.	23.78 in.	14.83 in.	30.05 in.	17.52 in.
XSL-19	19 lb	1.5 in.	3 in.	27.78 in.	14.60 in.	33.46 in.	19.49 in.

*Based on PC pellets @ 38 lb/ft³

Pivoting and opening top requires 6 in. (15.2 cm) for clearance on XSL-19.

Recommended throughput: XSL-19 = up to 500 lb/hr (227 kg/hr) XSL-12 = up to 400 lb/hr (181 kg/hr) based on free flowing virgin pellets through 15 feet of flex hose.

Exceeding recommended throughputs may result in shortened motor and filter life; however, increased throughputs are possible depending on resin and equivalent feet calculation. Generally, a brushless GSL or central conveying system should be used for higher throughputs.

Maximum conveying distance in addition to 15 feet of hose, can include 30 feet of horizontal tubing and one elbow. Additional vertical travel, bends or flex hose will reduce recommended throughput.

Mounting Flexibility

Standard mounting hole pattern plus adapter ring allows XSL to replace any Novatec loader as well as competitive models.

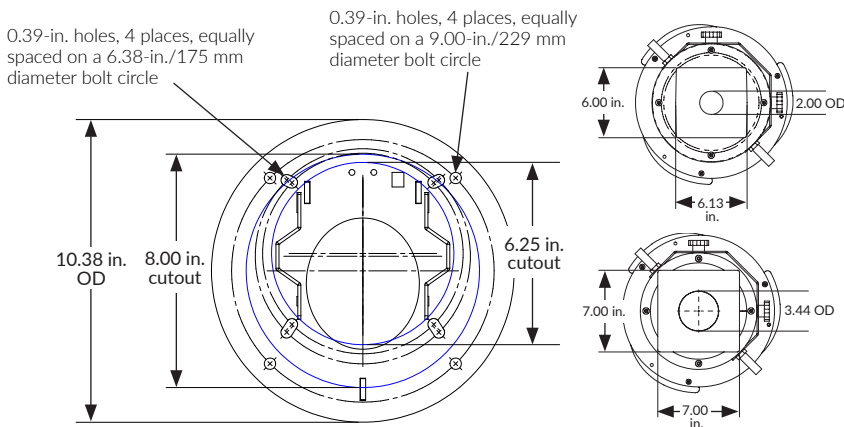

Mounting Patterns

Machine Mount Glass for GSLs/XSLs

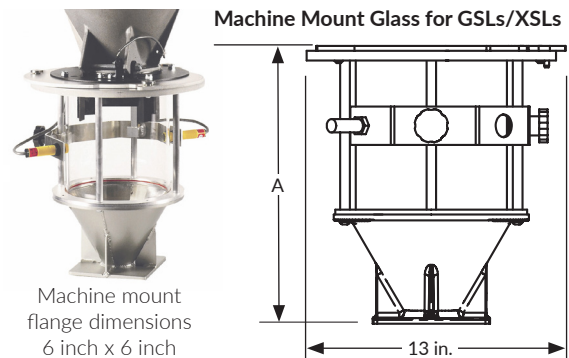

Config	Machine Mount Assy P/N*	A (in.)
8 lb	GMM-NGS-8	14.47
12 lb	GMM-NGS-12	18.47
16 lb	GMM-NGS-16	22.47

* Order separately. Must be assembled in field.

OPTIONS

- › **2-inch Inlet**
In lieu of the standard 1.5-inch inlet.
- › **Extended Wear Package**
Recommended when loading abrasive materials - contact factory.
- › **Alternate Glass Size**
12 lb glass (adds 4 in to height) or 16 lb glass (adds 7 in. to height).
- › **Retrofit Kit to Convert XSLs Into Machine-Mount Models**
Kit includes glass, twist-lock plug and photo-eye alternate mounting flange (7 in. x 7 in. with 3.5 in. opening) removes 1.5 in. from height.

ACCESSORIES

- › **Replacement Plug-N-Play Control Pendant with 12 ft Cable**
One included with each XSL.
- › **Replacement 12 ft Cable**
- › **External Proportioning Valve**
Includes coupler, wand, hose and clamps. 1.5 in. and 2.0 in. O.D.
- › **Level Switch, Capacitance, 30 mm dia., 2 m Cable**
- › **Capacitance Level Switch in Lieu of Photo-Eye Sensor**
For XSL-MM models.