



Railcar Unloading Systems

3
YEAR
warranty

Railcar unloaders are an integral part of high volume material delivery and storage solutions. These units transfer resin received in rail cars quickly and efficiently to on-site storage silos.

These powerful dual blower 'vacuum / pressure' systems are designed to move large volumes of free flowing plastic resin, as much as 10,000 to 30,000 lb/hr depending on model and transfer distances. Mix and match blower units with cyclone and airlock arrangements to accommodate a wide variety of applications and budgets.



Complete Package, Skid-Mounted

Simply supply power, terminate cyclone airlock & level sensor with provided cables, and wire your silo high level indicator(s) to the unit and its ready for operation.

Reduce Resin Clean Out and Silo Selection Mistakes

Available options allow unloading through 1 of 2 cyclone / airlock assemblies to as many as 12 silos. Auto-ID Proofing control is available to verify hose connections before filling begins.

Continuous Automatic Operation

Make hose connections to rail car and target silo, select that silo at the control panel, and press start... unit will automatically shut down when silo high level sensor is reached.

Automatic Dust Collection

Efficient Novatec-designed cyclone separates the majority of dust, fines and angel hair from incoming material.

Range of Pump and Line Sizes

25-40 Hp pumps and 4"- 6" line sizes.

Better Than Single Vacuum Pump Systems

Dual motor and blower systems deliver maximum pellet transfer rate for any tube size. They also deliver lower temperature pressure conveying air than single blower vacuum pressure systems, which reduces fines and angel hair for temperature sensitive pellets. Air cooling heat exchangers are also available for pressure conveying at even lower air temperatures.

Plus

- > NEMA 4 controls with disconnect.
- > Water resistant Polane painted weather shelter recommended for outdoor installations.
- > 3-Year warranty

Specifications:

RCU Model Dual Blower/ Motor	Rail car Unloader Vacuum/Pressure	Inlet/Outlet	Length	Width	Height
RCU-4D4D-2525	25/25 Hp	4" O.D. Tube	117"	46"	103"
RCU-4P4 P-2525	25/25 Hp	4" Pipe (4.5" O.D.)	117"	46"	103"
RCU-5D5D-4040	40/40 Hp	5" O.D. Tube	128"	50"	138"
RCU-6D6D-4040	40/40 Hp	6" O.D. Tube	128"	50"	138"

RCC Model	Airlock Size	Pipe Diameter Inlet/Outlet	Throughput	Length	Width	Height
RCC12-XXXX*	12"	4"/4"	up to 18,000 pph**	60	60	130
RCC14-XXXX*	14"	5"/5"	up to 25,000 pph**	60	60	130
RC16-XXXX*	16"	6"/6"	up to 32,000 pph**	60	60	142

* -XXXX must match RCU . (i.e. -4D4D or -4P4P etc.)

** Pounds per hour of free flowing pellets. Flake models also available.

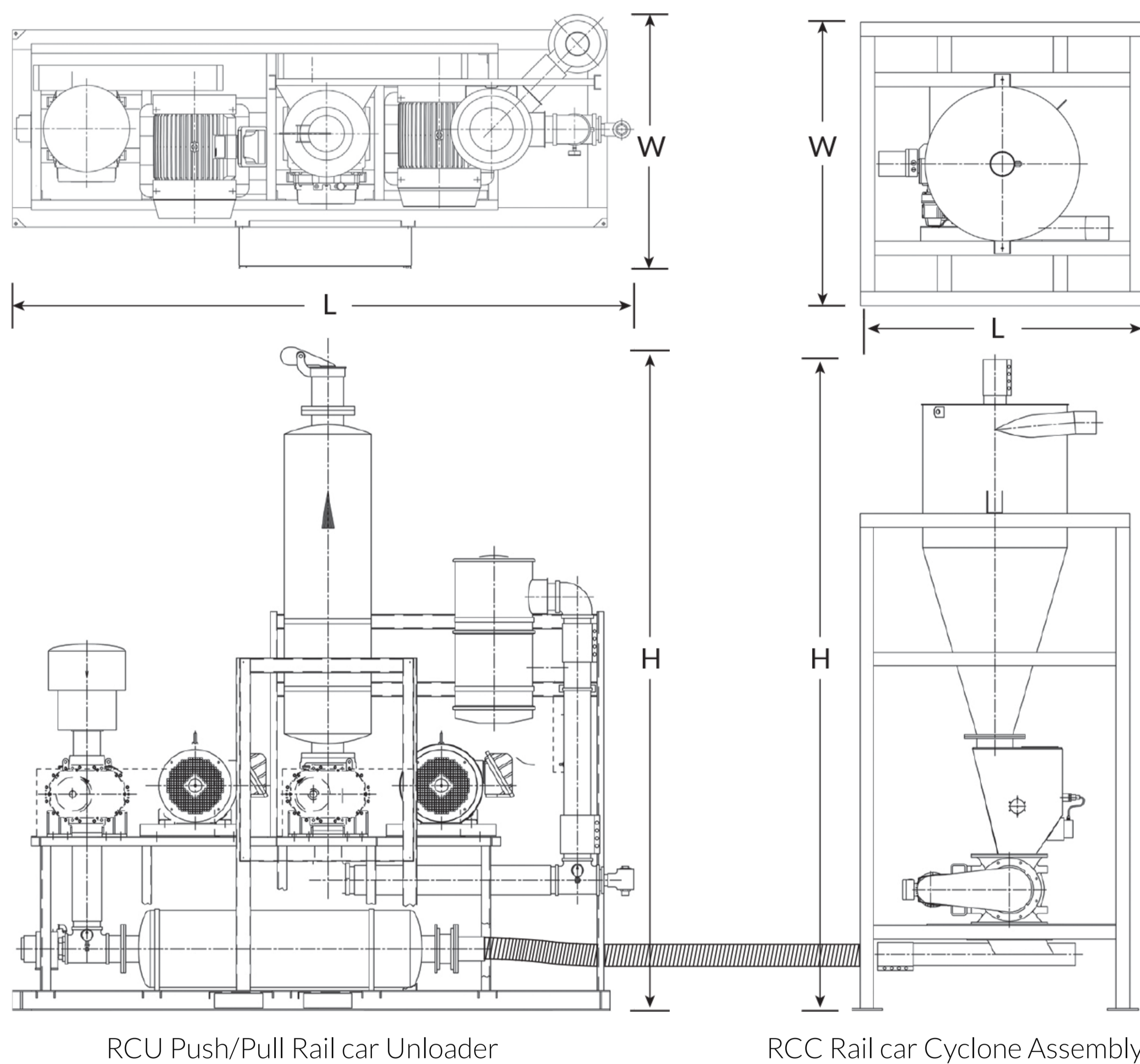

RCU Push/Pull Rail car Unloader

RCC Rail car Cyclone Assembly

Options:

Auto-ID proofing for silo selection

Control option for second RCC to segregate dissimilar materials

Chain Guide: #50 Chain (5 ft lengths)

Accessories:

Air-to-Air Heat Exchanger Models

In-line Angel Hair Traps (pressure and vacuum models)

Rail car Material Conveying Probe

Interconnecting Tubing, Bends and Couplers

SS Flex Hose for material connections

High Temperature Pressure Hose (connect RCU to RCC take-off tube)

Air-to-Air Heat Exchanger

Model	W	D	H
HE-AA-450	38.5"	31"	36.25"
HE-AA-650	51.5"	33"	36.25"
HE-AA-1000	66.5"	35"	37.75"

3 configurations available:

- Right in, left out
- Left in, right out
- U-flow

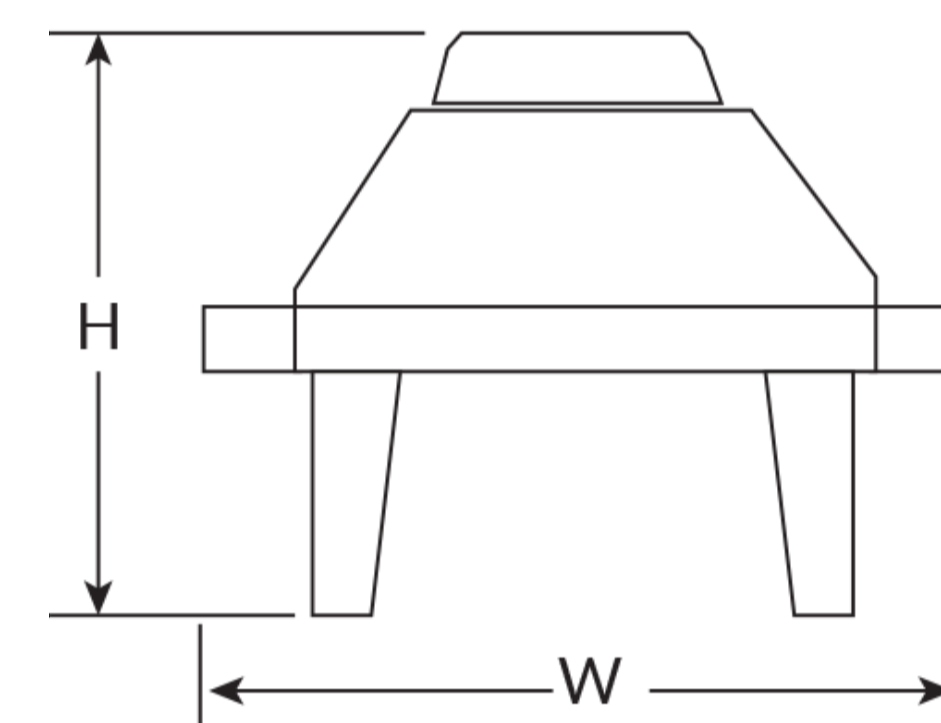
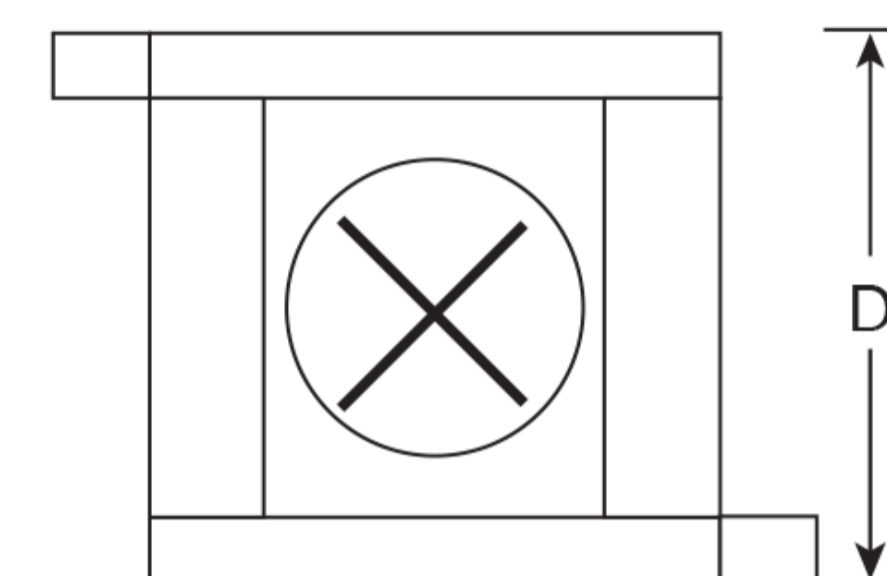

In-line Angel Hair Trap



Model	Line O.D.	Body O.D.	Body Height
AHT-ILP-40 AHT-ILV-40	4"	16"	9.9"
AHT-ILP-50 AHT-ILV-50	5"	16"	9"
AHT-ILP-60 AHT-ILV-60	6"	23.5"	14.4"